

# ABBREVIATIONS

@	AT	HC	HANDICAP, HOLLOW CORE, DR
#	NUMBER	HD	HOSE CABINET
X < Y	"X" IS LESS THAN "Y"	HD	HEADER
A > B	"A" IS GREATER THAN "B"	HDWD	HARDWOOD
		HDWR	HARDWARE
		HT	HEIGHT
AB	ANCHOR BOLT	HM	HOLLOW METAL
A/C	AIR CONDITIONER	HP	HEAT PUMP
ACDUS	ACOUSTICAL	HRZ	HORIZONTAL
AD	AREA DRAIN	HR	HOUR
ADJ	ADJUSTIBLE OR ADJACENT		
AFF	ABOVE FINISHED FLOOR		
AL	ALUMINUM	ID	INSIDE DIAMETER
ANDD	ANDDIZED	INSUL	INSULATION
APPRDX	APPROXIMATE	INT	INTERIOR
ASF	ABOVE SUBFLOOR		
AS	ABOVE SLAB	JAN	JANITOR
AMSL	ABOVE MEAN SEA LEVEL	JT	JOINT OR JOINT TRENCH
BD	BOARD	L	LINEN CLOSET
BLDG	BUILDING	LAB	LABORATORY
BLK	BLOCK	LAM	LAMINATE
BLKG	BLOCKING	LAV	LAVATORY
BM	BEAM	LT	LIGHT
BDT	BOTTOM	LT WGT	LIGHT WEIGHT
BUR	BUILT-UP ROOF		
C	COMPACT CAR PARKING SPACE	M	MICROWAVE
CAB	CABINET	MAX	MAXIMUM
CB	CATCH BASIN	MC	MEDICINE CABINET
CER	CERAMIC	MECH	MECHANICAL
CFCI	CONTRACTOR FURNISHED, CONTRACTOR INSTALLED	MEMB	MEMBRANE
		MFR	MANUFACTURER
CFOI	CONTRACTOR FURNISHED, OWNER INSTALLED	MH	MANHOLE
		MIN	MINIMUM
CL	CENTERLINE OR CLOSET	MISC	MISCELLANEOUS
CLG	CEILING	MLDG	MULDING
CLKG	CAULKING	MO	MASONRY OPENING
CLR	CLEAR	MTD	MOUNTED
CMU	CONCRETE MASONRY UNIT	MTL	METAL
CO	CLEAN OUT	MUL	MULLION
COL	COLUMN		
CONC	CONCRETE	N	NORTH
CONT	CONTINUOUS	OV	OVER
CT	COOKTOP OR CERAMIC TILE	N/A	NOT APPLICABLE
		NA	NOT AVAILABLE
		NIC	NOT IN CONTRACT
		NOM	NOMINAL
		NR	NON-RATED
		NSF	NET SQUARE FEET
		NTS	NOT TO SCALE
D	DRYER	O	OVEN
DBL	DOUBLE	OA	OVERALL
DEPT	DEPARTMENT	OC	ON CENTER
DEG	DEGREES	OD	OUTSIDE DIAMETER OR OVERFLOW DRAIN
DH	DOOR HEADER		
DF	DRINKING FOUNTAIN OR DIAMETER	OF	OVERFLOW
DIA	DIAMENSION	OFCI	OWNER FURNISHED, CONTRACTOR INSTALLED
DIM	DIMENSION	OFDI	OWNER FURNISHED, OWNER INSTALLED
DISP	DISPENSER	OFF	OFFICE
DN	DOWN	OL	OCCUPANT LOAD
DD	DOUBLE OVEN	OLF	OCCUPANT LOAD FACTOR
DR	DOOR	OPG	OPENING
DS	DOWNSPOUT	OH	OVERHANG
DSP	DRY STAND PIPE	O/H	OVERHEAD
DW	DISHWASHER	OPP	OPPOSITE
DWG	DRAWING	OP	OPERABLE
DWR	DRAWER		
E	EXISTING	P	POLE OR PANTRY
EA	EACH	PB	PARTICLE BOARD
EJ	EXPANSION JOINT	PL	PLATE OR PROPERTY LINE
ELEC	ELECTRICAL	P LAM	PLYWOOD
ELEV	ELEVATION	PR	PAIR
EMER	EMERGENCY	PT	POINT, PRESSURE TREATED OR POST TENSIONED
ENCL	ENCLOSURE	PTD	PAPER TOWEL DISPENSER
ENG	ENGINEER	PTN	PARTITION
EP	ELECTRICAL PANELBOARD	PW	PLUMBING WALL
EQ	EQUAL		
EQP	EQUIPMENT	QT	QUARRY TILE
EWC	ELECTRIC WATER COOLER		
EXP	EXPANSION OR EXPOSED		
EXT	EXTERIOR		
		R	RISER OR REFRIGERATOR
		RAD	RADIUS
		RAG	RETURN AIR GRILLE
		RD	ROOF DRAIN
		REF	REFRIGERATOR
		R/F	REFRIGERATOR/FREEZER
		REINF	REINFORCEMENT
		REQ'D	REQUIRED
		RESIL	RESILIENT
		REV	REVISION
		RF	RESILIENT FLOORING
		RM	ROOM
		RO	ROUGH OPENING
		ROW	RIGHT-OF-WAY
		R.U.	REAR UNIT
		RWL	RAIN WATER LEADER
		S	SOUTH OR SHELF
		S & P	SHELF AND POLE
		SB	SLASH BLOCK
		SC	SOLID CORE
		SCD	SEE CIVIL DRAWINGS
		SCHED	SCHEDULE
		SD	SMOKE DETECTOR
		DR	DR SOAP DISPENSER
		SF	SQUARE FEET OR FOOT
		SH	SOAP HOLDER
		SHR	SHOWER
		SHT	SHEET
		SHTG	SHEATHING
		SIM	SIMILAR
		SL	SLIDING
		SND	SANITARY NAPKIN DISPENSER
		SUB	SUBCONTRACTOR
G	GAS		
GA	GAUGE		
GALV	GALVANIZED		
GC	GENERAL CONTRACTOR		
GD	GARBAGE DISPOSAL		
GL	GLASS		
GR	GRADE		
GSM	GALVANIZED SHEET METAL		
GYP BD	GYPNUM BOARD		

# NON-STRUCT. GEN. NOTES

1. PROVIDE NEW ILLUMINATED ADDRESS NUMERAL CLEARLY VISIBLE FROM THE RIGHT OF WAY. 4" MIN. HIGH W/ 1/2" WIDE MIN. STROKE. NUMERALS TO CONTRAST W/ BACKGROUND. PER MUNI CODE 15.00.060
2. PROVIDE 5/8" TYPE 'X' GYP. BD. AT ALL WALLS & CEILINGS AT GARAGE, INSIDE FACE (TUNNEL SOLUTION). R-13 INSULATION AT COMMON WALL & R-19 INSULATION AT GARAGE CEILING.
3. GAS LINE SIZING CALCULATIONS, IF ANY NEW WORK, TO BE A DEFERRED SUBMITTAL ITEM & TO BE REVIEWED & APPROVED PRIOR TO INSTALLATION.

# SYMBOLS

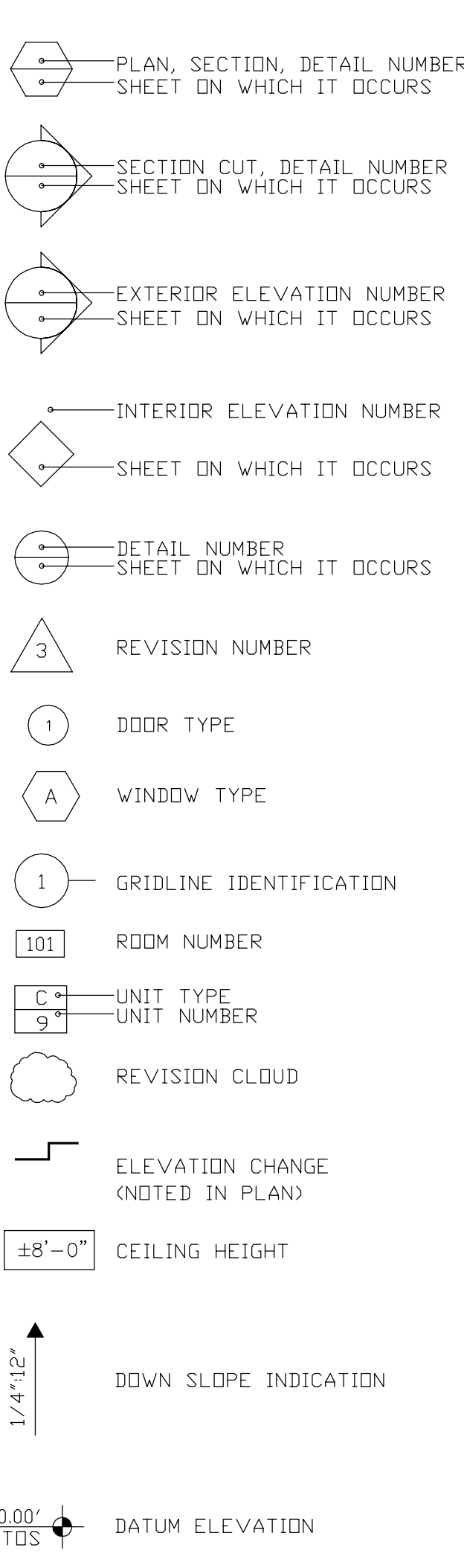

SH	SHOWERHEAD
SD	STORM DRAIN
SB	SETBACK
SDG	SLAB ON GRADE
SP	SUMP PUMP
SPEC	SPECIFICATION
SO	SQUARE
SSD	SEE STRUCTURAL DRAWINGS
SSD	SEE STRUCTURAL DRAWINGS
ST	STATIONARY
STL	STEEL
STDR	STORAGE
STRL	STRUCTURAL
SUBFLR	SUBFLOOR
SUSP	SUSPENDED
SYM	SYMMETRICAL
SW	SHEARWALL
SS	SANITARY SEWER
T	TILE, TREAD, TOP, OR TRANS DRIVER
T & G	TONGUE AND GROOVE
TB	TOWEL BAR
TBD	TO BE DETERMINED
TOC	TOP OF CURB
TDL	TRUE DIVIDED LITES
TEL	TELEPHONE
TER	TERRAZZO
TH	TOWNHOUSE
THK	THICK
THR	THRESHOLD
TD	TOP OF
TOP	TOP OF PLATE
TDS	TOP OF SUBFLOOR
TP	TOP OF PAVEMENT
TPD	TOILET PAPER DISPENSER
TRNS	TRANSPARENT
TV	TELEVISION
TOW	TOP OF WALL
TYP	TYPICAL
TPH	TOILET PAPER HOLDER
UDN	UNLESS OTHERWISE NOTED
VERT	VERTICAL
VEST	VESTIBULE
VIF	VERIFY IN FIELD
W	WEST, WASHER, OR WATER
W/	WITH
WC	WATER CLOSET
WD	WOOD
WH	WATER HEATER OR WINDOW HEADER
W X H	WIDTH BY HEIGHT
W/O	WITHOUT
WO	WHERE OCCURS
WP	WATERPROOF OR WORKING POINT
WR	WATER RESISTANT
WNDW	WINDOW
WSC	WAINSCOT
WSP	WET STAND PIPE
WT	WEIGHT
WWF	WELDED WIRE FABRIC

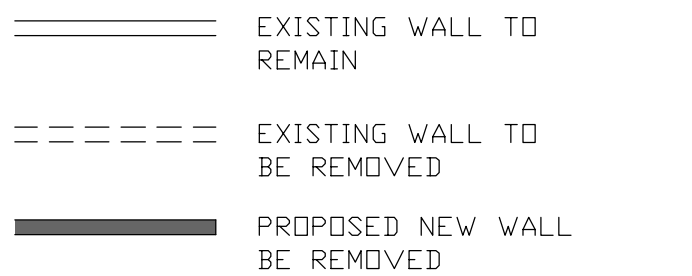

# PLANNING DATA

PROJECT COMMON ADDRESS:  
2367 RAINBOW COURT  
HAYWARD, CA  
APN: 0425-0410-026  
YR: 1981 (SUBDIVISION MAP FILING)

ZONING: RS, SINGLE FAMILY RESIDENTIAL ZONING DIST.  
LOT AREA = 12,078 SF (PER SURVEY)  
MAX. LOT COVERAGE = 40% X LOT = 4831 SF  
FRONT YARD SETBACK = 20 FT.  
REAR YARD SETBACK = 20 FT  
SIDE YARD SETBACKS = 10% LOT WIDTH @ FRONT SETBACK = 5 FT  
MAX. HT. = 30 FT, FINISHED OR EXISTING, WHICHEVER IS LOWER, TO MIDPT. PITCHED ROOF  
PARKING SPACES REQUIRED: 2 COVERED (PROVIDED)

PROPOSED AREAS:  
2-CAR GARAGE @ MAIN (STREET) LEVEL = 485 SF  
LOWER LEVEL = 1142 SF  
MAIN (STREET) LEVEL = 2083 SF (OPEN TO BELOW COUNTED)  
UPPER LEVEL = 887 SF

TOTAL CONDITIONED LIVING AREA = 4112 SF  
TOTAL RESIDENCE = 4597 SF

OTHER AREAS:  
REAR LOWER LEVEL DECK (OFF LOWER HALL) = 277 SF  
REAR MAIN LEVEL DECK = 227 SF  
UPPER LEVEL \*BEDROOM 10\* BALCONY = 90 SF  
UPPER LEVEL MASTER BEDROOM BALCONY = 90 SF

PROPOSED LOT COVERAGE = 2785 SF + 277 SF = 3062 SF < 4831 SF, OK

# MILESTONES

2/20/18 RESUBMITTAL - RESPONSES TO 9/18/17 COMMENT LETTER

# PROPERTY ADDRESS

AT FRONT OF BUILDING, PROVIDE AN ILLUMINATED ADDRESS W/ NUMERALS THAT ARE 4" HIGH MIN. & 1/2" THICK MIN. WIDE STROKE ON A CONTRASTING BACKGROUND.

# BUILDING CODE DATA

TYPE OF OCCUPANCY: R-3 / U  
CONSTRUCTION: TYPE V-B

ALL CONSTRUCTION SHALL CONFORM TO THE 2016 CALIFORNIA BUILDING CODE, 2016 CALIFORNIA RESIDENTIAL CODE, 2016 CALIFORNIA MECHANICAL CODE, 2016 CALIFORNIA PLUMBING CODE, 2016 CALIFORNIA FIRE CODE, 2016 CALIFORNIA ELECTRICAL CODE, 2016 CALIFORNIA ENERGY CODE, & 2016 CALIFORNIA GREEN BUILDING CODE.

# SCOPE OF WORK / PROJECT DESCRIPTION

NEW "HIGHEST & BEST USE" 3-LEVEL SINGLE FAMILY RESIDENCE W/ ATTACHED 2-CAR GARAGE, VACANT DOWNSLOPE, PIE-SHAPED LOT, 5 BEDROOMS, 5.5 BATHS, & OFFICE ALONG W/ VARIOUS EXTERIOR BALCONIES / DECKS.

# SCHOOL FEES

PER LOCAL SCHOOL DISTRICT(S) FOR PROJECTS 500 SF OF LIVING AREA

# "HERS"

-HERS TESTING & VERIFICATION TO BE PART OF THIS PROJECT  
-HERS TESTING & VERIFICATIONS REQUIRED FOR DUCT LEAKAGE & IAQ VENTILATION FAN COMPLYING W/ ENERGY CODE REQUIREMENTS AND INDICATED ON ENERGY FORMS.

-HVAC INSTALLERS SHALL BE TRAINED & CERTIFIED IN THE PROPER INSTALLATION OF HVAC SYSTEMS INCLUDING DUCTS & EQUIPMENT. UNCERTIFIED PERSONS MAY PERFORM HVAC INSTALLATIONS ONLY WHEN UNDER THE DIRECT SUPERVISION & RESPONSIBILITY OF A CERTIFIED INSTALLER OR LICENSED HVAC CONTRACTOR. VERIFICATION OF CERTIFICATION IS REQUIRED.

# SATELLITE VIEW



## PROJECT DIRECTORY

OWNERS	QUAN & THIP TRAN	T: 510.390.1580 (QUAN) T: 510.390.1579 (THIP)
SURVEYOR	CANUMAY LAND SURVEYING	PAUL CANUMAY T: -
CIVIL	LUK & ASSOCIATES	JACKIE LUK, LS EDUARDO QUIROZ, PD MANISH DALIA, PE T: 510.724.3388
LANDSCAPE	PEDERSEN ASSOCIATES	PETE PEDERSEN, PRINCIPLE TAEKD KAWASAKI, PD T: 415.456.2070
ARCHITECT	BAUKUNST	MARK BUCCIARELLI, AIA T: 650.755.1093 E: baukunst2000@yahoo.com www.baukunstarchitecture.com
STRUCTURAL ENGINEER	NY ENGINEERING	NILGUN WOLPE, PE T: 415.568.1270 E: nyengineering@sbcglobal.net
TITLE 24 (ENERGY)	NRG COMPLIANCE, INC	MARIO BETACCO RICK RODKLEWITZ T: 707.237.6597 E: title24report@gmail.com

# EXISTING CONDITIONS



**BAUKUNST**  
58 Fruitwain Avenue, Daly City, CA 94015  
T: 650.455.1207 F: 650.755.1093  
E: baukunst2000@yahoo.com W: baukunstarchitecture.com

**CUSTOM RESIDENCE**  
2367 RAINBOW CT.,  
HAYWARD, CA

DATE	ISSUED FOR
6/22/16	CD
	NO SCALE
<b>A0.0</b>	



BIRD'S-EYE VIEW



STREET VIEW

ISSUED FOR

DATE

**BAUKUNST**  
 58 Fairview Avenue, Daly City, CA 94015  
 T: 650.455.1207 F: 650.755.1093  
 E: baukunst2000@yahoo.com W: baukunstarchitecture.com

© Copyright 2005- Baukunst  
 This drawing is the sole property of the Architect and may not be reproduced or used without the written consent. The right to build only one structure at said project address from these plans is licensed exclusively to the specific project owner.

**CUSTOM RESIDENCE**  
 2367 RAINBOW CT.,  
 HAYWARD, CA

6/22/16	CD
-	NO SCALE

**A0.1**

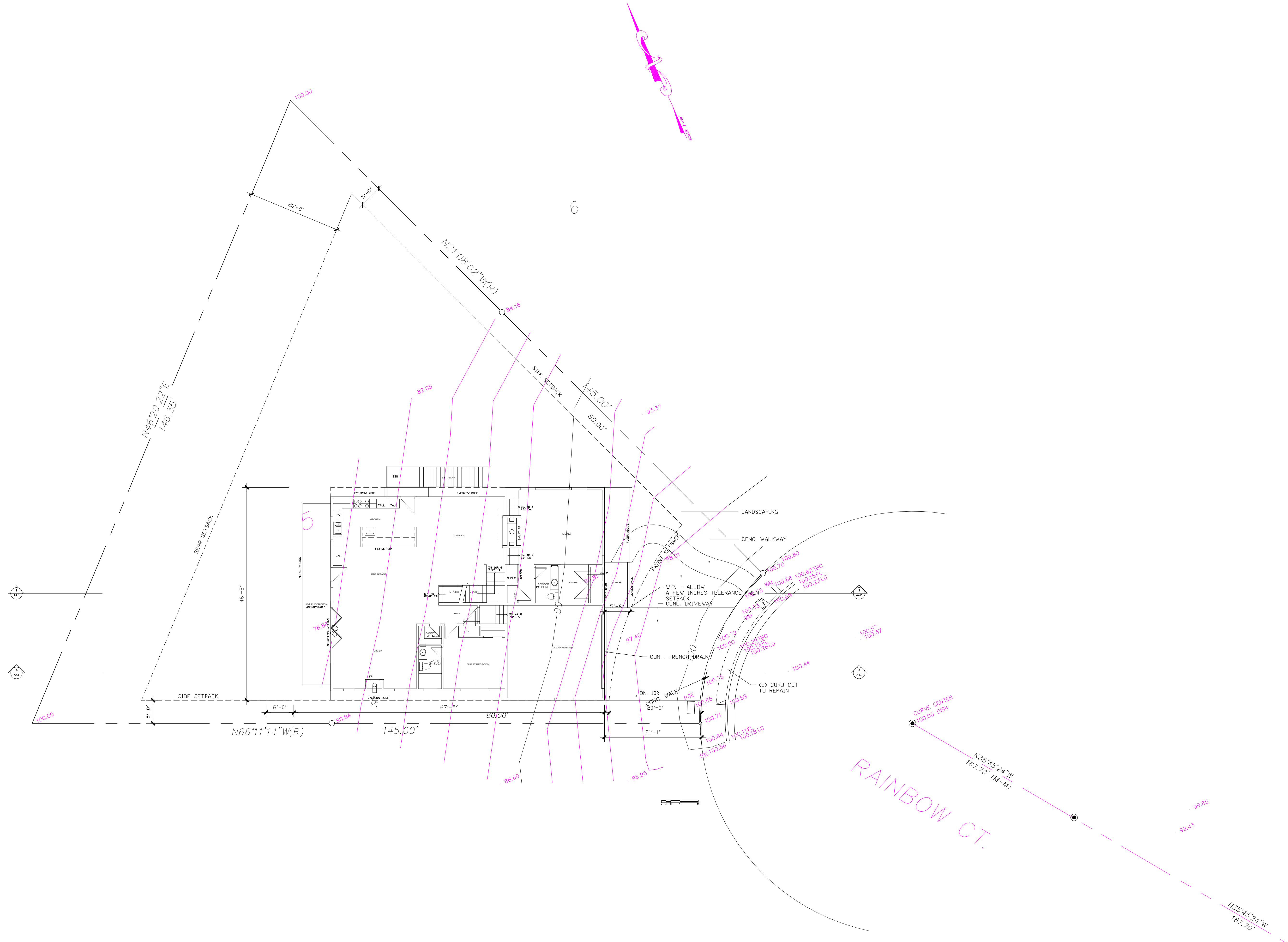

ARCHITECTURAL SITE PLAN (W/ SURVEY & SECTIONAL CUTS)

DATE

ISSUED FOR

**BAUKUNST**

58 Fairlawn Avenue, Daly City, CA 94015  
 T: 650.455.1207 F: 650.755.1093  
 E: baukunst2000@yahoo.com W: baukunstarchitecture.com

© Copyright 2005- Baukunst  
 This drawing is the sole property of the Architect and may not be reproduced or used without the written consent. The right to build only one structure at said project address from these plans is licensed exclusively to this specific project owner.

**CUSTOM RESIDENCE**  
 2367 RAINBOW CT.,  
 HAYWARD, CA

1"=10'

**A1.0**

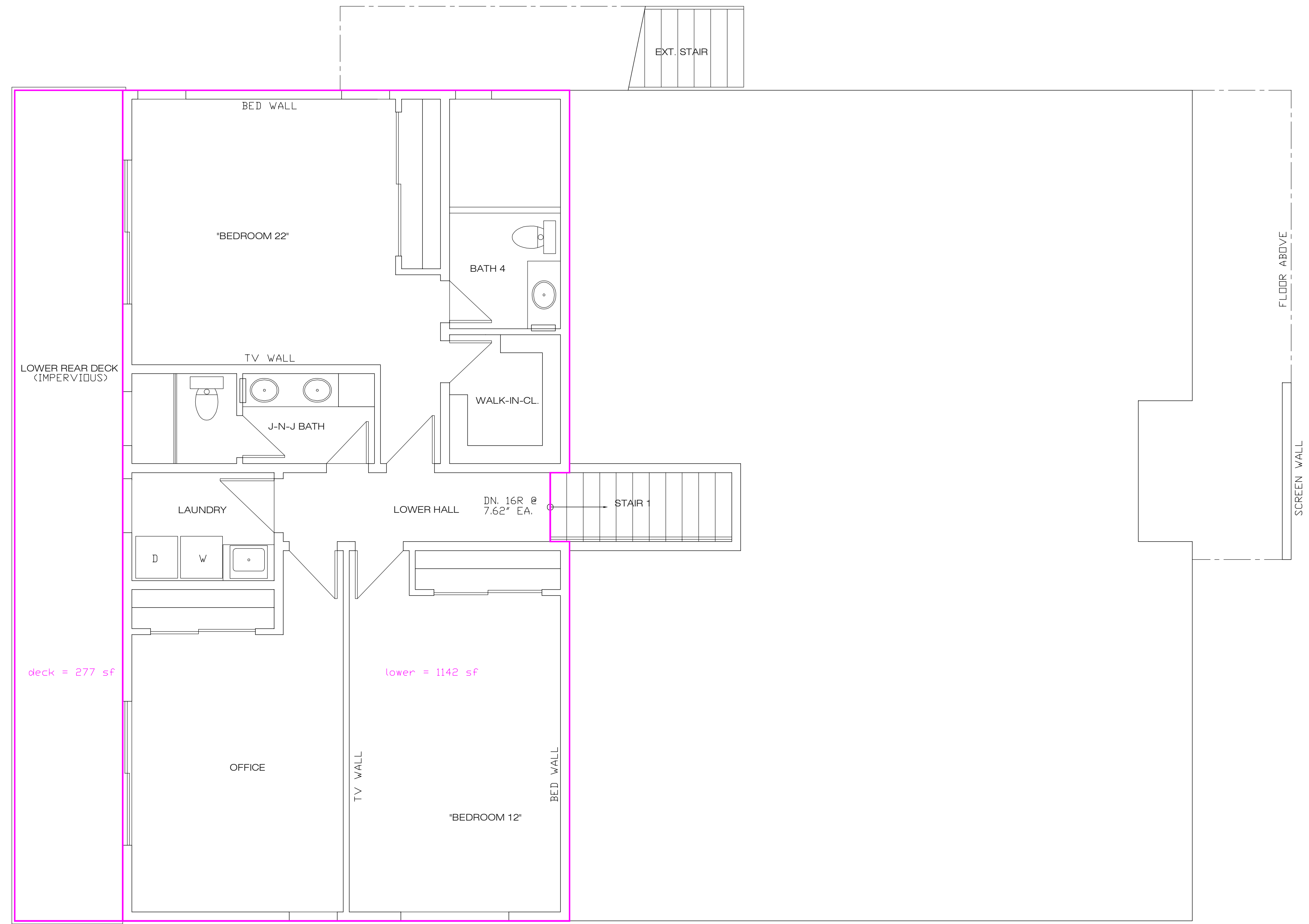

LOWER LEVEL FLOOR PLAN

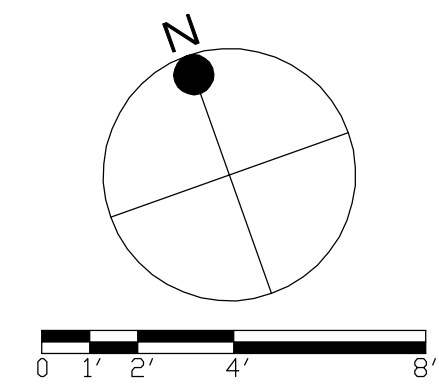

© Copyright 2005- Baukunst  
This drawing is the sole property of the Architect and may not be reproduced or used without the written consent. The right to build only one structure at this project address from these plans is licensed exclusively to this specific project owner.

**CUSTOM RESIDENCE**  
2367 RAINBOW CT.,  
HAYWARD, CA

1/4"=1'-0"

**A2.1**

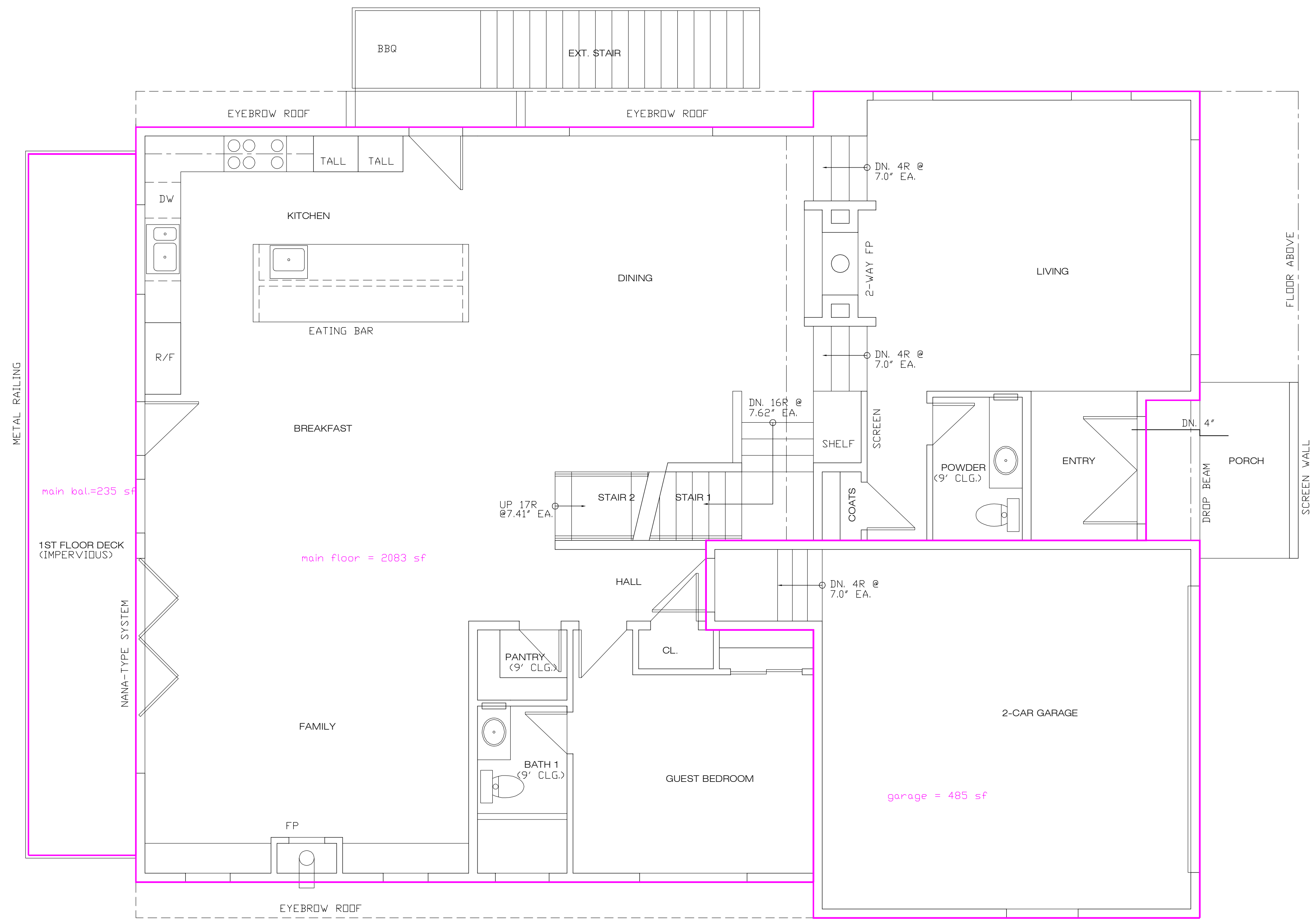

MAIN (STREET) FLOOR PLAN

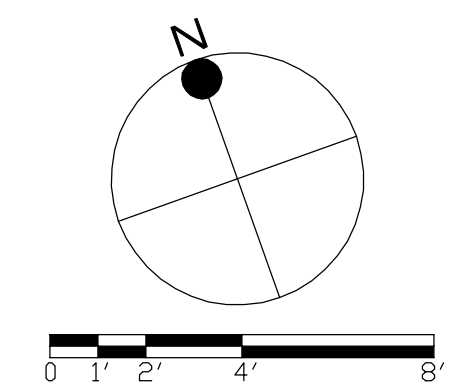

© Copyright 2005- Baukunst  
This drawing is the sole property of the Architect and may not be reproduced or used without the written consent. The right to build only one structure at each project address from these plans is licensed exclusively to this specific project owner.

**CUSTOM RESIDENCE**  
2367 RAINBOW CT.,  
HAYWARD, CA

1/4"=1'-0"

# UPPER LEVEL FLOOR PLAN

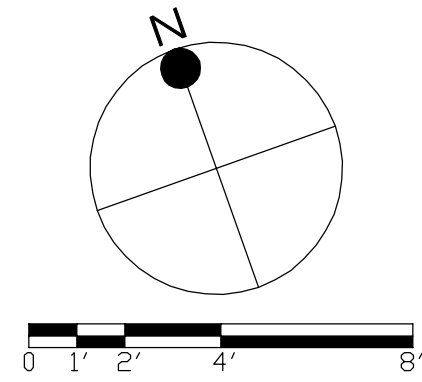
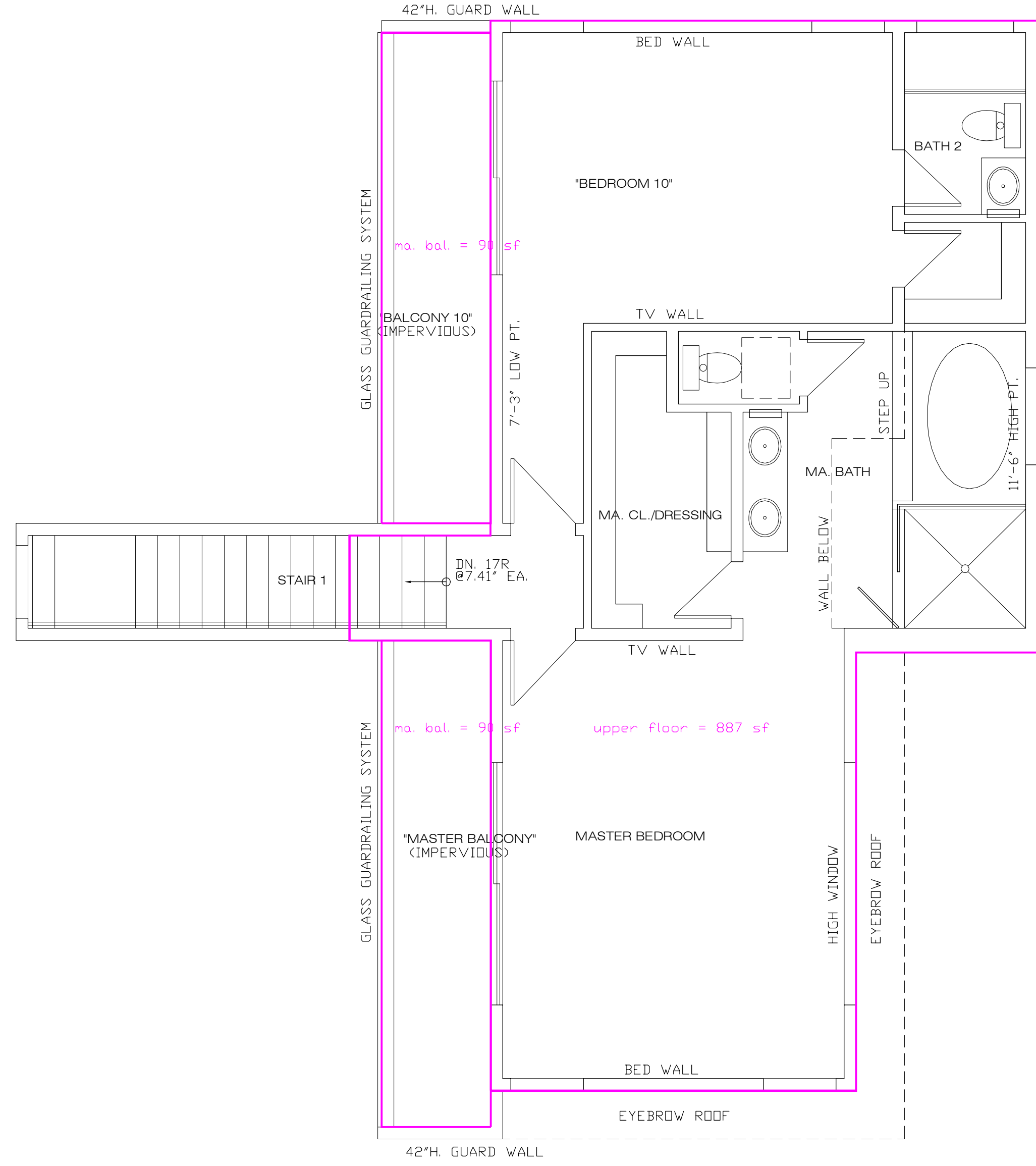

**CUSTOM RESIDENCE**  
 2367 RAINBOW CT.,  
 HAYWARD, CA

1/4"=1'-0"

**A2.3**

**BAUKUNST**  
 88 Fairlawn Avenue, Daly City, CA 94015  
 T: 650.455.1207 F: 650.755.1093  
 E: baukunst2000@yahoo.com W: baukunstarchitecture.com

© Copyright 2005- Baukunst  
 This drawing is the sole property of the Architect and may not be reproduced or used without the written consent. The right to build only one structure at each project address from these plans is licensed exclusively to this specific project owner.

ISSUED FOR \_\_\_\_\_  
 DATE \_\_\_\_\_

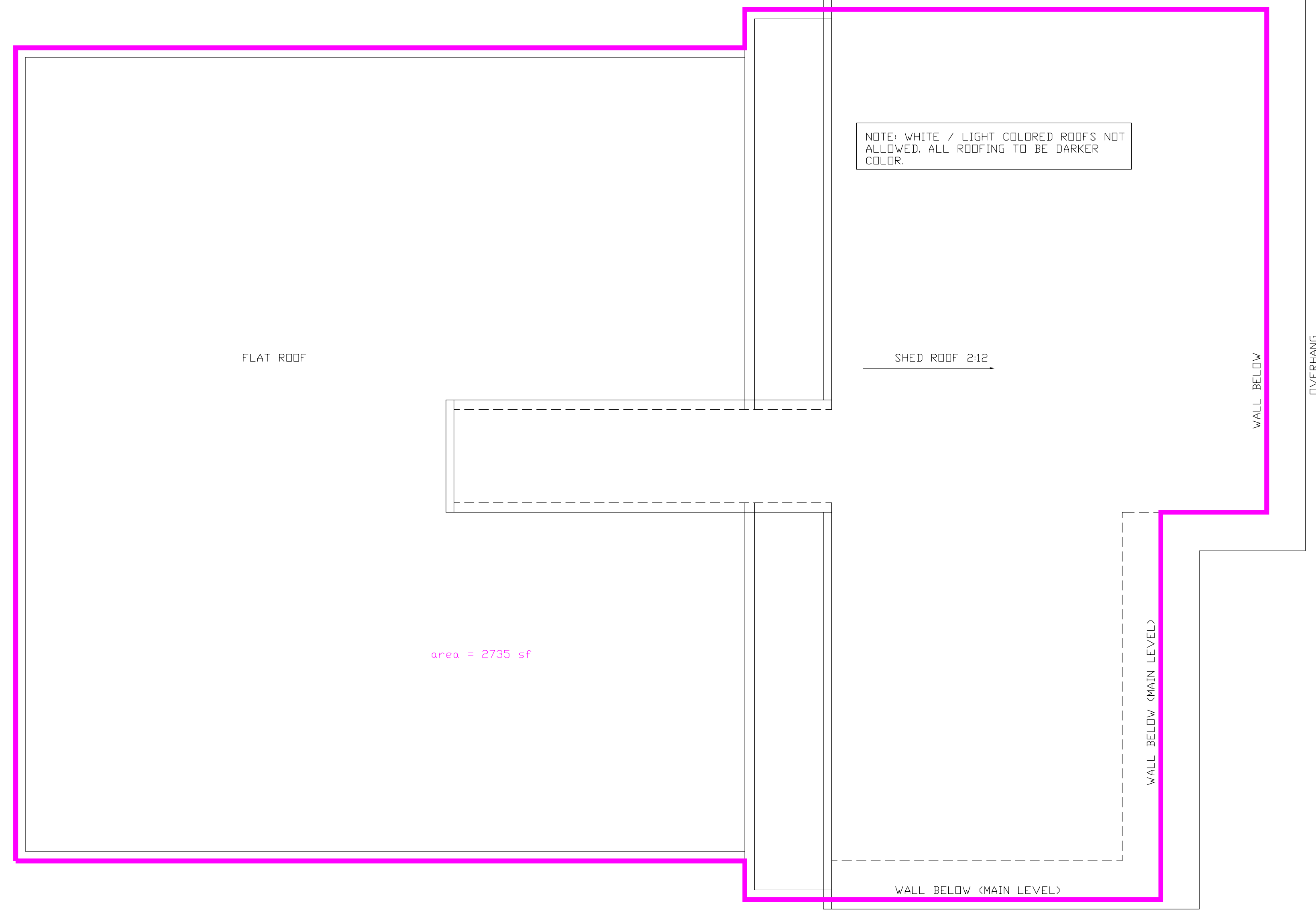

ROOF PLAN

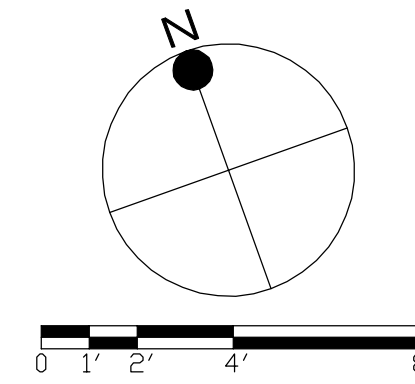

**CUSTOM RESIDENCE**  
 2367 RAINBOW CT.,  
 HAYWARD, CA

1/4"=1'-0"

**A2.4**

**BAUKUNST**

58 Fairlawn Avenue, Daly City, CA 94015  
 T: 650.455.1207 F: 650.755.1093  
 E: baukunst2000@yahoo.com W: baukunstarchitecture.com

© Copyright 2005- Baukunst  
 This drawing is the sole property of the Architect and may not be reproduced or used without the written consent. The right to build only one structure at each project address from these plans is licensed exclusively to the specific project owner.

ISSUED FOR

DATE

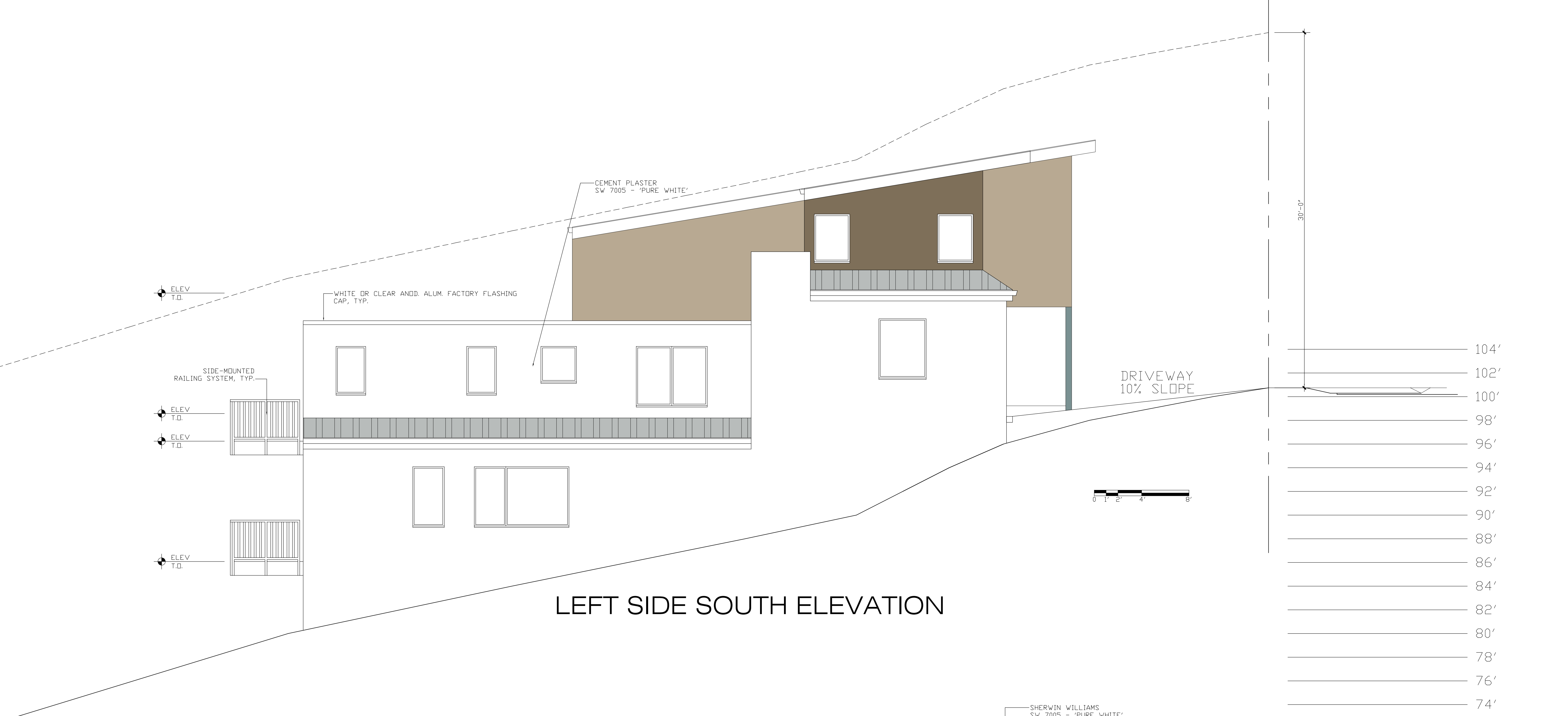

LEFT SIDE SOUTH ELEVATION

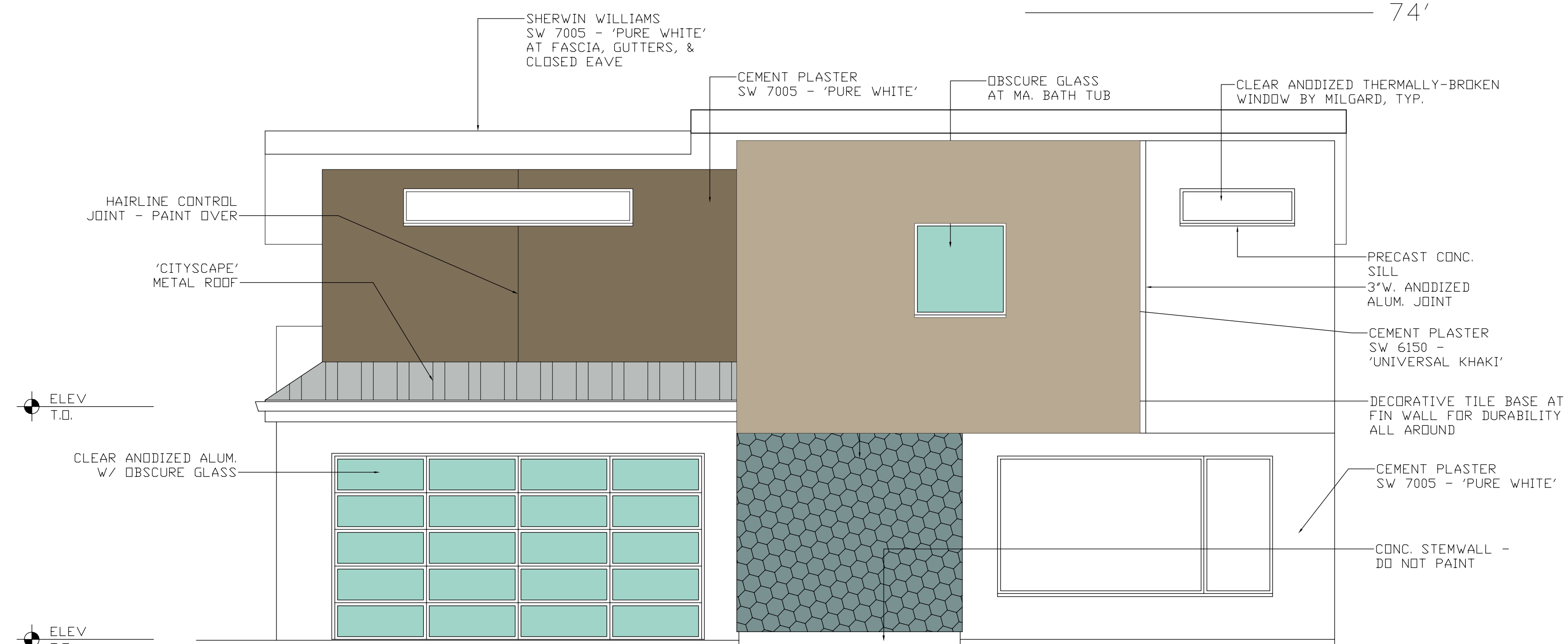

FRONT (STREET) EAST ELEVATION

<p><b>BAUKUNST</b></p> <p>88 Fairlawn Avenue, Daly City, CA 94015          T: 650.455.1207 F: 650.755.1093          E: baukunst2000@yahoo.com W: baukunstarchitecture.com</p> <p>© Copyright 2005- Baukunst          This drawing is the sole property of the Architect and may not be reproduced or used without the written consent. The right to build only one structure at this project address from these plans is licensed exclusively to this specific project owner.</p>	<p>DATE</p> <p>ISSUED FOR</p>
<p><b>CUSTOM RESIDENCE</b></p> <p><b>2367 RAINBOW CT.,</b></p> <p><b>HAYWARD, CA</b></p>	
<p>1/4"=1'-0"</p>	
<p><b>A3.1</b></p>	



104'  
102'  
100'  
98'  
96'  
94'  
92'  
90'  
88'  
86'  
84'  
82'  
80'  
78'  
76'  
74'

RIGHT SIDE NORTH ELEVATION

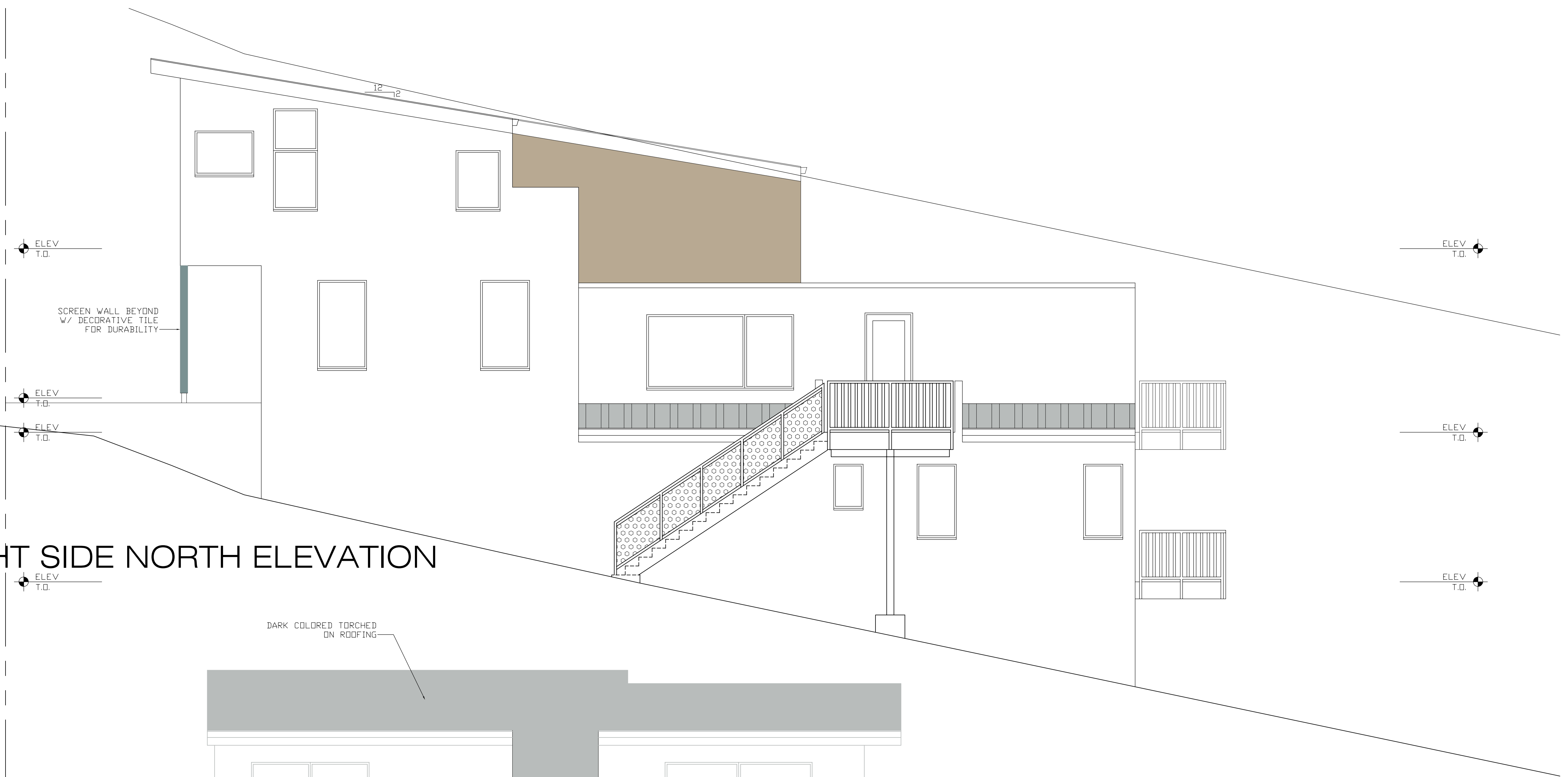

DARK COLORED TORCHED ON ROOFING

REAR WEST ELEVATION

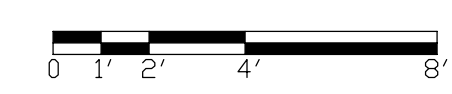
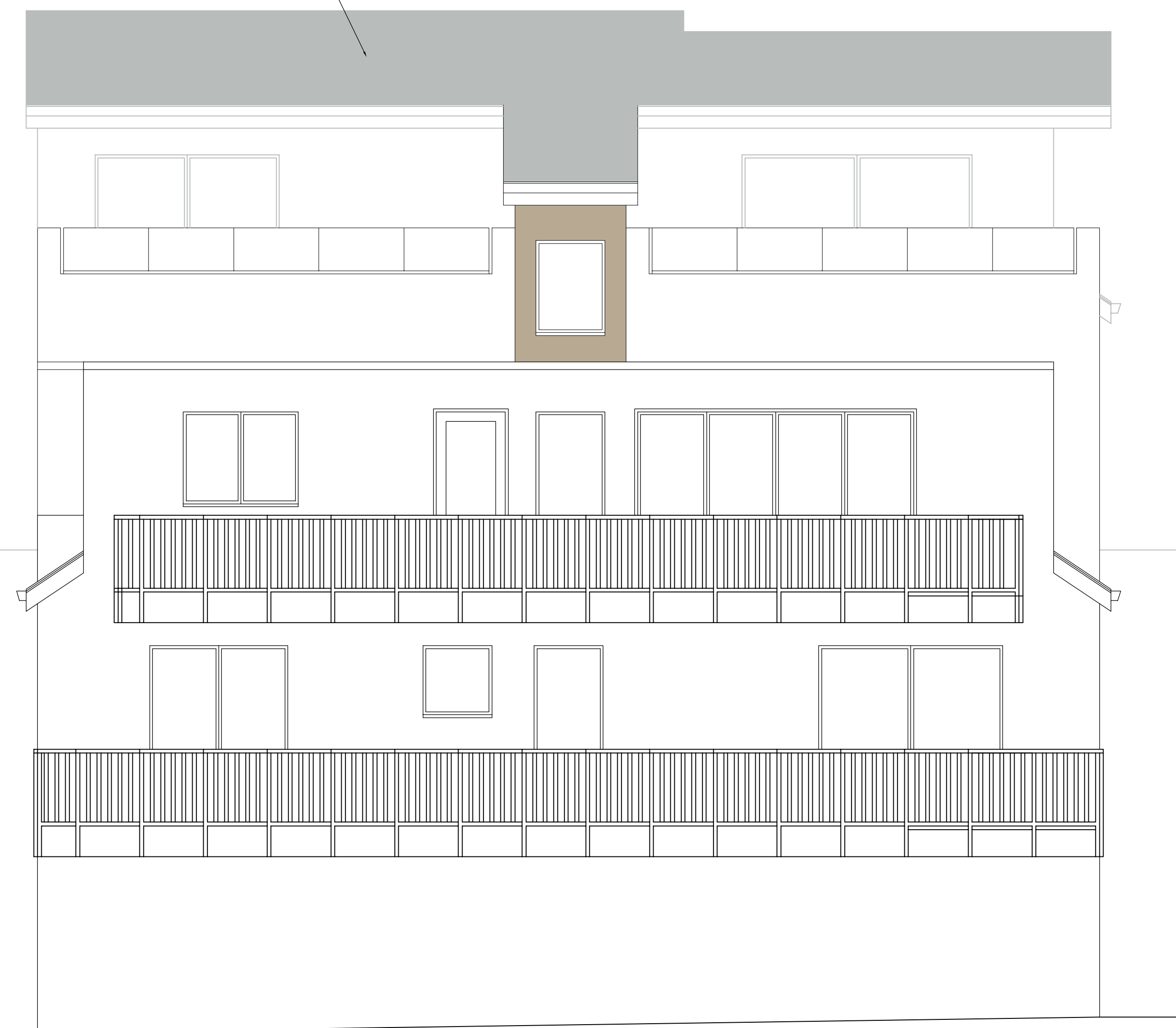

<p>DATE</p>	<p>ISSUED FOR</p>
<p><b>BAUKUNST</b></p> <p>88 Fairlawn Avenue, Daly City, CA 94015 T: 650.455.1207 F: 650.755.1093 E: baukunst2000@yahoo.com W: baukunstarchitecture.com</p> <p>© Copyright 2005- Baukunst This drawing is the sole property of the Architect and may not be reproduced or used without the written consent. The right to build only one structure at said project address from these plans is licensed exclusively to this specific project owner.</p>	
<p><b>CUSTOM RESIDENCE</b> 2367 RAINBOW CT., HAYWARD, CA</p>	
<p>1/4"=1'-0"</p>	
<p><b>A3.2</b></p>	

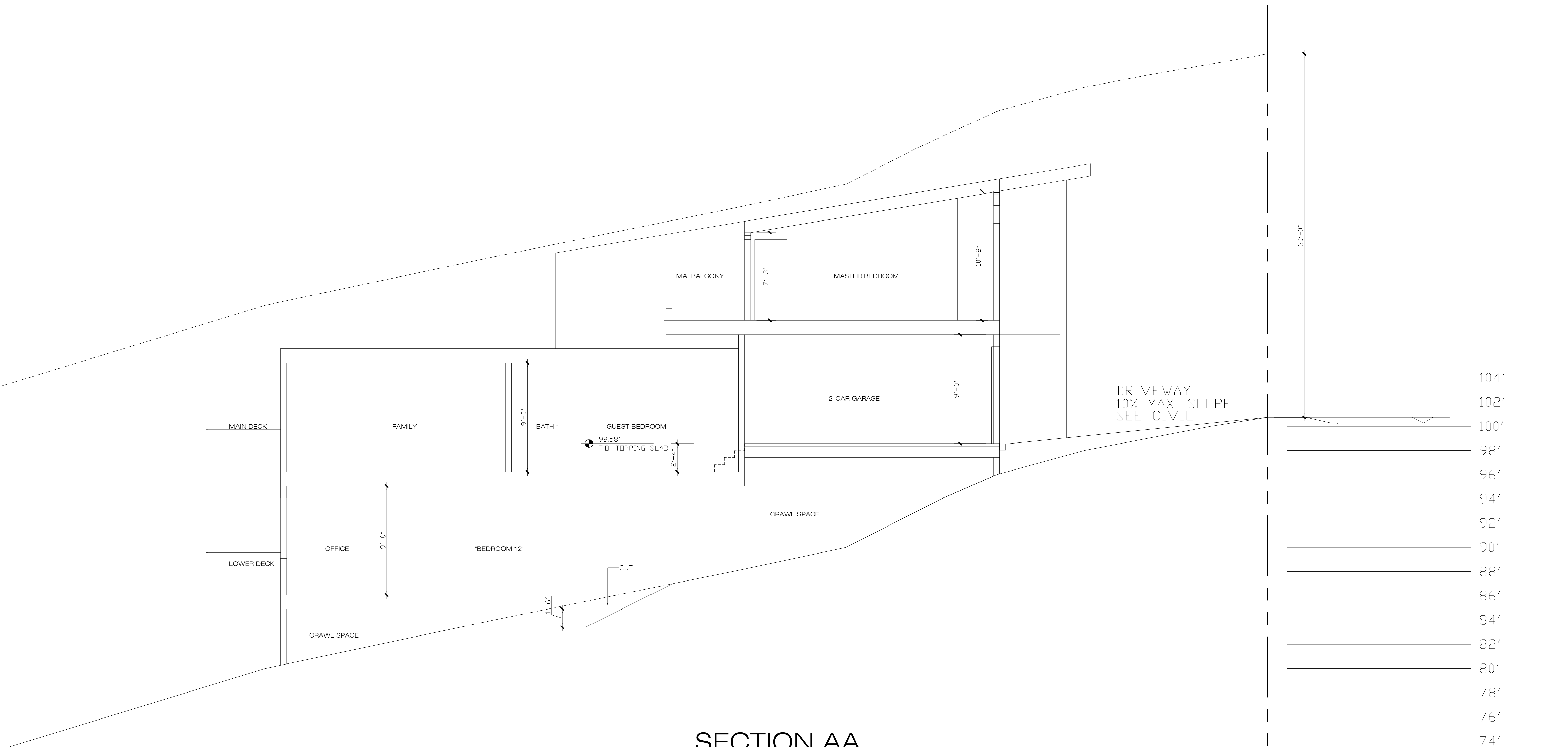

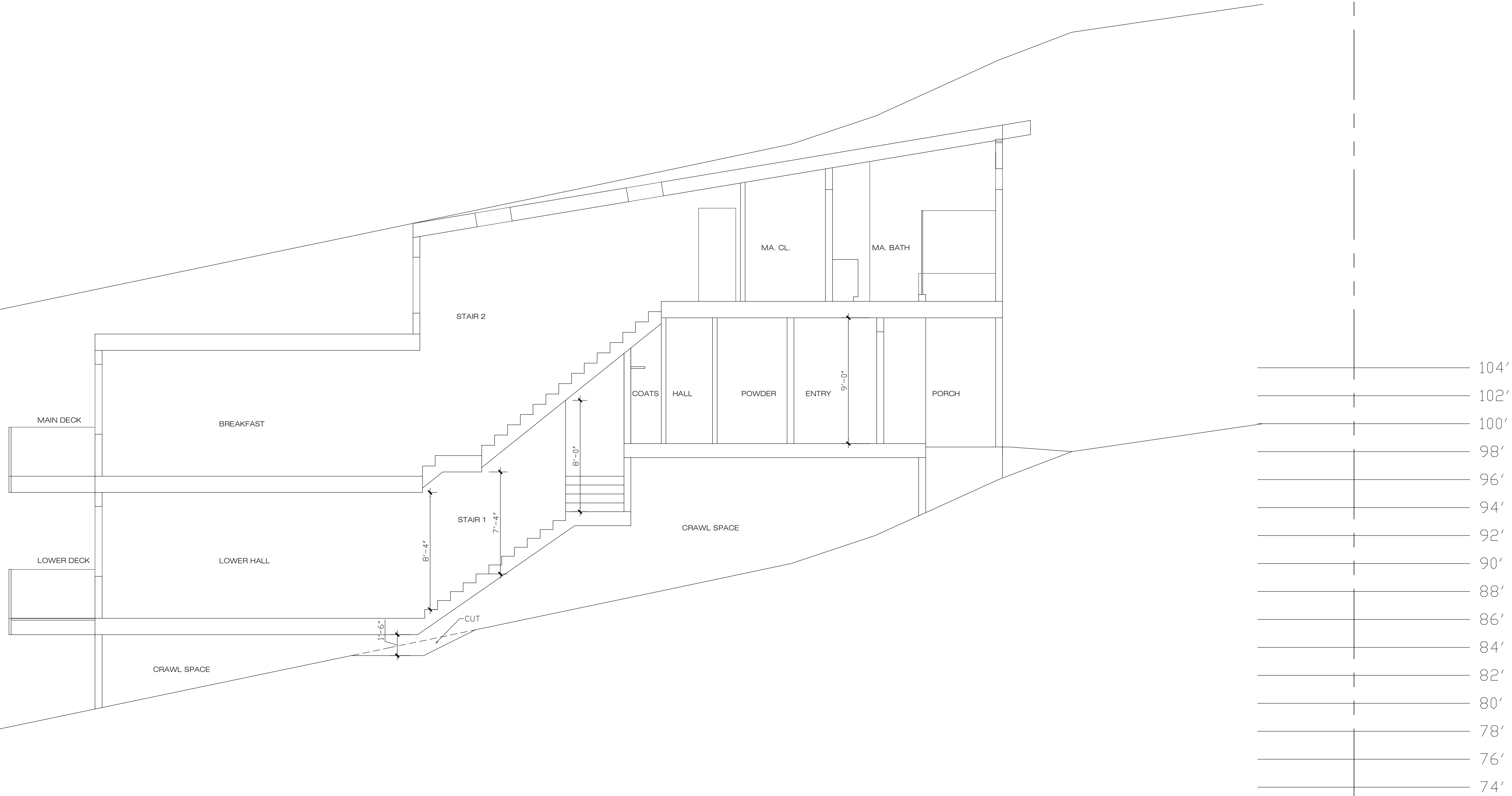

SECTION BB

DATE

ISSUED FOR

**BAUKUNST**

58 Fairlawn Avenue, Daly City, CA 94015  
 T: 650.455.1207 F: 650.755.1093  
 E: baukunst2000@yahoo.com W: baukunstarchitecture.com

© Copyright 2005- Baukunst  
 This drawing is the sole property of the Architect and may not be reproduced or used without the written consent. The right to build only one structure at said project address from these plans is licensed exclusively to the specific project owner.

**CUSTOM RESIDENCE**  
 2367 RAINBOW CT.,  
 HAYWARD, CA

1/4"=1'-0"

**A4.2**

BASIS OF BEARINGS  
 BEARINGS ARE BASED ON TRACT 3992 (126 M 86).  
 MONUMENT LINE IN RAINBOW CT. TAKEN AS N 35°45'24" W

BENCHMARK  
 ASSUMED DATUM.

UTILITY NOTE  
 THE SURFACE UTILITIES SHOWN ON THIS DRAWING HAVE BEEN LOCATED BY FIELD SURVEY. THE UNDERGROUND UTILITIES SHOWN HAVE BEEN COMPILED FROM RECORDS OF THE VARIOUS AGENCIES. THE SURVEYOR ASSUMES NO RESPONSIBILITY FOR THEIR INDICATED LOCATION, SIZE OR TYPE. RECORD UTILITY INFORMATION SHOULD BE CONFIRMED BY EXPOSING THE UTILITY.

NOTES  
 1) OWNER: QUAN TRAN.  
 2) SITE ADDRESS: 2367 RAINBOW CT., HAYWARD, CA 94542.  
 3) APN: 0425-0410-026.

SURVEYOR'S STATEMENT  
 THIS MAP CORRECTLY REPRESENTS A SURVEY MADE BY ME OR UNDER MY DIRECTION IN CONFORMANCE WITH THE REQUIREMENTS OF THE CALIFORNIA LAND SURVEYOR'S ACT AT THE REQUEST OF QUAN TRAN ON OCTOBER 10, 2016.

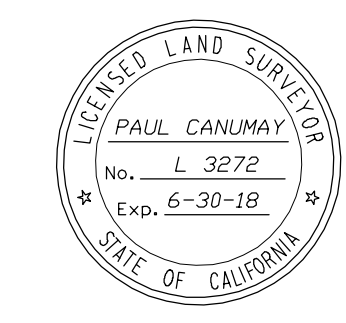

PAUL CANUMAY, PLS 3272  
 LICENSE EXPIRES JUNE 30, 2018  
 DATE \_\_\_\_\_

- LEGEND
- FOUND STANDARD STREET MONUMENT
  - SET 5/8" REBAR & CAP (PLS 3272)
  - SET NAIL & TAG (PLS 3272)
  - TBC TOP OF BACK OF CURB
  - FL FLOW LINE OF CURB
  - P/L PROPERTY LINE
  - LG LIP OF GUTTER
  - WM WATER METER
  - BW BACK OF WALK

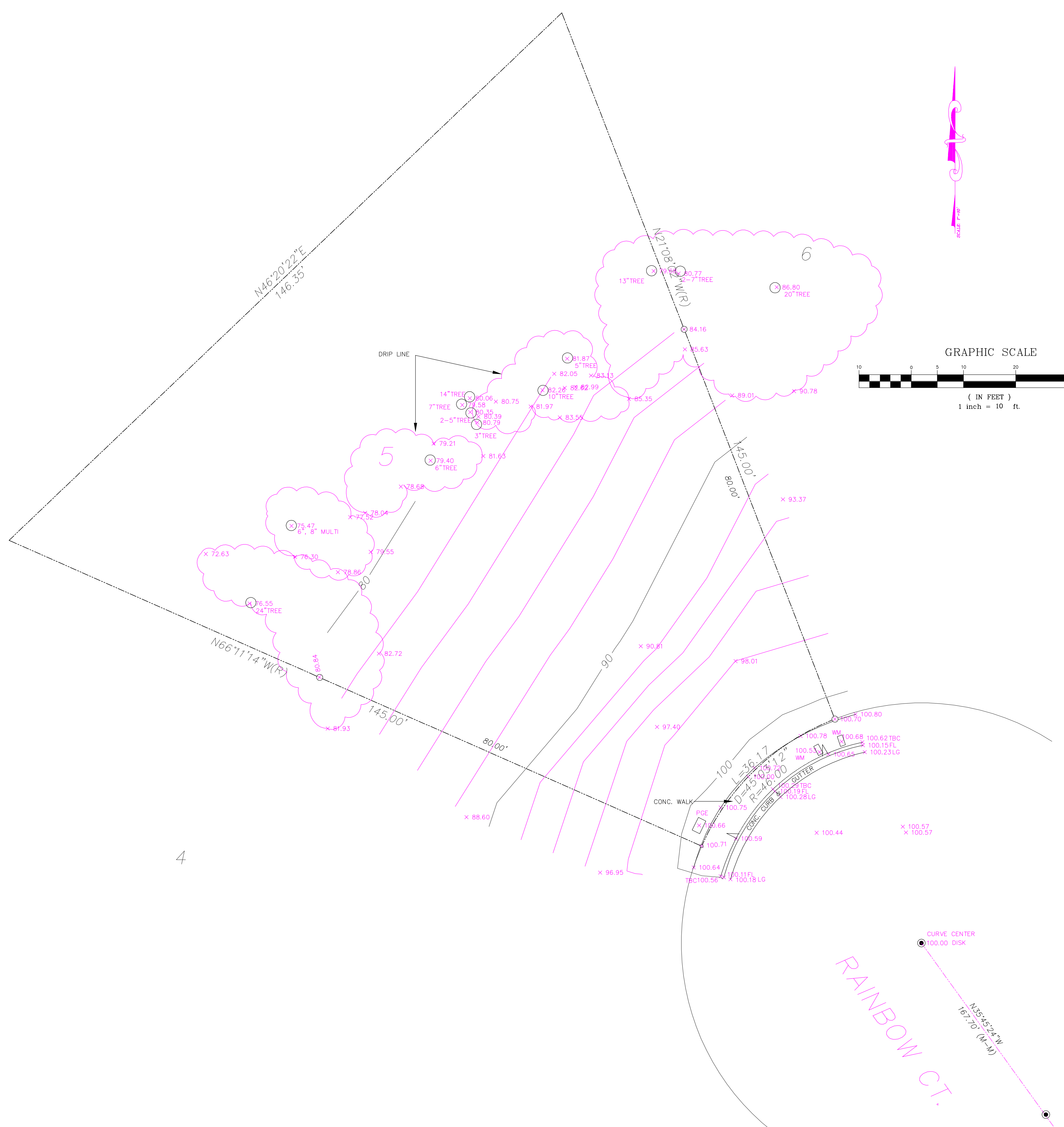
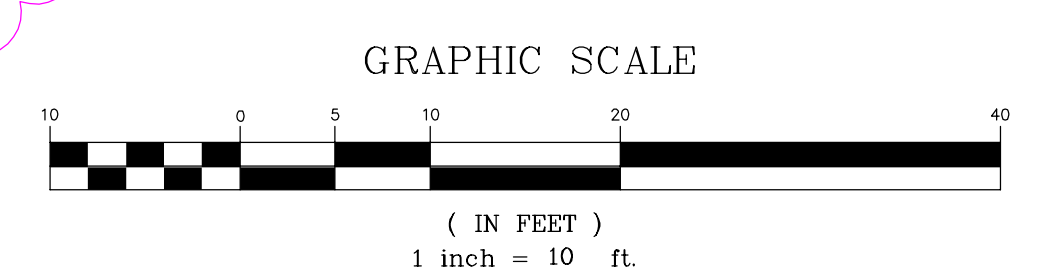

# BOUNDARY AND TOPOGRAPHIC SURVEY

LOT 5, TRACT 3992 FILED 4/23/1981  
 (126 M 86), ALAMEDA COUNTY RECORDS  
 HAYWARD CALIFORNIA

SCALE: 1" = 10' DECEMBER 10, 2017

CANUMAY LAND SURVEYING  
 P.O. BOX 121  
 BENICIA, CALIFORNIA  
 (707) 747-0458

4

PRELIMINARY DRAWINGS ONLY - NOT FOR CONSTRUCTION

DATE	ISSUES & REVISIONS	NO.
05/31/18	DR RESUB.	3
02/14/18	DR RESUB.	2
08/15/17	DR SUB.	1



PROJECT# 1728 DRAWN BY: TK  
 ORIGINAL DRAWING SIZE: 24" X 36"  
 SCALE: 1/8" = 1' - 0"

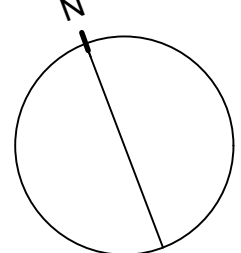

**MATERIALS PLAN**  
 SHEET #



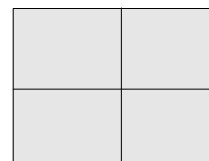
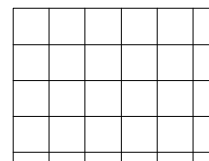
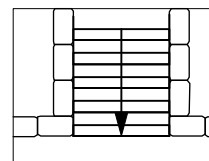
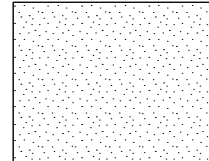
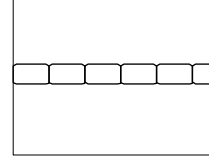

**DD-1**

All written material appearing herein constitutes original unpublished work of the landscape architect and may not be duplicated, used or disclosed without the written consent of the landscape architect.

**MATERIALS LEGEND**

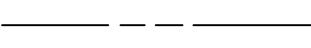
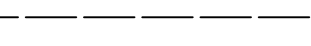
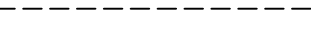
-  (N) CONCRETE DRIVEWAY / PAVING  
SCORED AND COLORED CONC.  
COLOR: WINTER BEIGE  
FINISH: SAND
-  (N) CUT STONE ENTRY PAVING
-  (N) LANDSCAPE TIE STAIRS  
W/ SIERRA TAN CRUSHED ROCK AND  
(N) SECTIONAL 'VERSA LOK' WALL
-  SIERRA TAN CRUSHED ROCK PATH
-  (N) SECTIONAL 'VERSA LOK' RETAINING  
WALL TO 30"

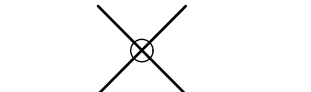
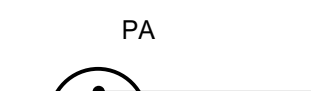
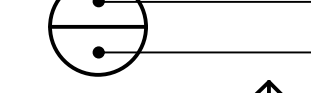
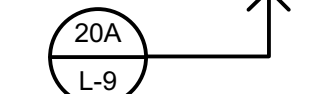
**LEGEND**

-  PROPERTY LINE
-  SETBACK
-  OVERHEAD STRUCTURE
-  (E) TREE CANOPY
-  (E) TREE TO BE REMOVED
-  PA PLANTING AREA
-  DETAIL NUMBER
-  SHEET NUMBER
-  DETAIL SECTION

**TREE REMOVAL CHART**

#	COMMON NAME	SPECIES	DIAMETER (INCHES)	TREE REMOVAL
# 1	COAST LIVE OAK	QUERCUS AGRIFOLIA	14"	TO BE REMOVED
# 2	COAST LIVE OAK	QUERCUS AGRIFOLIA	24"	
# 3	COAST LIVE OAK	QUERCUS AGRIFOLIA	6' 8"	
# 4	COAST LIVE OAK	QUERCUS AGRIFOLIA	6"	TO BE REMOVED
# 5	COAST LIVE OAK	QUERCUS AGRIFOLIA	3"	TO BE REMOVED
# 6	COAST LIVE OAK	QUERCUS AGRIFOLIA	2-5"	TO BE REMOVED
# 7	COAST LIVE OAK	QUERCUS AGRIFOLIA	7"	
# 8	COAST LIVE OAK	QUERCUS AGRIFOLIA	14"	
# 9	COAST LIVE OAK	QUERCUS AGRIFOLIA	10"	
# 10	COAST LIVE OAK	QUERCUS AGRIFOLIA	5"	
# 11	COAST LIVE OAK	QUERCUS AGRIFOLIA	13"	

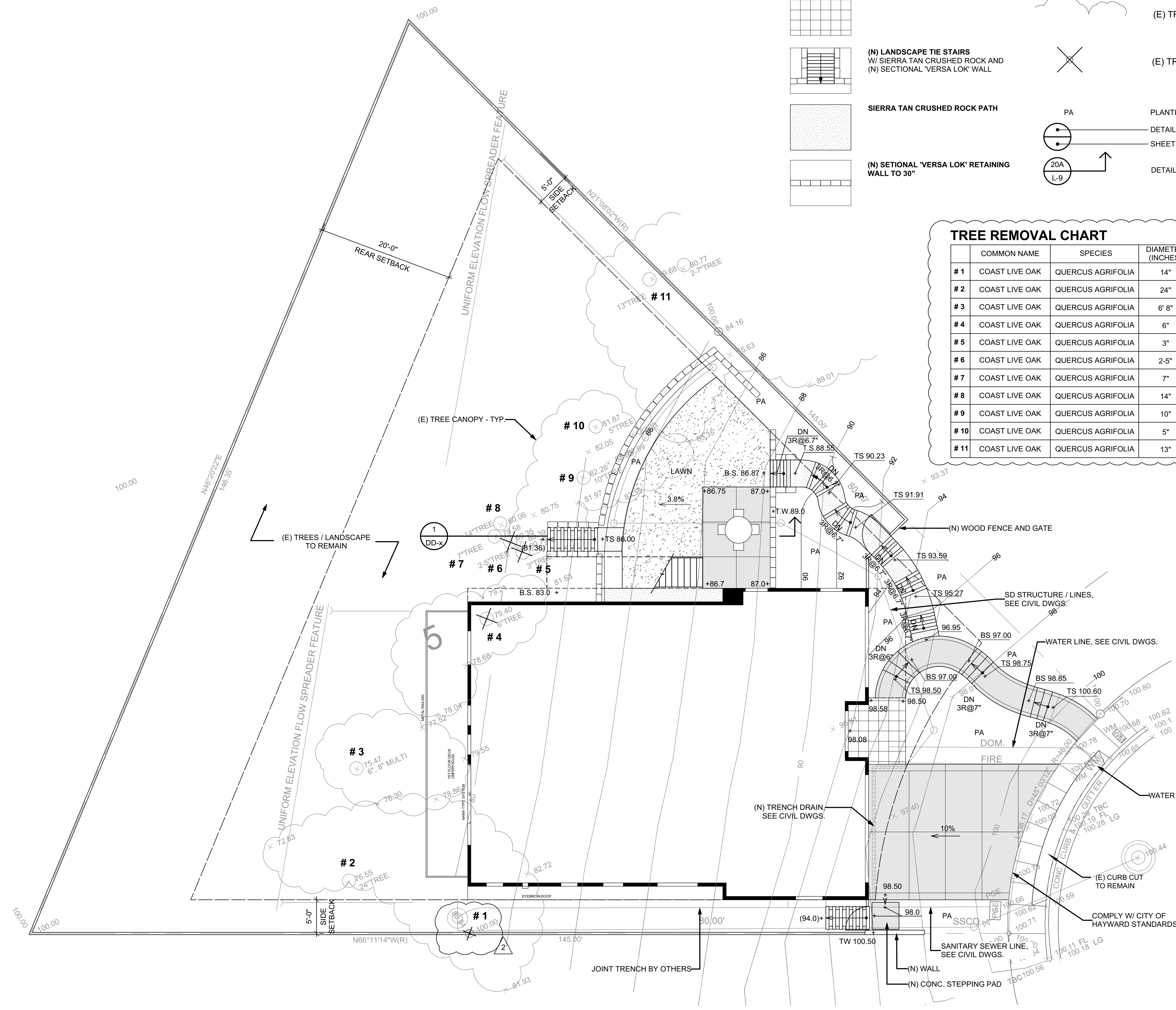

**NOTE:**  
 REFER TO CIVIL ENGR. PLAN FOR GRADING PLAN



# LIGHTING LEGEND

SYMBOLS	DESCRIPTION	QUAN.	MANUF.	MODEL	WATT	LAMP	VOLTAGE	FINISH/ COLOR	NOTES
	PATH LIGHT	7	HADCO LIGHTING	GAL3		LED	12V	COPPER	
	WALL LIGHT	3	B-K LIGHTING	SQUARE STAR		LED	12V	BRASS	
	UP LIGHT	1	HADCO LIGHTING	MR16		LED	12V	BRASS	

## LIGHTING NOTES

PROVIDE SWITCHING, TRANSFORMER LAYOUT AND WIRE SIZE FOR REVIEW BY LANDSCAPE ARCHITECT.

SIZE LOW VOLTAGE WIRE BASED ON A MAX. ALLOWABLE VOLTAGE DROP OF 50%

TRANSFORMERS SIZED TO MAXIMUM CAPACITY OF LIGHT FIXTURE.

DESIGN LOAD IS TO NOT EXCEED 80% OF TRANSFORMER CAPACITY.

PROVIDE ALL NECESSARY LOAD DESIGN AND CODE COMPLIANCE FOR PERMIT REQUIREMENTS. THE CONTRACTOR WILL ACQUIRE AND THE OWNER WILL PAY FOR THE PERMIT. THE WORK IS TO COMPLY WITH ALL APPLICABLE CODES AND STANDARDS AND MEET ALL TESTING REQUIREMENTS.

FIXTURE LOCATIONS AND WIRE LAYOUTS ARE DIAGRAMMATIC AND APPROXIMATE. BEFORE INSTALLATION, REVIEW ADJACENT ARCHITECTURAL FEATURES WITH THE LANDSCAPE ARCHITECT AND INSTALL AS DIRECTED. ARRANGE TRANSFORMERS AND CONTROLLER IN AN ORDERLY FASHION TO ALLOW ACCESS AS NECESSARY.

REFER TO THE PLAN FOR LIGHT FIXTURE LOCATION. UTILIZE (E) CONDUIT TIE TO (E) SWITCHING WHERE POSSIBLE.

BALANCE LOADS TO THE TRANSFORMERS, IDENTIFY "CENTER OF LOAD," CONNECT WIRE FROM TRANSFORMER TO "CENTER OF LOAD."

PROVIDE 120 VOLT POWER TO EACH REMOTE TRANSFORMER CONNECT TO SWITCH IN HOUSE PER DIRECTION AND ACCEPTANCE OF OWNER.

# PLANTING LEGEND

Symbol	Latin Name	Common Name	Quantity	Size	Mature Size	Water Use Rating	Native Plant	Fire Resistant	Remarks
<b>Trees</b>									
COR KOU	Cornus kousa	Kousa Dogwood	1	24" Box	20' x 20'	M	N	N	
LAG MUS	Lagerstroemia 'Muskegoe'	Crape Myrtle	1	24" Box	25' x 12'	L	N	N	Standard
QUE AGR	Quercus agrifolia	Coast Live Oak	2	24" Box	50' x 50'	VL	Y	N	
<b>Shrubs</b>									
CHO TER	Choisya ternata	Mexican Orange	2	5 Gal.	6' x 6'	M	N	N	
LAV PRO	Lavandula x intermedia 'Provence'	'Provence' Lavender	21	1 Gal.	2' x 3'	L	N	N	
WES MOR	Westringia fruticosa 'Morning Light'	Morning Light Westringia	5	5 Gal.	4' x 6'	L	N	N	
<b>Perennials</b>									
DIA VAR	Dianella tasmanica 'Variegata'	Variegated Flax Lily	40	1 Gal.	3'6" x 2'0"	M			
EUP TAS	Euphorbia characias 'Tasmanian Tiger'	Variegated Spurge	16	1 Gal.	4' x 4'	L	N	N	
PHO YEL	Phormium 'Yellow Wave'	Variegated New Zealand Flax	3	5 Gal.	4' x 6'	L	N	N	
SEN SER	Senecio serpens	Blue Chalk Stick	20	1 Gal.	12"x10"	L	N	Y	24" O.C.
<b>Ferns</b>									
ASP MEY	Asparagus meyeri	Foxtail Fern	8	1 Gal.	2' x 3'	M	N	N	
<b>Grasses</b>									
FES ELI	Festuca glauca 'Elijah Blue'	Common Blue Fescue	37	1 Gal.	1' x 1'	L	N	N	
PEN ORI	Pennisetum orientale	Chinese Fountain Grass	15	1 Gal.	2' x 2'6"	M	N	Y	
<b>Vines</b>									
<b>Bulbs</b>									
<b>Groundcovers</b>									

1

2

1

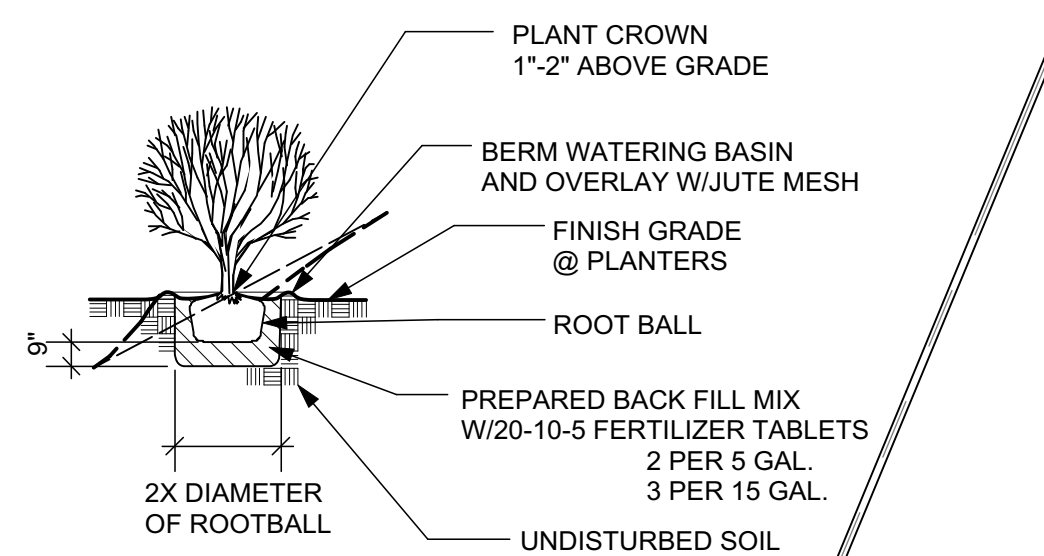
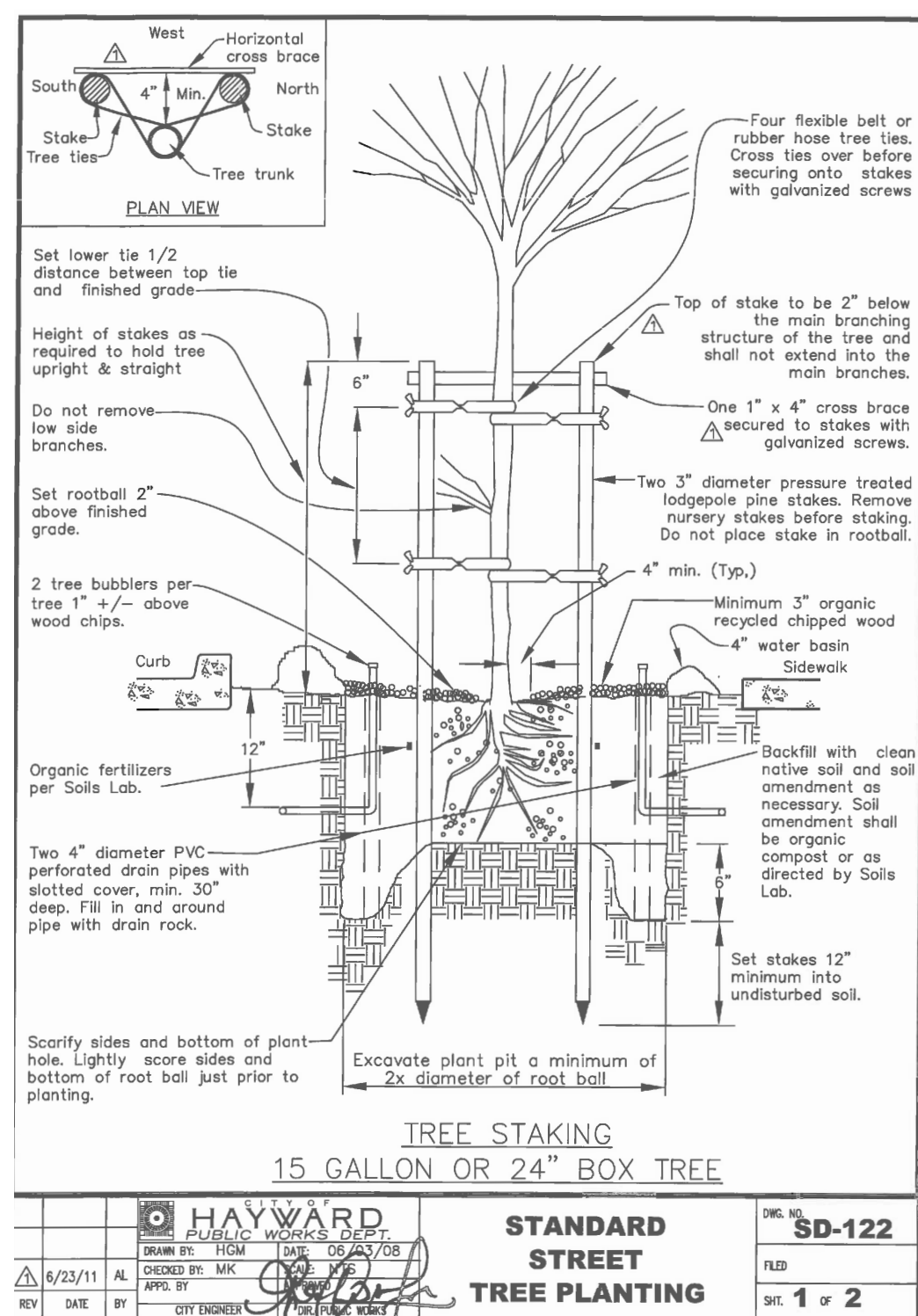

1

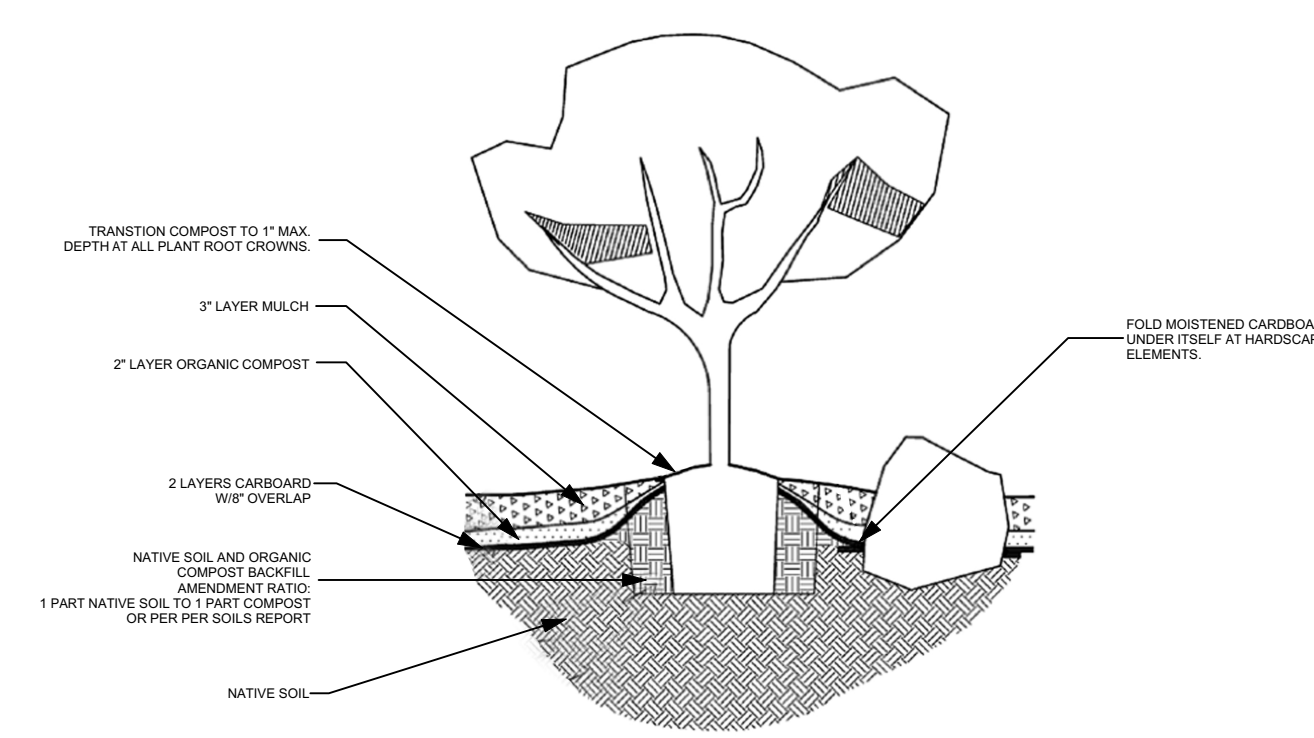
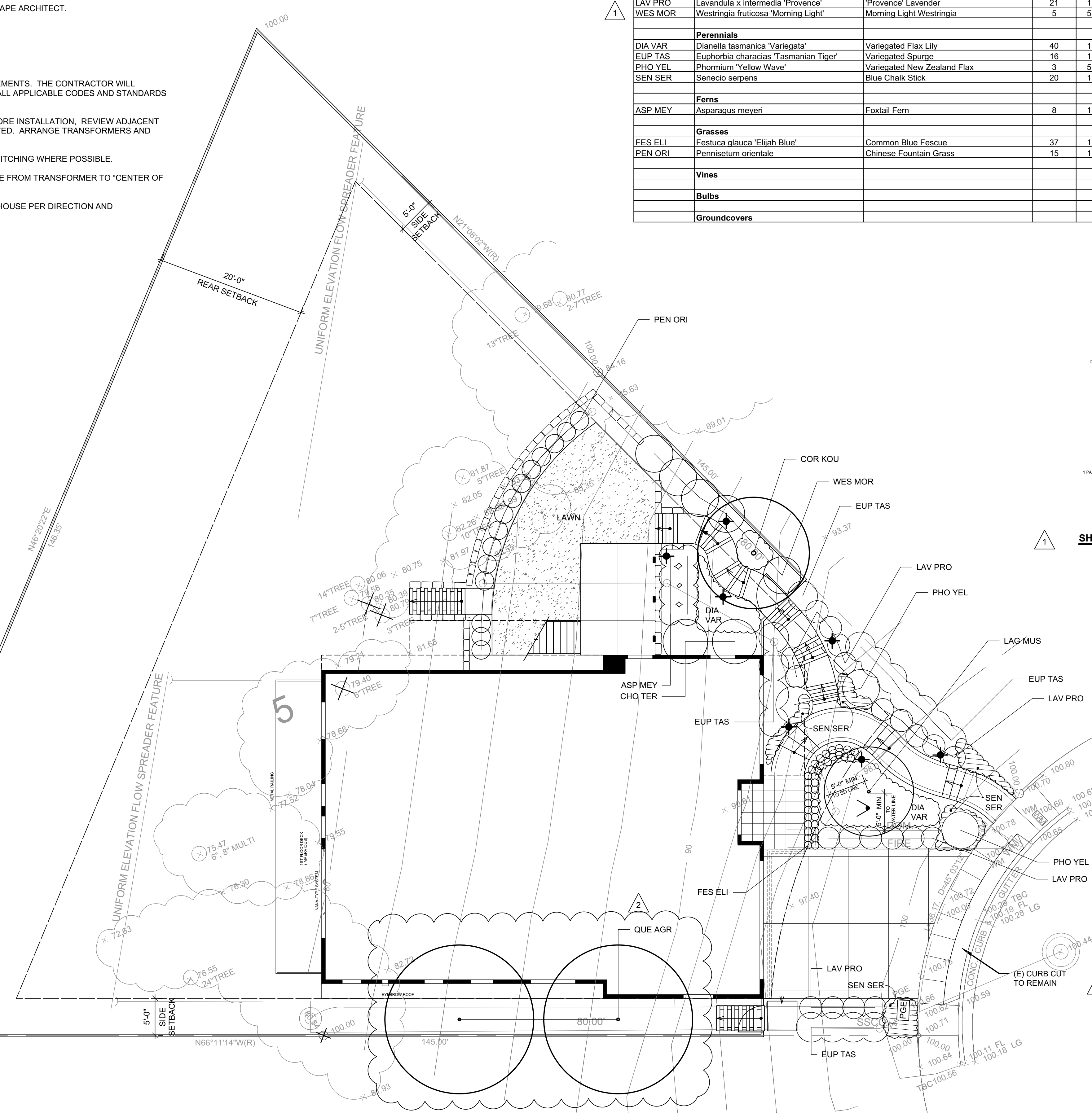

1 SHEET MULCH DETAIL

## LANDSCAPE NOTES

PLANT SYMBOLS REPRESENT A 3-5 YEAR GROWTH PROJECTION.

PLANTING SHALL BE PERFORMED BY PERSONS FAMILIAR WITH THIS TYPE OF WORK AND UNDER THE SUPERVISION OF A QUALIFIED FOREMAN.

STAKE OR GUY TREES PER DETAILS.

CONTRACTOR SHALL COORDINATE ALL PLANTING WITH UTILITY LOCATIONS NOT SHOWN ON THE PLANS. ANY CONFLICTS BETWEEN LOCATIONS OF PROPOSED SITE UTILITIES OR LIGHTING SHALL BE CALLED TO THE ATTENTION OF THE LANDSCAPE ARCHITECT.

ALL EXISTING TREES SHALL REMAIN AND PROTECTED IN PLACE, UNLESS DESIGNATED TO BE REMOVED OR TRANSPLANTED.

PLANTING HOLES TO BE TILLED SO THAT THE SOIL IS LOOSE AND NOT COMPACTED TO A MINIMUM DEPTH OF 8". COMPACTED SOILS SHALL BE RIPPED TO 10" DEPTH AND GRADED SMOOTH TO TRANSITION TO SURROUNDING AREAS.

SOIL TESTS (THERE SHALL BE A MINIMUM OF 6) SHALL BE PERFORMED ON THE EXISTING SOIL TO DETERMINE THE FINAL AMENDMENT AND FERTILIZER FORMULA. THE SOILS REPORT SHALL CONTAIN THE FOLLOWING INFORMATION:  
 SOIL PERMEABILITY RATE IN INCHES PER HOUR  
 SOIL TEXTURE TEST  
 CATION EXCHANGE CAPACITY  
 SOIL FERTILITY (including tests for nitrogen, potassium, phosphorous, pH, organic matter and electrical conductivity)  
 RECOMMENDATIONS FOR AMENDMENTS TO THE PLANTING AREA SOIL

SHEET MULCH ALL PLANTING AREAS; AMEND PER THE RECOMMENDATIONS OF THE SOILS REPORT.

FURNISH AND INSTALL A 3" LAYER OF MULCH, PLUS A 2" LAYER OF COMPOST OVER TWO PLYS OF RECYCLED CARDBOARD IN ALL PLANTING AREAS. MULCH TO BE ORGANIC RECYCLED CHIPPED WOOD IN DARK BROWN COLOR; "BLACK MINI" OR "#5 RECYCLED CHIP" MULCH FROM UNITED FOREST PRODUCTS OR "FOREST FLOOR" MULCH FROM AMERICAN SOIL PRODUCTS. TRANSITION MULCHES TO 1" DEPTH AT ALL PLANT ROOT CROWNS. PLANT ALL MATERIALS 2" MINIMUM ABOVE EXISTING SOIL LEVELS.

THE CONTRACTOR SHALL GUARANTEE TREES FOR A PERIOD OF 1 YEAR.

THE CONTRACTOR SHALL GUARANTEE PLANTED STOCK FOR A 90-DAY MAINTENANCE PERIOD AFTER FINAL ACCEPTANCE BY THE OWNER.

PRELIMINARY DRAWINGS ONLY - NOT FOR CONSTRUCTION

DATE	ISSUES & REVISIONS	NO.
05/31/18	DR RESUB.	3
02/14/18	DR RESUB.	2
08/15/17	DR SUB.	1



PROJECT# 1728 DRAWN BY: TK  
ORIGINAL DRAWING SIZE: 24" X 36"

SCALE: 1/8" = 1' - 0"

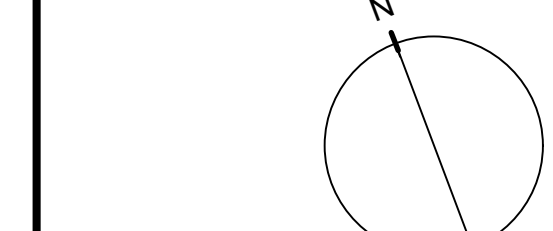

## DD PLANTING/ LIGHTING PLAN

SHEET #

# DD-2

All written material appearing herein constitutes original unpublished work of the landscape architect and may not be duplicated, used or disclosed without the written consent of the landscape architect.

LANDSCAPE WATER USE STATEMENT

Project Name: Rainbow Court Project  
 Project Address: 2357 Rainbow Court, Hayward, CA  
 Prepared by: Pedersen Associates  
 Name: License or Cert. No. (if applicable):  
 24 H Street, San Rafael, CA (415)456-2070  
 Address: Telephone Number:  
 10/19/2017  
 Date:

PART ONE Landscape Water Allowance

Total Irrigated Landscaped Area (square feet)	Box A
	1,402
	x 20.8
Landscape Water Allowance (Gallons per Year)	Box B
	29,161

PART TWO Estimated Landscape Water Use

\*ELWU = LZ x PF x IE

Landscape Zone	Area (LZ) (square feet)	Plant Factor (PF)	Irrigation Efficiency (IE)	ELWU (Gallons/Year)
1	39	0.5	0.85	596
2	457	0.2	0.85	2,796
3	531	0.5	0.85	8,121
4	375	0.7	0.825	10,920
<b>TOTAL</b>	<b>1,402</b>			<b>22,433</b>

I HAVE COMPLIED WITH THE CRITERIA OF CITY OF HAYWARD BAY-FRIENDLY WATER EFFICIENT LANDSCAPE ORDINANCE AND APPLIED THEM FOR THE EFFICIENT USE OF WATER IN THE LANDSCAPE, GRADING AND IRRIGATION DESIGN PLAN.

IRRIGATION SPECIFICATION:

THIS SPECIFICATION IS TO ESTABLISH PERFORMANCE STANDARDS FOR BIDDER-DESIGNED IRRIGATION SYSTEM PER BAY FRIENDLY WATER EFFICIENT LANDSCAPE ORDINANCE.

THE IRRIGATION SYSTEM SHALL BE DESIGNED TO OPERATE AT 70-75 PSI AT POINT OF CONNECTION. TOTAL DEMAND FOR ANY ONE STATION SHALL NOT EXCEED 10 G.P.M.

IRRIGATION SYSTEM SHALL BE INSTALLED IN CONFORMANCE WITH ALL APPLICABLE STATE AND LOCAL CODES AND ORDINANCES BY A LICENSED LANDSCAPE CONTRACTOR AND EXPERIENCED WORKMEN. THE CONTRACTOR SHALL OBTAIN ALL NECESSARY PERMITS AND FEES.

CONTRACTOR TO CONFIRM LOCATION OF EXISTING UTILITIES AND UNDER GROUND STRUCTURES PRIOR TO THE EXCAVATION OF TRENCHES. CONTRACTOR SHALL REPAIR ANY DAMAGE CAUSED BY, OR DURING THE PERFORMANCE OF HIS WORK AT NO ADDITIONAL COST TO THE OWNER. VERIFY POINT OF CONNECTION WITH THE LANDSCAPE ARCHITECT PRIOR TO BEGINNING CONSTRUCTION.

CONTRACTOR TO GUARANTEE COMPLETE IRRIGATION COVERAGE. THE CONTRACTOR SHALL SIZE AND LOCATE LATERAL LINES AND SLEEVE AS REQUIRED. PARALLEL PIPES MAY BE INSTALLED IN A COMMON TRENCH. PIPES SHALL HAVE A THREE INCH HORIZONTAL SEPARATION AND ARE NOT TO BE INSTALLED DIRECTLY ABOVE ONE ANOTHER.

TRENCHES ARE TO BE OF SUFFICIENT DEPTH TO PROVIDE EIGHTEEN INCHES OF COVER OVER MAIN LINES AND CONTROL WIRE AND TWELVE INCHES OF COVER OVER LATERAL LINES. SLEEVED LINES SHALL HAVE A MINIMUM COVER OF TWELVE INCHES. BACKFILL TRENCHES WITH MATERIAL FREE OF ROCKS.

INSTALL BACKFLOW PREVENTER PER MANUFACTURER'S SPECIFICATIONS. BACKFLOW PREVENTER SHALL BE INSTALLED PLUMB AND IN ALIGNMENT WITH ADJACENT PAVEMENT EDGES OR STRUCTURES.

USE ONLY ONE TYPE SERIES HEAD ON ANY CIRCUIT. DO NOT MIX HEAD TYPES OR MANUFACTURERS.

FLUSH MAIN SUPPLY LINES PRIOR TO THE INSTALLATION OF REMOTE CONTROL VALVES. FLUSH LATERAL LINES PRIOR TO THE INSTALLATION OF IRRIGATION HEADS OR EMITTERS.

IRRIGATION CONTROL WIRE SHALL BE #14 U.L. APPROVED FOR DIRECT BURIAL. COMMON WIRE TO BE WHITE IN COLOR. WIRES TO INDIVIDUAL CONTROL VALVES TO BE A COLOR OTHER THAN WHITE. SPLICES ARE TO BE MADE WITHIN A VALVE BOX USING A CRIMP TYPE COPPER WIRE CONNECTOR WITH A HEAT-SHRINK WATERPROOF JACKET. IN-LINE SPLICES SHALL BE SOLDERED. LEAVE 24" WIRE COILS AT EACH REMOTE CONTROL VALVE WIRE CONNECTION (TO ALLOW VALVE BONNET REMOVAL WITHOUT DISCONNECTING CONTROL WIRES.)

INSTALL REMOTE CONTROL VALVE BOXES ONE HALF INCH ABOVE GRADE. NOT NECESSARILY PLUMB. ALIGN VALVE BOXES WITH ADJACENT PAVEMENT EDGES OR STRUCTURES. VALVE BOXES TO BE PLASTIC WITH A BOLT DOWN LID.

VERIFY CONTROLLER LOCATION WITH OWNER. CONTRACTOR TO SUPPLY POWER TO CONTROLLER UNLESS OTHERWISE NOTED. EXCAVATIONS TO BE BACKFILLED TO 90% COMPACTION MINIMUM. CONTRACTOR TO REPAIR SETTLED TRENCHES FOR ONE YEAR AFTER COMPLETION OF WORK. CONTRACTOR SHALL WARRANT THAT THE SYSTEM WILL BE FREE FROM DEFECTS IN MATERIAL AND WORKMANSHIP FOR A PERIOD OF ONE YEAR AFTER COMPLETION OF WORK.

CONTRACTOR TO MAKE MINOR ADJUSTMENTS IN HEAD LOCATIONS AND ADJUST HEAD TYPE FOR RADIUS (AND ARC IF APPLICABLE) TO PROVIDE OPTIMUM COVERAGE AND TO MINIMIZE SPRAYING ONTO PAVEMENT, BUILDINGS OR STRUCTURES.

IRRIGATION LEGEND:

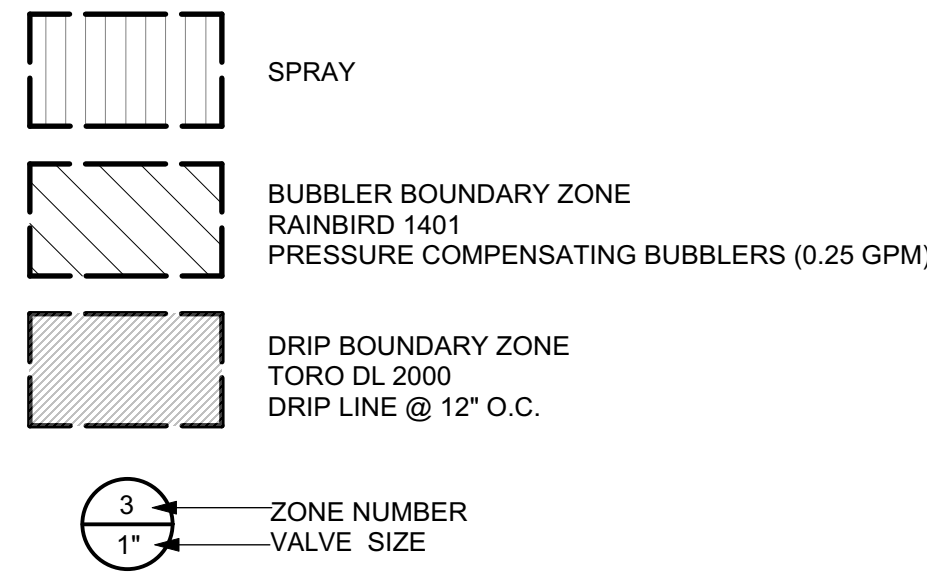

COMPONENT SCHEDULE:

- REDUCED PRESSURE BACKFLOW PREVENTER : 975XL2 WILKINS REDUCED PRESSURE BACKFLOW PREVENTER (LEAD FREE), W/ POLAR PARKA FOR FREEZE PROTECTION, VERIFY ENCLOSURE AND SIZE
  - PRESSURE REDUCING VALVE : 600XL, VERIFY SIZE, WILKINS PRESSURE REDUCING VALVE, SET DISCHARGE PRESSURE AT 50 PSI (LEAD FREE), VERIFY IF NEEDED
  - SUB METER : MJ75T-3/4" SEAMETRICS WATER METER
  - MASTER CONTROL VALVE : SUPERIOR NORMALLY CLOSED MASTER CONTROL VALVE
  - FLOW SENSOR : FSI-T10-001-1" / P7162D-A CREATIVE SENSOR TECHNOLOGY FLOW SENSOR WITH AIGE SHIELDED COMMUNICATION CABLE
  - FILTER : 1" COMPACT AMIAD FILTER W/ 155 MESH SCREEN, VERIFY SIZE
  - CONTROL VALVES : ICV-FS-AS-ADJ SERIES, HUNTER FILTER SENTRY PRESSURE ADJUSTABLE REMOTE CONTROL VALVE OR APPROVED EQUAL, VERIFY SIZE
  - GATE VALVES : T113-LF, NIBCO GATE VALVE (LEAD FREE), LINE SIZE
  - MAIN LINES : 1120-SCHEDULE 40 PVC PLASTIC PIPE WITH SCHEDULE 40 PVC SOLVENT-WELD FITTINGS, 18" COVER
  - BUBBLERS : TORO #53692 BUBBLER ON SWING T
  - LATERAL LINES FITTINGS, 12" COVER : 1120-SCHEDULE 40 PVC PLASTIC PIPE WITH SCHEDULE 40 PVC SOLVENT-WELD FITTINGS, 12" COVER
  - CONTROLLER : HUNTER I-CORE CONTROLLER (EXTERIOR WALL MOUNT) W/ WIRELESS SOLAR SYNC SENSOR, VERIFY LOCATION
  - HOSE BIB (NOT SHOWN) : CHAMPION HOSE BIB (LEAD FREE) WITH ANTI SIPHON / AVB VALVE (LEAD FREE)
  - IRRIGATION SLEEVING (NOT SHOWN) : 1120-SCHEDULE 40 PVC PLASTIC PIPE, 18" COVER, 24" UNDER VEHICULAR PAVING
- CONTRACTOR TO MAKE MINOR ADJUSTMENTS IN HEAD LOCATIONS AND ADJUST HEAD TYPE FOR RADIUS (AND ARC IF APPLICABLE) TO PROVIDE OPTIMUM COVERAGE AND TO MINIMIZE SPRAYING ONTO PAVEMENT, BUILDINGS OR STRUCTURES.
- GATE VALVES SHALL BE INSTALLED BEFORE EACH VALVE OR VALVE MANIFOLD.
- INSTALL A VALCON 5000 SERIES SPRING LOADED CHECK VALVE BELOW THOSE SPRINKLERS WHERE LOW HEAD DRAINAGE WILL CAUSE EROSION AND/OR EXCESS WATER.
- SUB-SURFACE IN-LINE DRIP FOR SHRUBS AND GROUND COVER**
- IN-LINE EMITTER TUBE BY 'NETAFIM', MODEL TECHLINE CV W/ CHECK VALVES, GRID LAYOUT, 0.4 GPH EMITTER FLOW, 12" EMITTER SPACING, 16" ROW SPACING, 4" BELOW GRADE. SECURE WITH 9" GALVANIZED JUTE MESH STAPLES, VERIFY IF NEEDED. INSTALL PER MANUFACTURER'S SPECIFICATIONS.
- EMITTER LINES TO RECEIVE IN-LINE FILTER MODEL #39-0 BY 'AMIAD' IN VALVE BOXES. USE PRESSURE REGULATORS AT PRESSURE ADJUSTABLE REMOTE CONTROL VALVES AT ALL DRIP STATIONS.
- EMITTER LINES TO BE ALG N ABOVE GRADE. SECURE TO FINISH GRADE WITH 9" GALVANIZED JUTE MESH STAPLES.
- FITTINGS AT EMITTER LINES TO BE COMPRESSION TYPE BY 'AGRICULTURAL PRODUCTS INC.'
- BUBBLERS FOR SHRUBS AND TREES**
- BUBBLERS FOR TREES TO BE MODEL 1401 (0.25 GPM, FLOOD) AND RWS-B-C-1401 (BUBBLER W/ DEEP WATERING BUBBLER ASSEMBLY (0.25 GPM, FLOOD) AND CHECK VALVE) FROM 'RAINBIRD'. OPERATE AT 35 PSI, USE PRESSURE REGULATOR AS REQUIRED

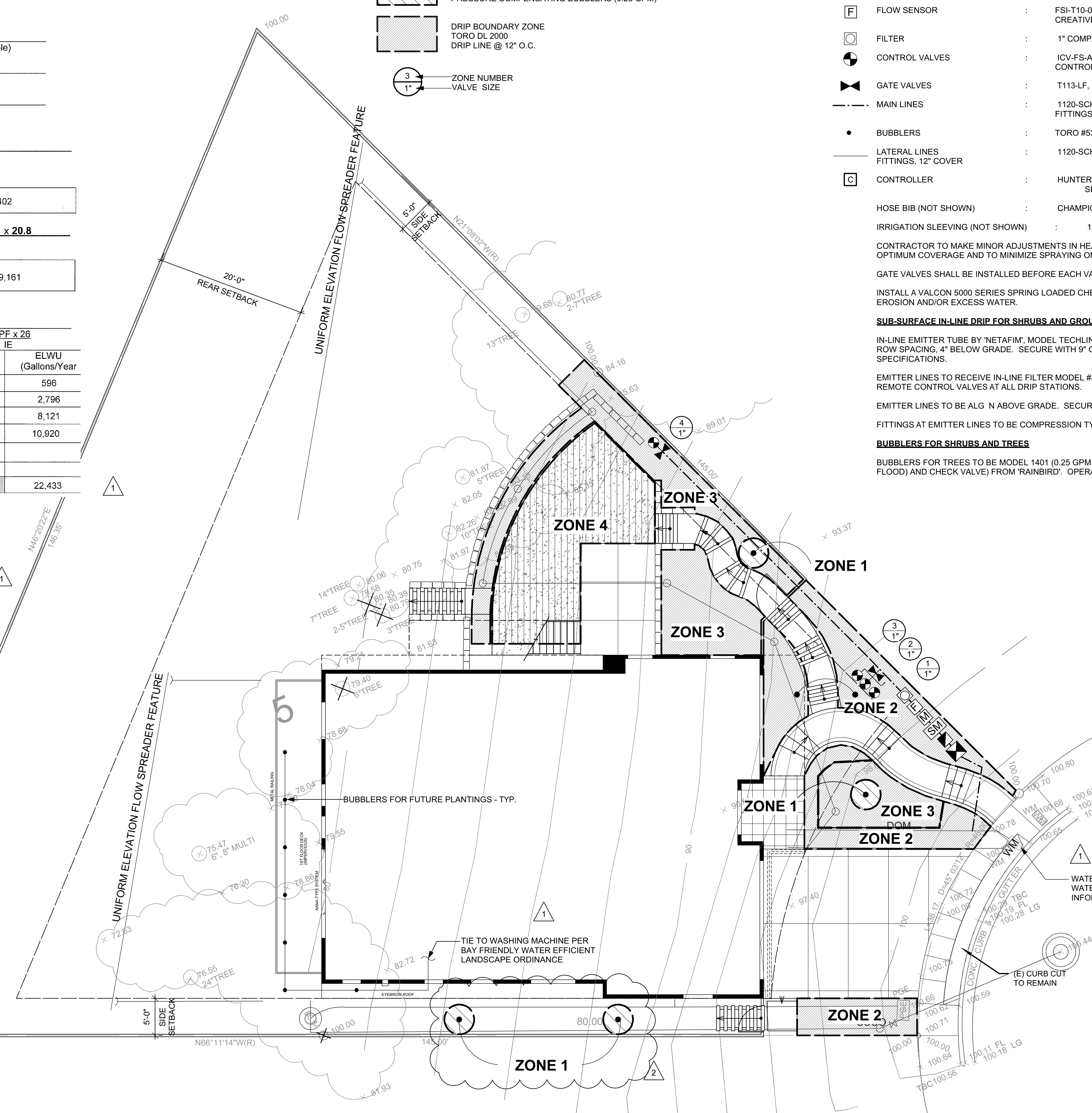

PRELIMINARY DRAWINGS ONLY - NOT FOR CONSTRUCTION

DATE	ISSUES & REVISIONS	NO.
05/31/18	DR RESUB.	3
02/14/18	DR RESUB.	2
08/15/17	DR SUB.	1



PROJECT# 1728 DRAWN BY: TK  
 ORIGINAL DRAWING SIZE: 24" X 36"  
 SCALE: 1/8" = 1' - 0"

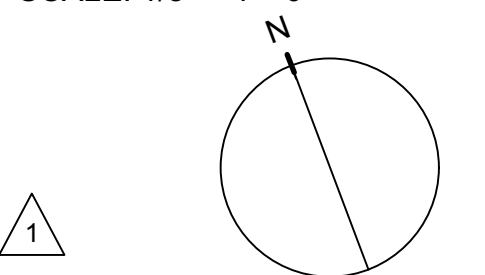

**IRRIGATION HYDROZONE PLAN**  
 SHEET #

**DD-3**

All written material appearing herein constitutes original unpublished work of the landscape architect and may not be duplicated, used or disclosed without the written consent of the landscape architect.

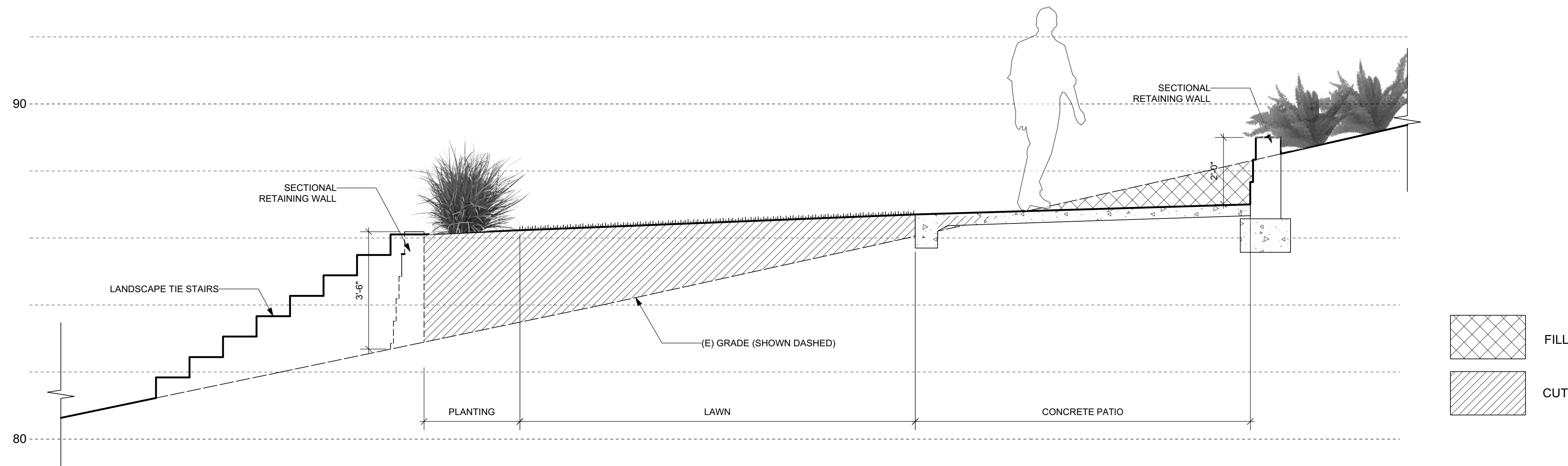

1 SECTION @ SIDEYARD  
Scale: 1/2" = 1'-0"

PRELIMINARY DRAWINGS ONLY - NOT FOR CONSTRUCTION

2	05/31/18	DR RESUB.	3
1	02/14/18	DR RESUB.	2
	08/15/17	DR SUB.	1

DATE	ISSUES & REVISIONS	NO.
------	--------------------	-----



PROJECT# 1728 DRAWN BY: TK  
 ORIGINAL DRAWING SIZE: 24" X 36"

**SECTION**  
 SHEET #  
**DD-4**

All written material appearing herein constitutes original unpublished work of the landscape architect and may not be duplicated, used or disclosed without the written consent of the landscape architect.



# 2367 RAINBOW COURT

CITY OF HAYWARD, ALAMEDA COUNTY, CALIFORNIA

## GENERAL NOTES:

1. THE ENGINEER ASSUMES NO RESPONSIBILITY BEYOND THE ADEQUACY OF THIS DESIGN CONTAINED HEREIN.
2. THE CONSTRUCTION CONTRACTOR AGREES, THAT IN ACCORDANCE WITH GENERALLY ACCEPTED CONSTRUCTION PRACTICES, TO ASSUME SOLE AND COMPLETE RESPONSIBILITY FOR JOB SITE CONDITIONS DURING THE COURSE OF CONSTRUCTION OF THE PROJECT, INCLUDING SAFETY OF ALL PERSONS AND PROPERTY; THAT THIS REQUIREMENT SHALL BE MADE TO APPLY CONTINUOUSLY AND NOT BE LIMITED TO NORMAL WORKING HOURS; AND THE CONSTRUCTION CONTRACTOR FURTHER AGREES TO DEFEND, INDEMNIFY AND HOLD THE DESIGN PROFESSIONAL HARMLESS FROM ANY AND ALL LIABILITY, REAL OR ALLEGED, IN CONNECTION WITH THE PERFORMANCE OF WORK ON THIS PROJECT, EXCEPTING LIABILITY ARISING FROM THE SOLE NEGLIGENCE OF THE DESIGN PROFESSIONAL.
3. EXCAVATIONS SHALL BE ADEQUATELY SHORED, BRACED AND SHEETED SO THAT ALL EXISTING IMPROVEMENTS OF ANY KIND WILL BE FULLY PROTECTED FROM DAMAGED. ANY DAMAGE RESULTING FROM A LACK OF ADEQUATE SHORING, BRACING AND SHEETING, SHALL BE THE RESPONSIBILITY OF THE CONTRACTOR AND HE SHALL EFFECT NECESSARY REPAIRS OR RECONSTRUCTION AT HIS OWN EXPENSE. EXCAVATION SHEETING AND BRACING SHALL CONFORM TO THE APPLICABLE CONSTRUCTION SAFETY ORDERS OF THE DIVISION OF INDUSTRIAL SAFETY OF THE STATE OF CALIFORNIA. THE CONTRACTOR SHALL ALWAYS COMPLY WITH OSHA REQUIREMENTS.
4. OBSTRUCTIONS INDICATED ARE FOR INFORMATION ONLY. IT IS THE CONTRACTOR'S RESPONSIBILITY TO VERIFY THE LOCATION AND DEPTH WITH THE APPROPRIATE AGENCIES. NEITHER THE OWNER NOR THE ENGINEER ASSUMES RESPONSIBILITY THAT THE OBSTRUCTIONS INDICATED WILL BE THE OBSTRUCTION ENCOUNTERED.
5. THE EXISTENCE AND LOCATION OF ANY UNDERGROUND UTILITIES, PIPES AND/OR STRUCTURES SHOWN ON THIS SURVEY WERE OBTAINED BY A SEARCH OF AVAILABLE RECORDS. THE CONTRACTOR SHALL NOTIFY UNDERGROUND SERVICE ALERT (800-642-2444) FOR UTILITY LOCATIONS 48 HOURS PRIOR TO POTHOLE OR EXCAVATION. THE U.S.A. NUMBER SHALL BE KEPT ON THE JOB SITE. THE CONTRACTOR SHALL ASCERTAIN THE TRUE LOCATION, SIZE, AND DEPTH OF ANY UNDERGROUND UTILITIES PRIOR TO ANY CONSTRUCTION, AND SHALL BE RESPONSIBLE FOR DAMAGE TO ANY PUBLIC OR PRIVATE UTILITIES, SHOWN OR NOT SHOWN HEREON. CONTRACTOR MAY HAVE TO RELOCATE EXISTING UTILITIES OR FIELD ADJUST PROPOSED IMPROVEMENT AS REQUIRED. CONTRACTOR SHALL NOTIFY THE ENGINEER AT (510) 724-3388 PRIOR TO CONTINUING THE CONSTRUCTION. THE CONTRACTOR IS RESPONSIBLE FOR COORDINATION WITH ALL NECESSARY UTILITY COMPANIES FOR ANY RELOCATION OF THEIR FACILITIES.
6. THE CONTRACTOR SHALL EXPOSE AND CHECK INVERTS ON EXISTING STORM DRAIN, SEWER, WATER MAIN, JOINT TRENCHES AND CLEARANCES OF KNOWN CROSSINGS OR OTHER UTILITIES BEFORE CONSTRUCTING NEW PIPELINES.
7. THE CONTRACTOR IS RESPONSIBLE FOR MATCHING EXISTING STREETS, SURROUNDING LANDSCAPE AND OTHER IMPROVEMENTS WITH A SMOOTH TRANSITION IN PAVING, CURBS, GUTTERS, SIDEWALKS, GRADING, ETC., AND TO AVOID ANY ABRUPT OR APPARENT CHANGES IN GRADES OR CROSS SLOPES, LOW SPOTS OR HAZARDOUS CONDITIONS.
8. THE ENGINEER ASSUMES NO RESPONSIBILITY FOR FINAL GRADE OF CONCRETE UNLESS FORMS ARE CHECKED BY THE ENGINEER PRIOR TO POURING. ANY CHECKING OF THE FORMS BY THE ENGINEERS SHALL BE AT THE OWNER'S EXPENSE.
9. THE CONTRACTOR SHALL POST EMERGENCY TELEPHONE NUMBERS FOR PUBLIC WORKS, AMBULANCE, POLICE AND FIRE DEPARTMENTS AT THE JOB SITE.
10. THE CONTRACTOR SHALL PROVIDE, AT ALL TIMES, LIGHTS, SIGNS, BARRICADES, FLAGMEN OR OTHER DEVICES NECESSARY TO PROVIDE FOR PUBLIC SAFETY PER MUTCD TRAFFIC CONTROL SPECIFICATIONS LATEST EDITION. IT IS THE RESPONSIBILITY OF THE CONTRACTOR TO MAINTAIN PROPER TRAFFIC CONTROL AT ALL TIMES.
11. THE CONTRACTOR SHALL PROVIDE FOR INGRESS AND EGRESS FOR PRIVATE PROPERTY ADJACENT TO THE SITE THROUGHOUT THE PERIOD OF CONSTRUCTION.
12. PRIOR TO COMMENCEMENT OF ANY WORK ON ADJACENT PROPERTIES, THE OWNER SHALL OBTAIN WRITTEN PERMISSION FROM AFFECTED PROPERTY OWNERS.
13. CONSTRUCTION OPERATIONS SHALL BE LIMITED TO WEEKDAYS (MONDAY THROUGH FRIDAY, EXCEPT CITY HOLIDAYS) AND THE HOURS FROM 7:00 A.M. TO 7:00 P.M. UNLESS OTHERWISE APPROVED IN WRITING BY THE CITY ENGINEER.
14. ALL MATERIALS AND WORKMANSHIP SHALL BE IN CONFORMANCE WITH THE STANDARD SPECIFICATIONS, STANDARD DRAWINGS, AND REQUIREMENTS OF THE CITY OF HAYWARD.
15. SHOULD IT APPEAR THAT THE WORK TO BE DONE, OR ANY MATTER RELATIVE THERETO, IS NOT SUFFICIENTLY DETAILED OR EXPLAINED ON THESE PLANS, THE CONTRACTOR SHALL CONTACT LUK AND ASSOCIATES AT (510) 724-3388 FOR SUCH FURTHER EXPLANATIONS AS MAY BE NECESSARY.
16. THE CONTRACTOR SHALL PROVIDE THE NECESSARY SAFETY TESTING OF EQUIPMENT AND PERSONNEL.

17. PRIOR TO PLACING CURB, SIDEWALK, ASPHALT CONCRETE, SUBBASE, OR BASE MATERIAL, ALL UNDERGROUND UTILITIES WITHIN THE PAVED AREAS SHALL BE INSTALLED, BACKFILL COMPLETED, TESTED AND APPROVED FOR SUCH UTILITY INSTALLATION.
18. IF ARCHAEOLOGIC MATERIALS ARE UNCOVERED DURING GRADING, TRENCHING, OR OTHER EXCAVATION, EARTHWORK WITHIN 100 FEET OF THESE MATERIALS SHALL BE STOPPED UNTIL A PROFESSIONAL ARCHAEOLOGIST WHO IS CERTIFIED BY THE SOCIETY OF CALIFORNIA ARCHAEOLOGY (SPA) AND/OR THE SOCIETY OF PROFESSIONAL ARCHAEOLOGY (SOPA) HAS HAD AN OPPORTUNITY TO EVALUATE THE SIGNIFICANCE OF THE FIND AND SUGGEST APPROPRIATE MITIGATION MEASURES IF THEY DEEMED NECESSARY. ANY COSTS ASSOCIATED WITH ARCHAEOLOGICAL INVESTIGATION, TESTING, STOPPING WORK, ETC. SHALL BE PAID FOR BY THE OWNER.
19. EXISTING CURB AND SIDEWALK, WITHIN THE PROJECT LIMITS THAT ARE DAMAGED OR DISPLACED DURING THE CONSTRUCTION PERIOD SHALL BE REPAIRED OR REPLACED, AT THE CONTRACTOR'S EXPENSE AS DETERMINED BY THE CITY ENGINEER.
20. ALL IMPROVEMENTS SHALL BE CONSTRUCTED IN ACCORDANCE WITH CITY OF HAYWARD STANDARD SPECIFICATIONS AND DETAILS SUBJECT TO THE INSPECTION AND APPROVAL OF THE ENGINEERING DIVISION. ALL REVISIONS MUST BE APPROVED BY THE CITY PRIOR TO CONSTRUCTION.
21. ALL STORM DRAIN STRUCTURES GREATER THAN 4' IN DEPTH SHALL HAVE STEPS INSTALLED PER THE LATEST FEDERAL AND STATE SAFETY STANDARDS. A CONCRETE COVER SLAB SHALL BE INSTALLED OVER PIPE WITH LESS THAN 1' OF COVER UNLESS OTHERWISE SPECIFIED ON THE PLAN. ALL STORM DRAIN PIPES ARE AS INDICATED ON THESE PLANS.
22. MUD TRACKED ONTO STREETS OR ADJACENT PROPERTIES SHALL BE REMOVED IMMEDIATELY. STREETS SHALL BE WASHED OR SWEEP AS DIRECTED BY THE CITY INSPECTOR.
23. TREES TO BE SAVED SHALL BE FLAGGED AND MARKED PRIOR TO ANY CLEARING OR STRIPPING WORK AND PROTECTIVE FENCING, WHERE REQUIRED BY THE CITY, SHALL BE INSTALLED PRIOR TO COMMENCING ANY GRADING. LOCATIONS OF FENCING SHALL BE APPROVED IN THE FIELD BY THE CITY UPON COMPLETION OF THE STAKING OF DAYLIGHT LINES.
24. GRADING OR ANY OTHER OPERATION THAT CREATES DUST SHALL BE STOPPED IMMEDIATELY IF DUST AFFECTS ADJACENT PROPERTIES. SUFFICIENT WATERING TO CONTROL DUST AT ALL TIMES AND A DUST PALLIATIVE MAY BE REQUIRED BY THE CITY ENGINEER.
25. PROJECTS PROPOSED FOR CONSTRUCTION BETWEEN OCTOBER 15TH AND APRIL 15TH MUST HAVE AN EROSION AND SEDIMENTATION CONTROL PROGRAM APPROVED, AND IMPLEMENTED PRIOR TO THE START OF ON-SITE EARTHWORK. EARTHWORK THAT IS NECESSARY TO INSTALL EROSION AND SEDIMENTATION CONTROL FACILITIES, SUCH AS DRAINAGE DITCHES AND SEDIMENTATION BASINS, MAY PROCEED CONCURRENT WITH THE INSTALLATION OF THE EROSION CONTROL FACILITIES. OWNER SHALL PAY THE COSTS OF PREPARING ANY SWPPP. CONTRACTOR HAS INCLUDED FUNDS FOR THE COSTS OF INSTALLING THE SWPPP WORK SHOWN ON THE PLANS. IF ADDITIONAL WORK BEYOND WHAT IS SHOWN ON THE PLANS IS REQUIRED IT SHALL BE ADDED TO THE CONTRACT. OWNER SHALL TIMELY PAY FOR AND OBTAIN ANY STORM WATER DISCHARGE PERMITS, INCLUDING PERMITS THAT MAY BE NEEDED FROM EAST BAY MUNICIPAL UTILITY DISTRICT, THAT MAY BE REQUIRED TO HANDLE SITE WATER ARISING FROM THE CONSTRUCTION OF THE WORK.
26. CONTRACTOR SHALL ADJUST ALL EXISTING UTILITIES TO GRADE AFFECTED BY CONSTRUCTION.
27. THE CONTRACTOR SHALL COMPLY WITH ALL RULES, REGULATIONS AND PROCEDURES OF THE NATIONAL POLLUTANT DISCHARGE ELIMINATION SYSTEM (NPDES) FOR MUNICIPAL CONSTRUCTION AND INDUSTRIAL ACTIVITIES AS PROMULGATED BY THE CALIFORNIA STATE WATER RESOURCE CONTROL BOARD OR ANY OF ITS REGIONAL WATER QUALITY CONTROL BOARDS.
28. ALL CURBS SHALL BE STAKED BY A REGISTERED CIVIL ENGINEER OR A LICENSED LAND SURVEYOR.
29. ANY ENCROACHMENT PERMITS SHALL BE PAID FOR BY THE OWNER AND OBTAINED BY CONTRACTOR IN A TIMELY MANNER SO AS TO AVOID DELAY TO THE CONSTRUCTION SCHEDULE.
30. ALL EXISTING ELEVATIONS SHOWN ARE AS MEASURED IN THE FIELD UNLESS OTHERWISE NOTED.
31. IT IS THE CONTRACTOR'S LIABILITY TO REPLACE ALL STREET MONUMENTS, LOT CORNER PIPES, AND GRADE STAKES DISTURBED DURING THE PROCESS OF CONSTRUCTION AT THE REGULAR ENGINEER'S FEE.
32. THE CITY ASSUMES NO RESPONSIBILITY FOR THE ACCURACY OR COMPLETENESS OF THESE PLANS. THE OWNER/DEVELOPER IS RESPONSIBLE FOR THE CORRECTION OF ERRORS OR OMISSIONS ON THE PLANS.
33. CONSTRUCTION OF IMPROVEMENTS SHALL BE UNDER THE RESPONSIBLE DIRECTION OF THE OWNER'S/DEVELOPER'S ENGINEER.
34. RIGHT-OF-ENTRY IS GRANTED TO THE CITY OFFICIAL FOR ACCESS TO THE JOB SITE.
35. SEE DUST MITIGATION NOTES ON THIS SHEET.

36. THE CONTRACTOR IS RESPONSIBLE FOR COORDINATING HIS WORK TO AVOID CONFLICTS BETWEEN SEWER LATERALS, STORM DRAIN LINES, WATER MAINS, GAS LINES, AND OTHER UTILITIES.
37. WHERE EXISTING PAVEMENT IS TO BE EXTENDED, EXISTING PAVEMENT ENDS MUST BE SAW-CUT AT THE CONFORM. ANY A.C. OR P.C.C. PAVEMENT REMOVED MUST BE SAWCUT OR REMOVED TO AN EXPANSION JOINT.
38. CONTRACTOR SHALL MAINTAIN SITE NEAT AND FREE OF TRASH, RUBBISH, AND OTHER DEBRIS. UPON COMPLETION OF WORK, CONTRACTOR SHALL REMOVE ALL EXCESS EXCAVATED MATERIALS FROM SITE.
39. THE CONTRACTOR SHALL PROPERLY COORDINATE HIS WORK WITH THE WORK UNDER OTHER CONTRACTS THAT MAY BE UNDERWAY CONCURRENTLY WITH THIS PROJECT.
40. NO WORK SHALL BE PERFORMED WITHOUT INSPECTION BY THE CITY. IF ANY WORK THAT REQUIRES INSPECTION MUST BE PERFORMED OUTSIDE OF NORMAL WORKING HOURS, CONTRACTOR SHALL SUBMIT A WRITTEN REQUEST FOR INSPECTION SERVICES TO THE CITY ENGINEER 24 HOURS IN ADVANCE OF THE TIME SUCH SERVICES WILL BE REQUIRED.
41. FOR DETAILS NOT SHOWN ON THESE PLANS, REFER TO CITY OF HAYWARD STANDARD SPECIFICATIONS AND CONSTRUCTION DETAILS AVAILABLE AT THE CITY.
42. THE CONTRACTOR SHALL ARRANGE A PRE-CONSTRUCTION MEETING WITH THE CITY ENGINEER OR HIS DESIGNATED REPRESENTATIVE, THE OWNER OR THE OWNER'S REPRESENTATIVE, AND THE OWNER'S CIVIL AND SOILS ENGINEER(S), AND OTHER CONSULTANTS INVOLVED PRIOR TO START OF CONSTRUCTION.
43. THE CONTRACTOR SHALL VERIFY LOCATION OF EXISTING UTILITIES WITHIN AREAS OF IMPROVEMENT AND CONDUCT ALL CONSTRUCTION OPERATIONS IN SUCH A MANNER THAT THE EXISTING UTILITIES ARE NOT DAMAGED WHATSOEVER.
44. CONTRACTOR'S ATTENTION IS DIRECTED TO THE REQUIREMENTS OF THE DIVISION OF INDUSTRIAL SAFETY PERTAINING TO "CONFINED SPACES". MANHOLES, CULVERT, DROP INLET OR TRENCH WHICH COULD CONTAIN AIR WHICH IS NOT READILY VENTILATED MAY BE CONSIDERED A "CONFINED SPACE".
45. RIGHT-OF-ENTRY IS GRANTED TO THE CITY OFFICIAL FOR ACCESS TO THE JOB SITE.
46. ALL REVISIONS TO THESE PLANS MUST BE APPROVED BY THE CITY OF HAYWARD ENGINEERING DIVISION PRIOR TO CONSTRUCTION AND SHALL BE ACCURATELY SHOWN ON REVISED PLANS STAMPED AND DISTRIBUTED BY THE ENGINEERING DIVISION PRIOR TO ACCEPTANCE OF THE WORK AS COMPLETED.
47. CONSTRUCTION ZONE TRAFFIC CONTROLS SHALL CONFORM TO THE LATEST REVISION OF THE MANUAL OF TRAFFIC CONTROLS FOR CONSTRUCTION AND MAINTENANCE WORK ZONES BY THE CALIFORNIA DEPARTMENT OF TRANSPORTATION.
48. CONTRACTOR SHALL EFFECT AND MAINTAIN PRECAUTIONARY MEASURES TO PROTECT ADJACENT WATERCOURSES AND PUBLIC OR PRIVATE PROPERTY FROM DAMAGE BY EROSION, FLOODING, AND DEPOSITION OF MUD OR DEBRIS ORIGINATING FROM THE SITE.
49. RAISE MANHOLES, VALVES, ETC., TO GRADE AFTER PAVING HAS BEEN ACCOMPLISHED. IF PAVING JOB IS LAID IN TWO LIFTS, RAISE TO GRADE BETWEEN FIRST AND SECOND LIFT.

## CONSTRUCTION DUST MITIGATIONS:

1. THROUGHOUT CONSTRUCTION PERIOD THE CONTRACTOR SHALL:
2. WATER ALL ACTIVE CONSTRUCTION AREAS AT LEAST TWICE DAILY.
3. WATERING OR COVERING OF STOCKPILES OF DEBRIS, SOIL, SAND OR OTHER MATERIALS THAT CAN BE BLOWN BY THE WIND.
4. COVER ALL TRUCKS HAULING SOIL, SAND, AND OTHER LOOSE MATERIALS.
5. SWEEP DAILY (PREFERABLY WITH WATER SWEEPERS) ALL PAVED ACCESS ROAD, PARKING AREAS AND STAGING AREAS AT CONSTRUCTION SITES.
6. SWEEP STREETS DAILY (PREFERABLY WITH WATER SWEEPERS) IF VISIBLE SOIL MATERIAL IS CARRIED ONTO ADJACENT PUBLIC STREETS.
7. DURING DEMOLITION, THE CONTRACTOR SHALL: DUST-PROOF CHUTES SHOULD BE USED FOR LOADING CONSTRUCTION DEBRIS ONTO TRUCKS.
8. WATERING SHOULD BE USED TO CONTROL DUST GENERATION DURING DEMOLITION OR STRUCTURES AND BREAKUP OF PAVEMENT.
9. COVER ALL TRUCKS HAULING DEMOLITION DEBRIS FROM THE SITE.

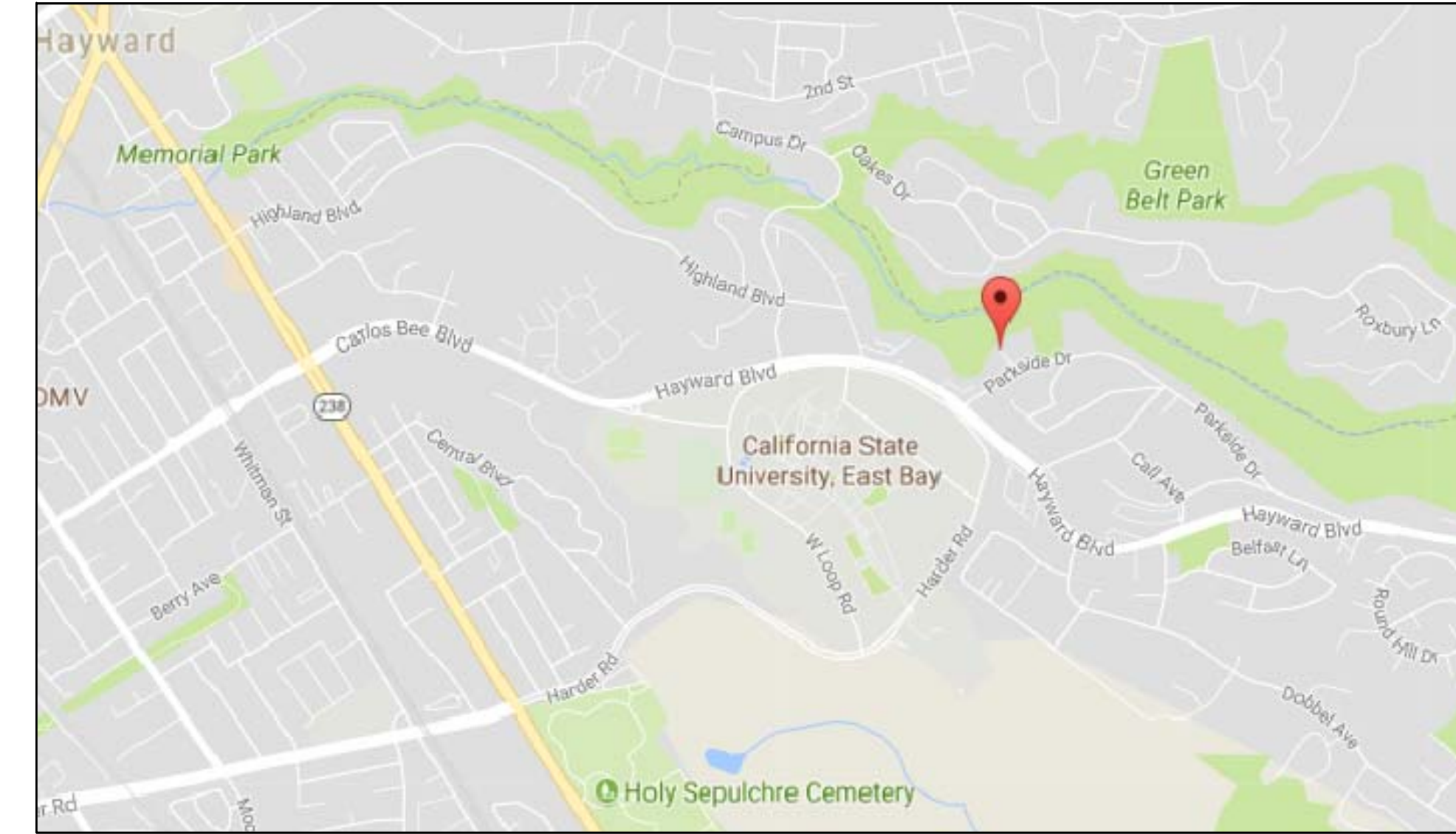

## SHEET INDEX

SHEET NO.	DESCRIPTION
C-1	GENERAL NOTES
C-2	DETAILS
C-3	GRADING PLAN: ELEVATIONS
C-4	UTILITY PLAN
C-5	EROSION CONTROL PLAN

## LEGEND

### ABBREVIATIONS

AB	AGGREGATE BASE
AC	ASPHALTIC CONCRETE
BW	BACK OF WALK
BLDG	BUILDING
CB	CATCH BASIN
CO	CLEAN OUT
CONC	CONCRETE
DI	DRAIN INLET
DWY	DRIVEWAY
EB	ELECTRICAL BOX
ELE	ELEVATION
EX	EXISTING
FC	FACE OF CURB
FF	FINISHED FLOOR ELEVATION
FL	FLOW LINE
G	GAS
GB	GRADE BREAK
GM	GAS METER
GP	GALVANIZED PIPE(BOLLARD)
GRD	GROUND ELEVATION
GR	GRATE ELEVATION
HC	HANDICAP PARKING
HP	HIGH POINT
IRRI	IRRIGATION
JP	JOINT POLE
LF	LINEAR FOOT
LP	LOW POINT
MIN	MINIMUM
MAX	MAXIMUM
PAD	PAD ELEVATION
PAV	PAVEMENT
PG&E	PACIFIC GAS & ELECTRIC
PVC	POLYVINYL CHLORIDE PLASTIC PIPE
R/W	RIGHT OF WAY
RCP	REINFORCED CONCRETE PIPE
S	SLOPE
SD	STORM DRAIN
SDMH	STORM DRAIN MANHOLE
SS	SANITARY SEWER
SSCO	SANITARY SEWER CLEAN OUT
SSMH	SANITARY SEWER MANHOLE
T	TRANSITION
TC	TOP OF CURB
TP	TOP OF PAVING
(T)	TOTAL
(TYP)	TYPICAL
W	WATER
WM	WATER METER
WV	WATER VALVE

### SYMBOL

#### EXISTING      PROPOSED

SYMBOL	DESCRIPTION
—	BOUNDARY LINE
—	BUILDING LINE
—	WATERLINE
—	JOINT TRENCH
—	GAS LINE
—	SANITARY SEWER LINE
—	MANHOLE OR CLEANOUT
□	CATCH BASIN, MANHOLE
—	DIRECTION OF STORMWATER RUNOFF
—	STORM DRAIN LINE
⊙	FOUND STANDARD CITY MONUMENT
⊙	FIRE HYDRANT (FH), WATER VALVE (WV)
□	WATER METER
⊙	ROOF DOWN DRAIN, DOWN SPOUT
×	CONCRETE ELEVATION
×	GROUND ELEVATION
×	TOP OF PAVING ELEVATION
×	TOP OF CURB
×	LIP OF GUTTER
×	6" VERTICAL CURB
—	CONCRETE CURB AND GUTTER
×	BOTTOM OF WALL
×	SIDEWALK ELEVATION
×	GRADE BREAK LINE
25	CONSTRUCTION NOTES
+	TRAFFIC SIGN
⊙	JOINT POLE
⊙	ELECTROLIER

## Luk and Associates

Civil Engineering  
Land Planning  
Land Surveying  
738 Alfred Nobel Drive  
Hercules, CA 94547  
Phone (510) 724-3388  
Fax (510) 724-3383

Seal:



2367 RAINBOW CT.  
HAYWARD, CA

REVISIONS	DATE
Permit Set	2/14/2018

Date: 2/14/2018  
Scale: AS NOTED  
Job No.: 17160A10  
Dwg: MASTER-17160A10  
Title:  
**COVER SHEET**

Sheet No.:

**C-1**

Plot Date:

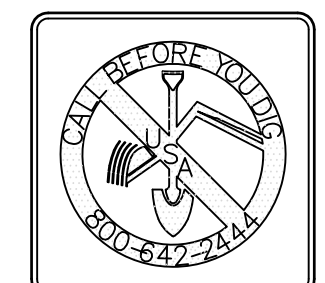

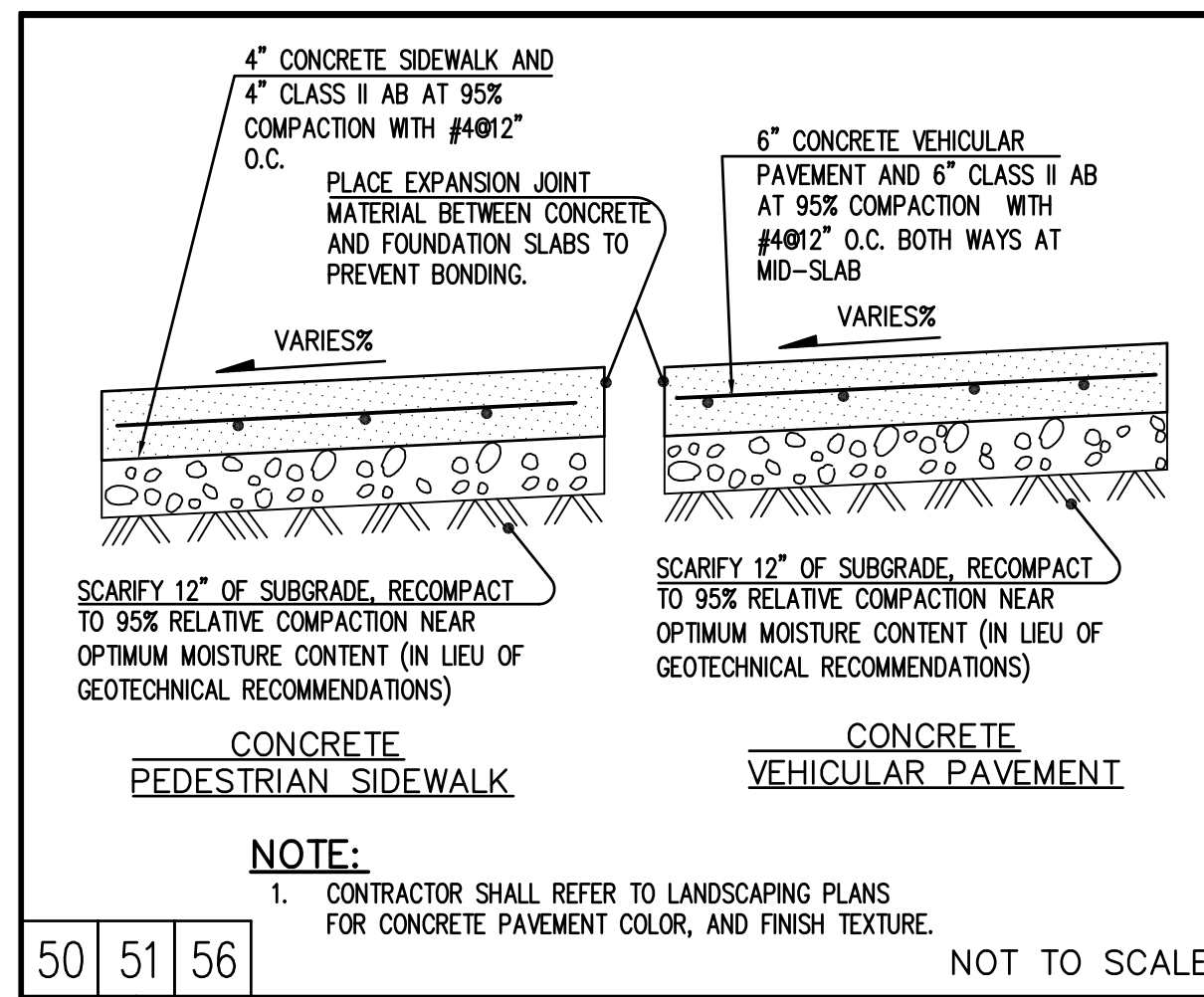

50 51 56 1 CONCRETE PAVEMENT DETAILS

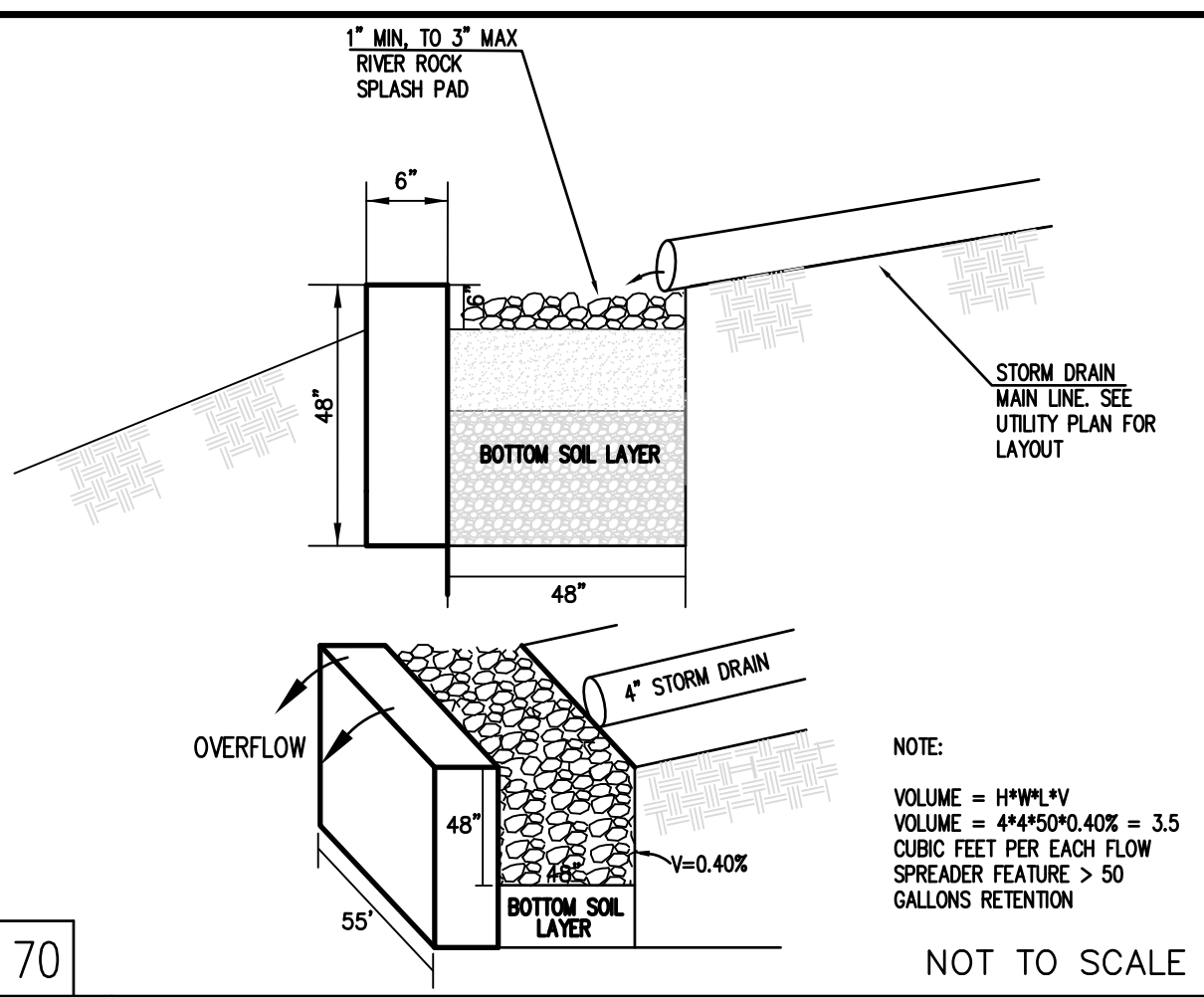

70 5 FLOW SPREADER DETAIL

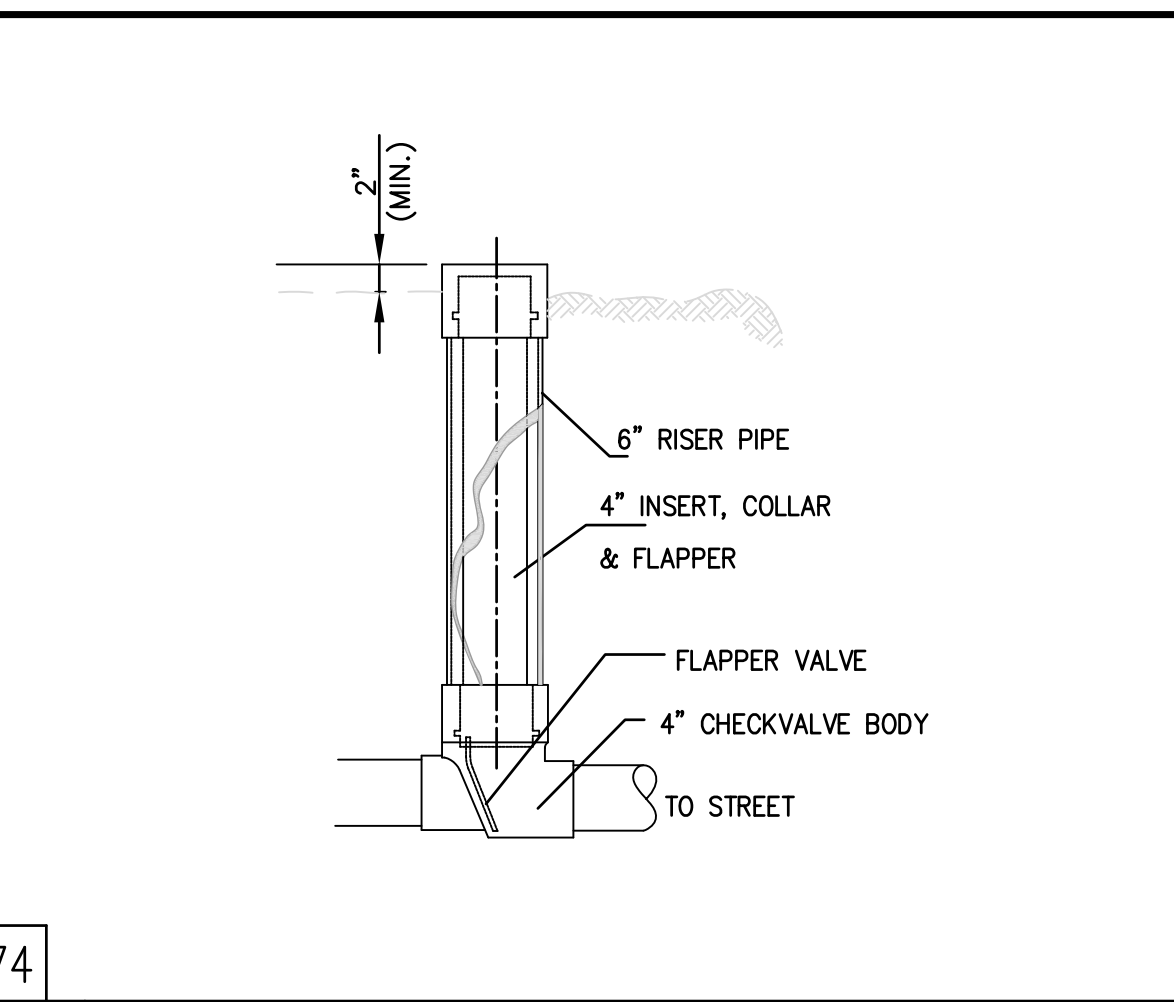

74 10 CHECK VALVE DETAIL

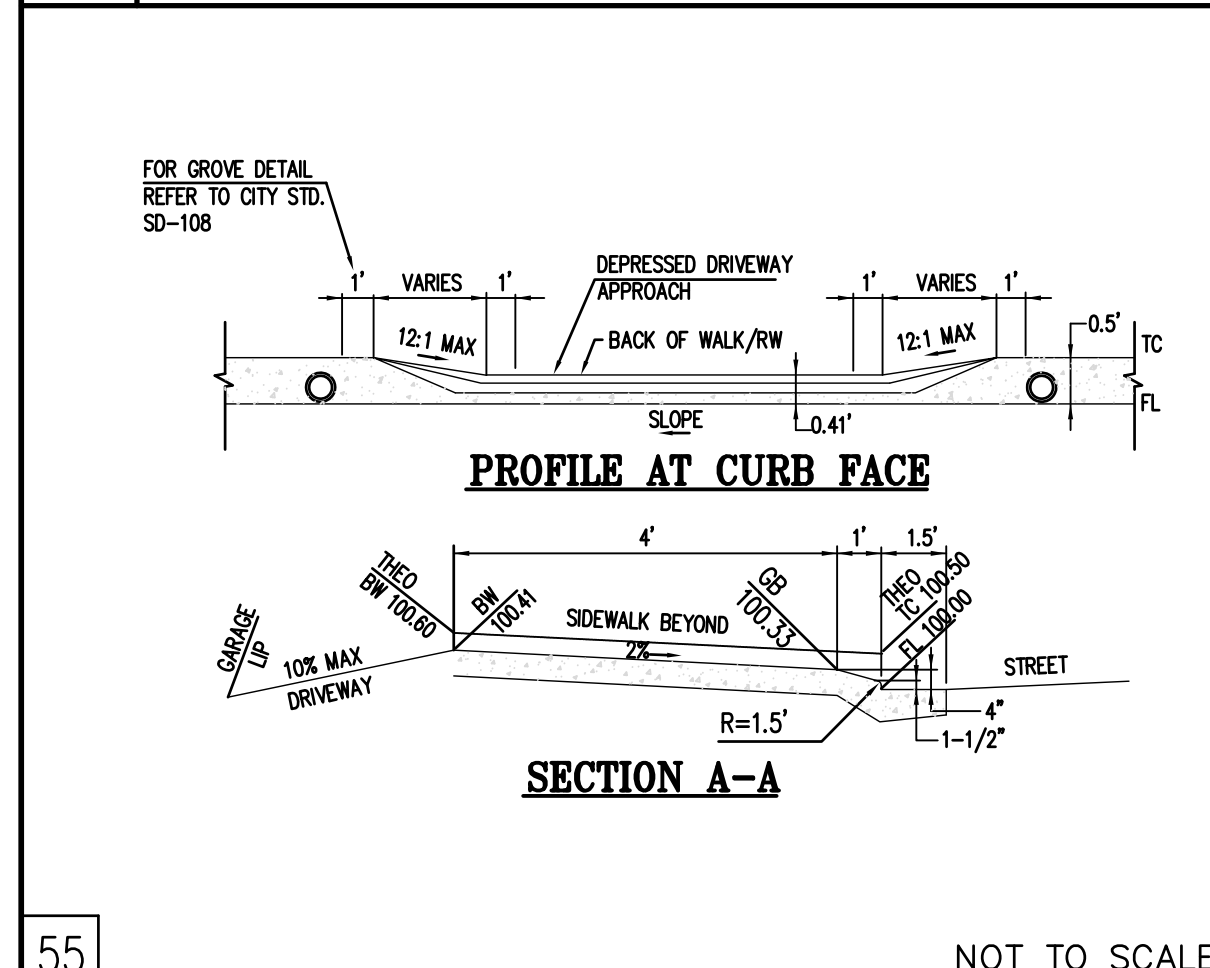

55 2 DRIVEWAY DETAIL

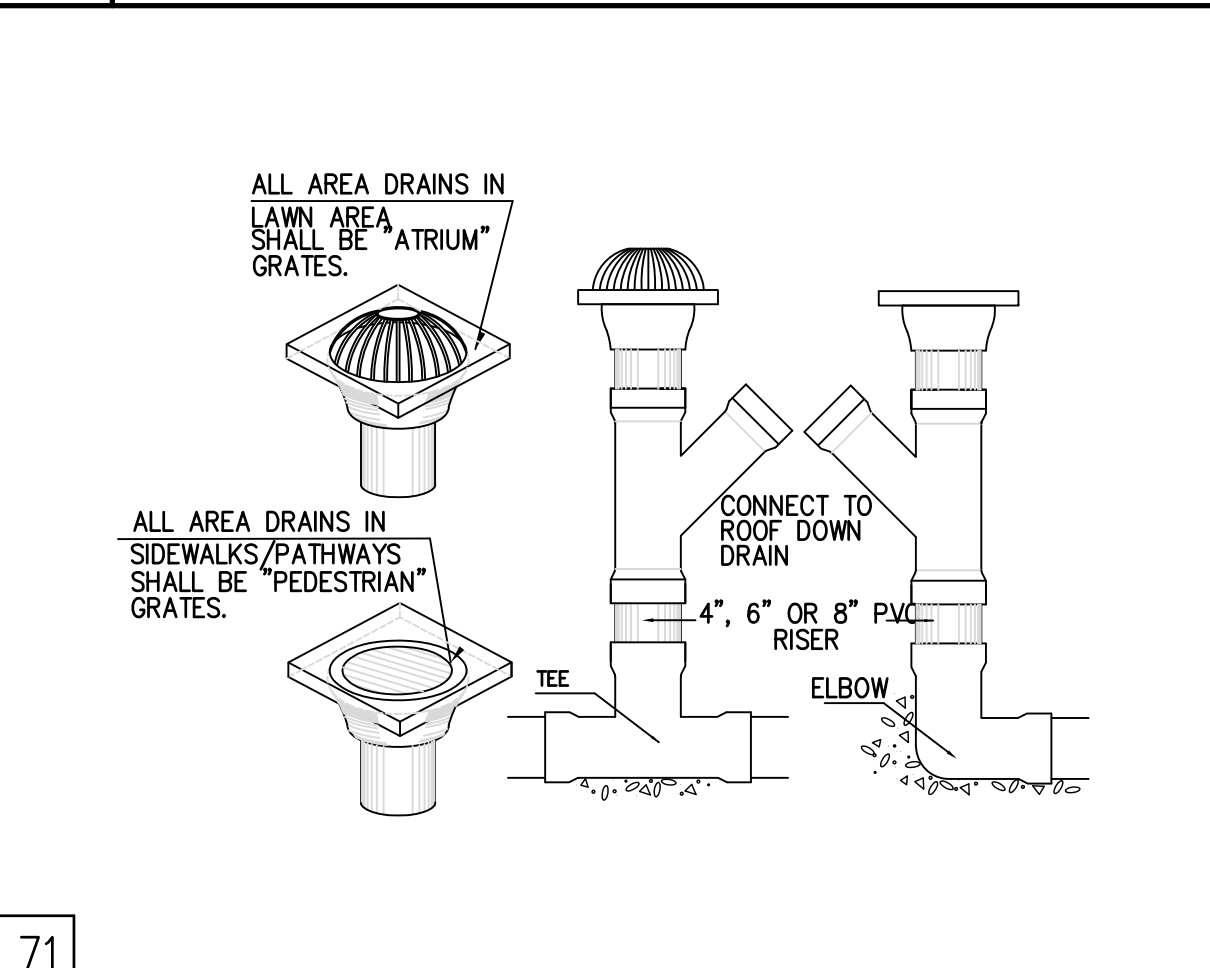

71 7 AREA DRAIN DETAIL

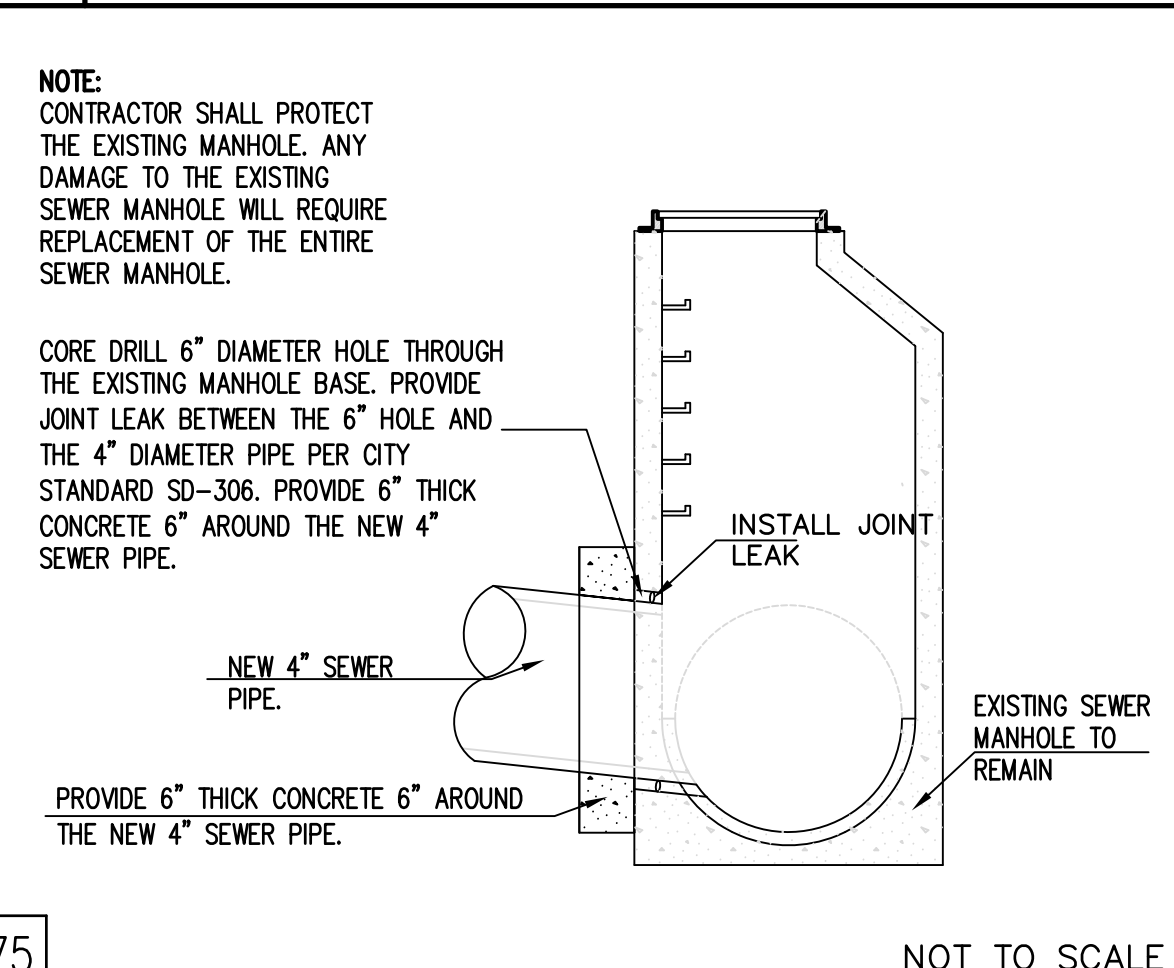

75 11 NEW PIPE TO MANHOLE DETAIL

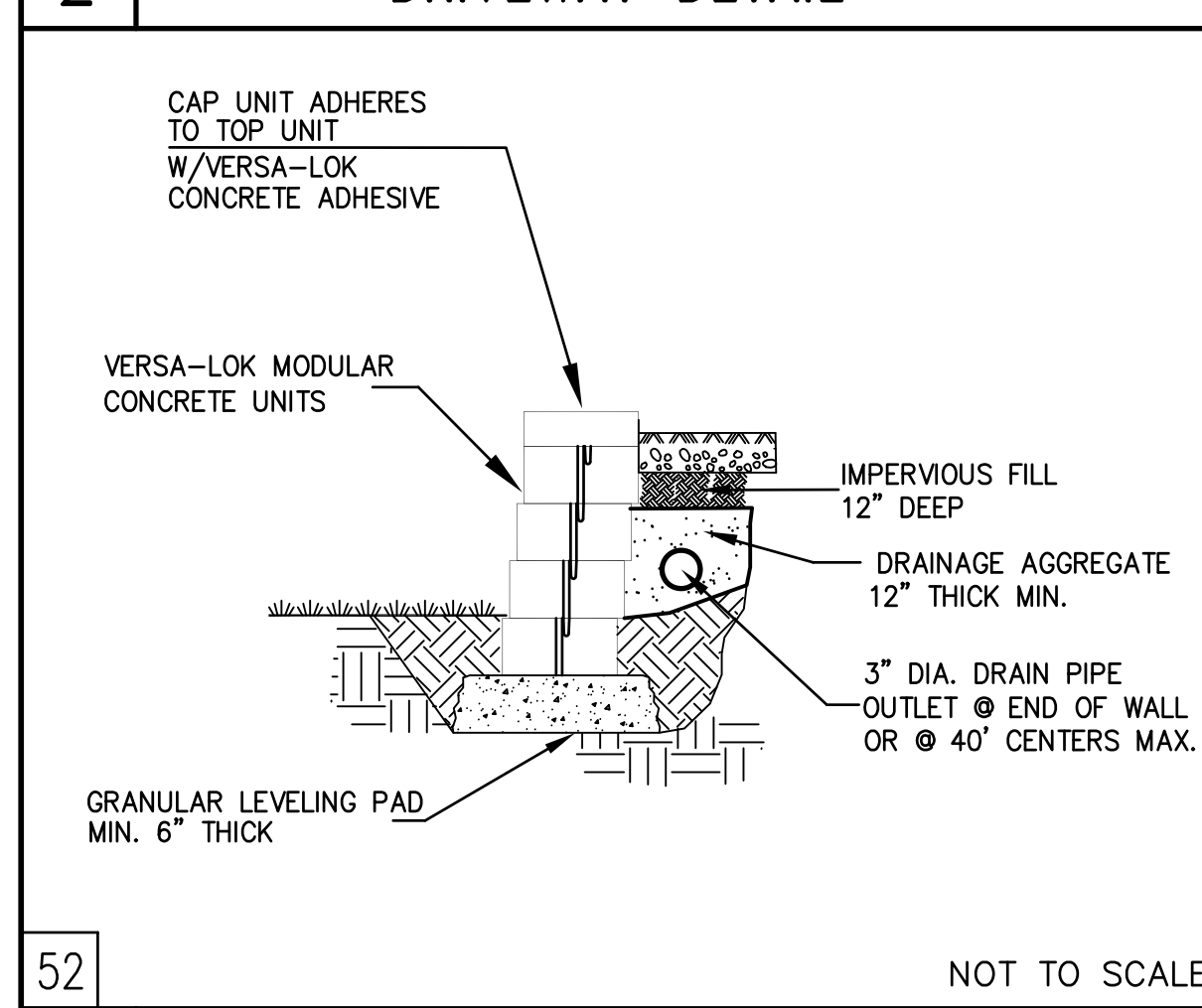

52 3 RETAINING WALL DETAIL

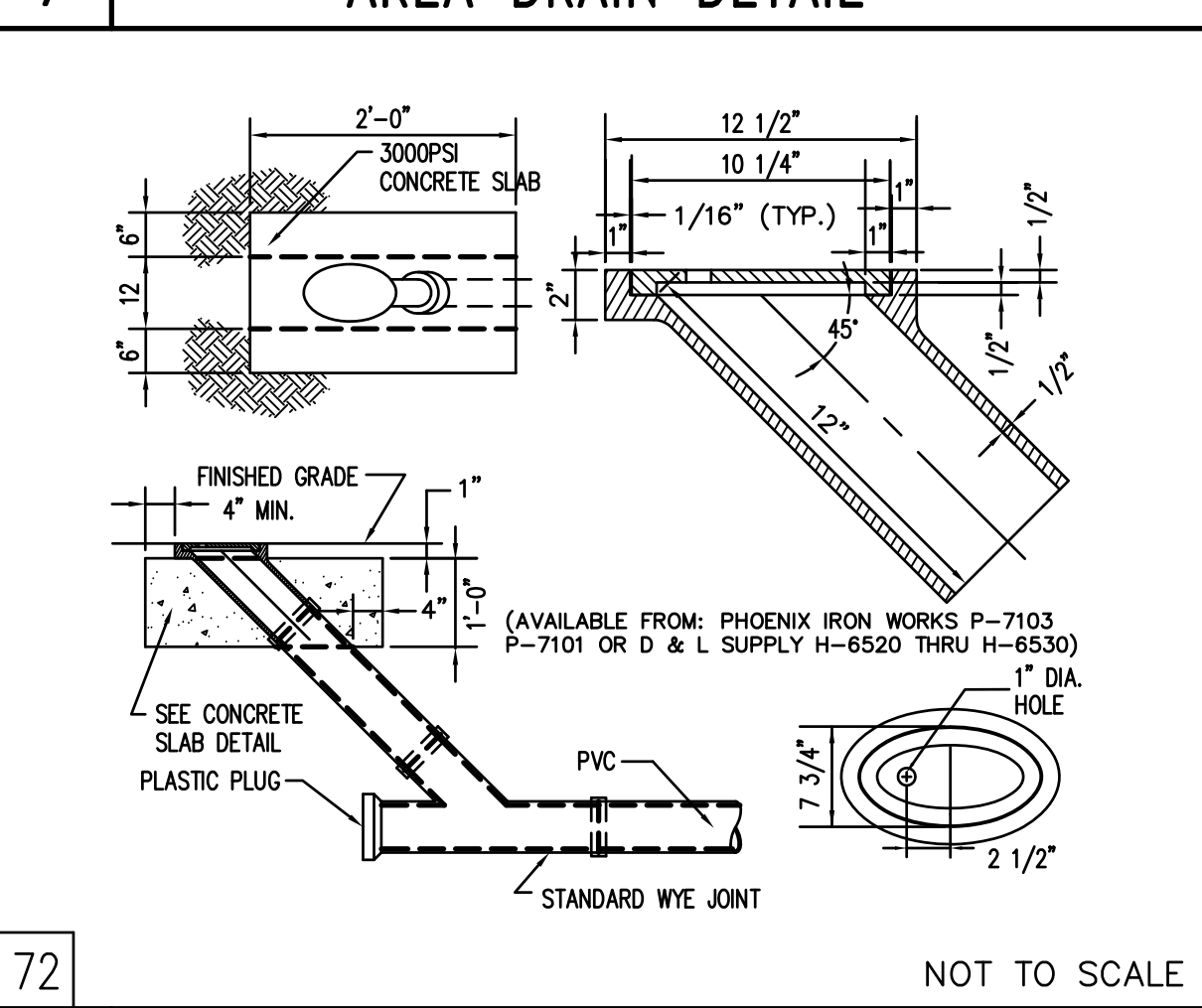

72 8 CLEANOUT AND GRATE DETAIL

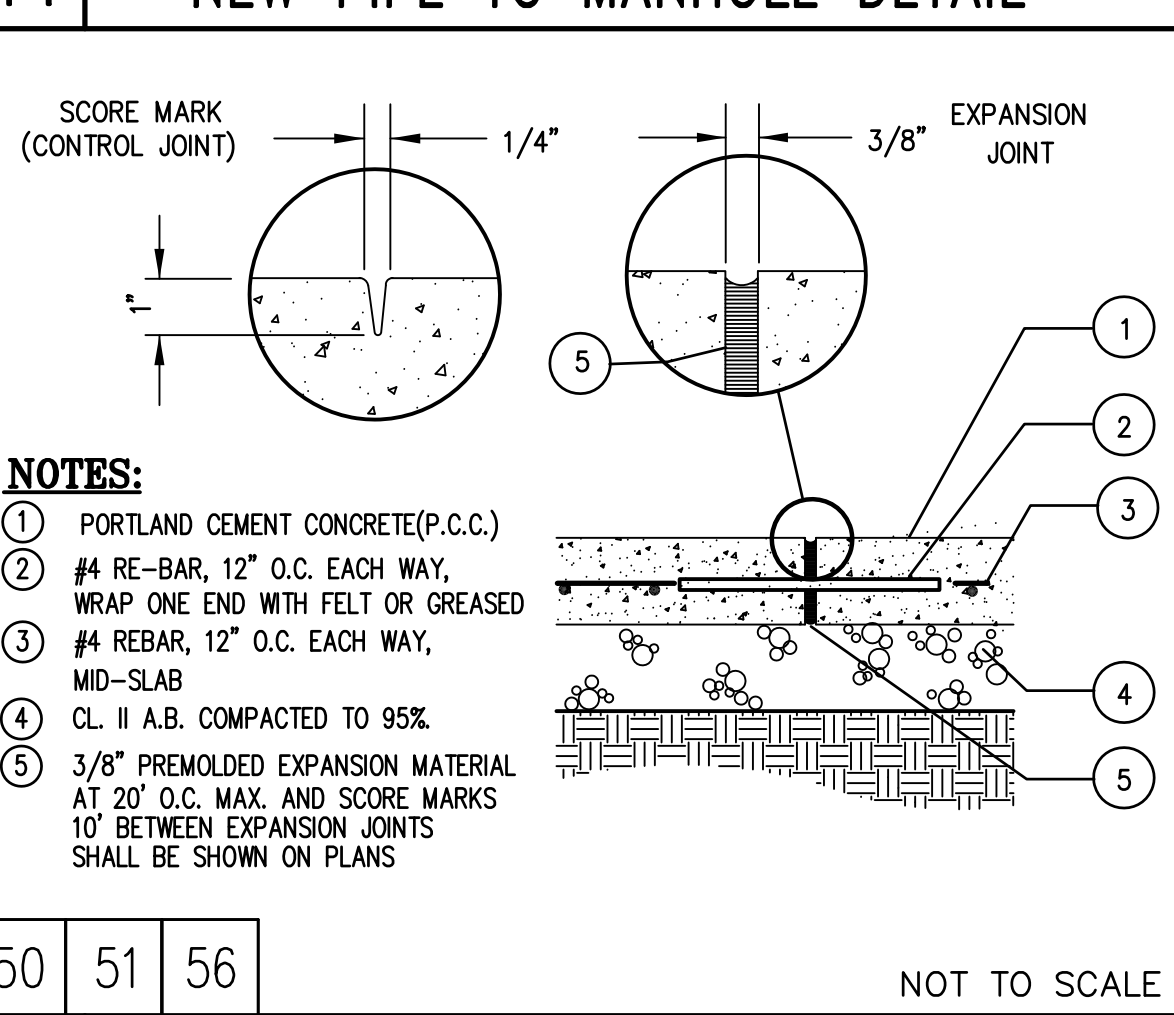

50 51 56 12 EXPANSION AND SCORE JOINTS

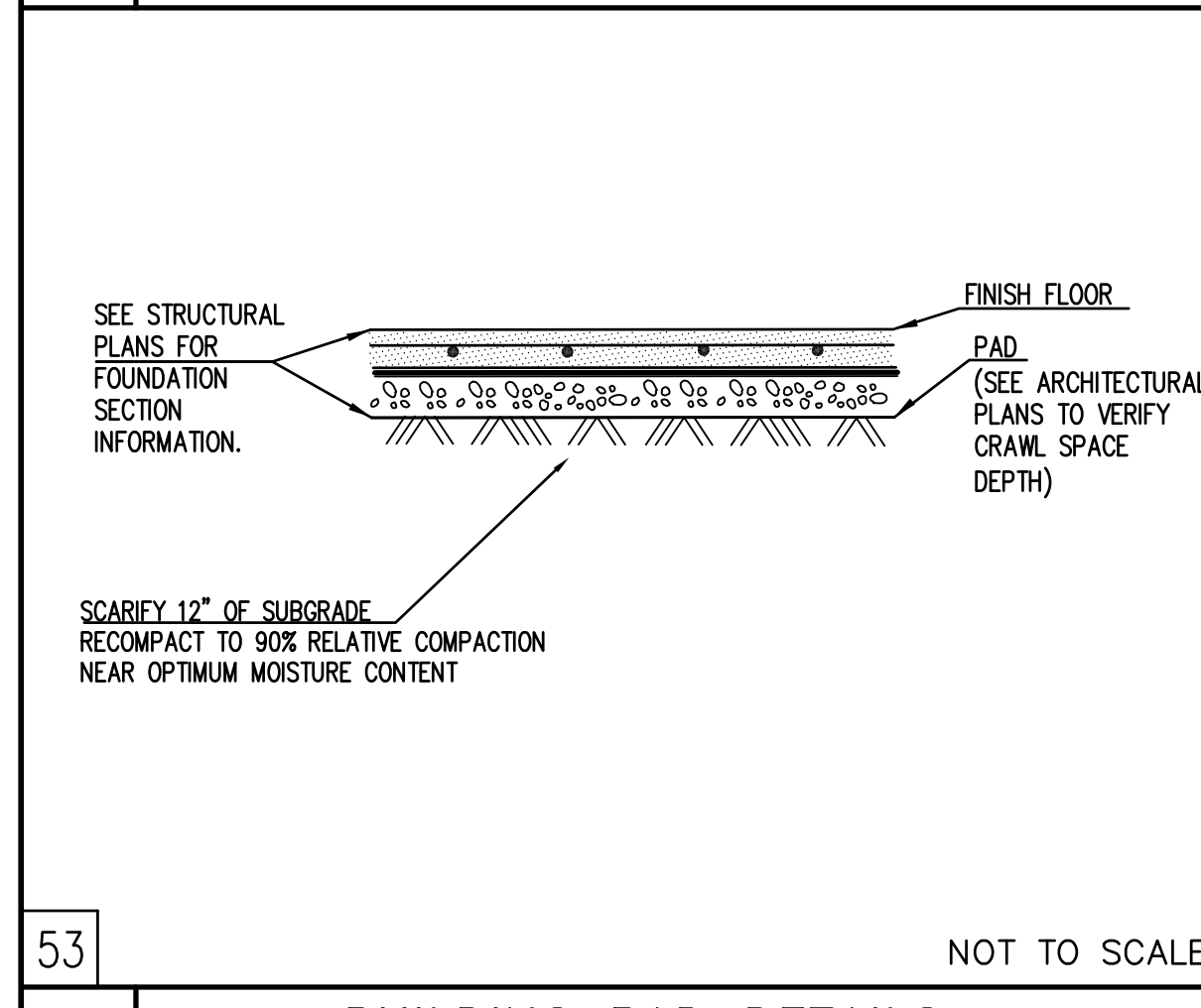

53 4 BUILDING PAD DETAILS

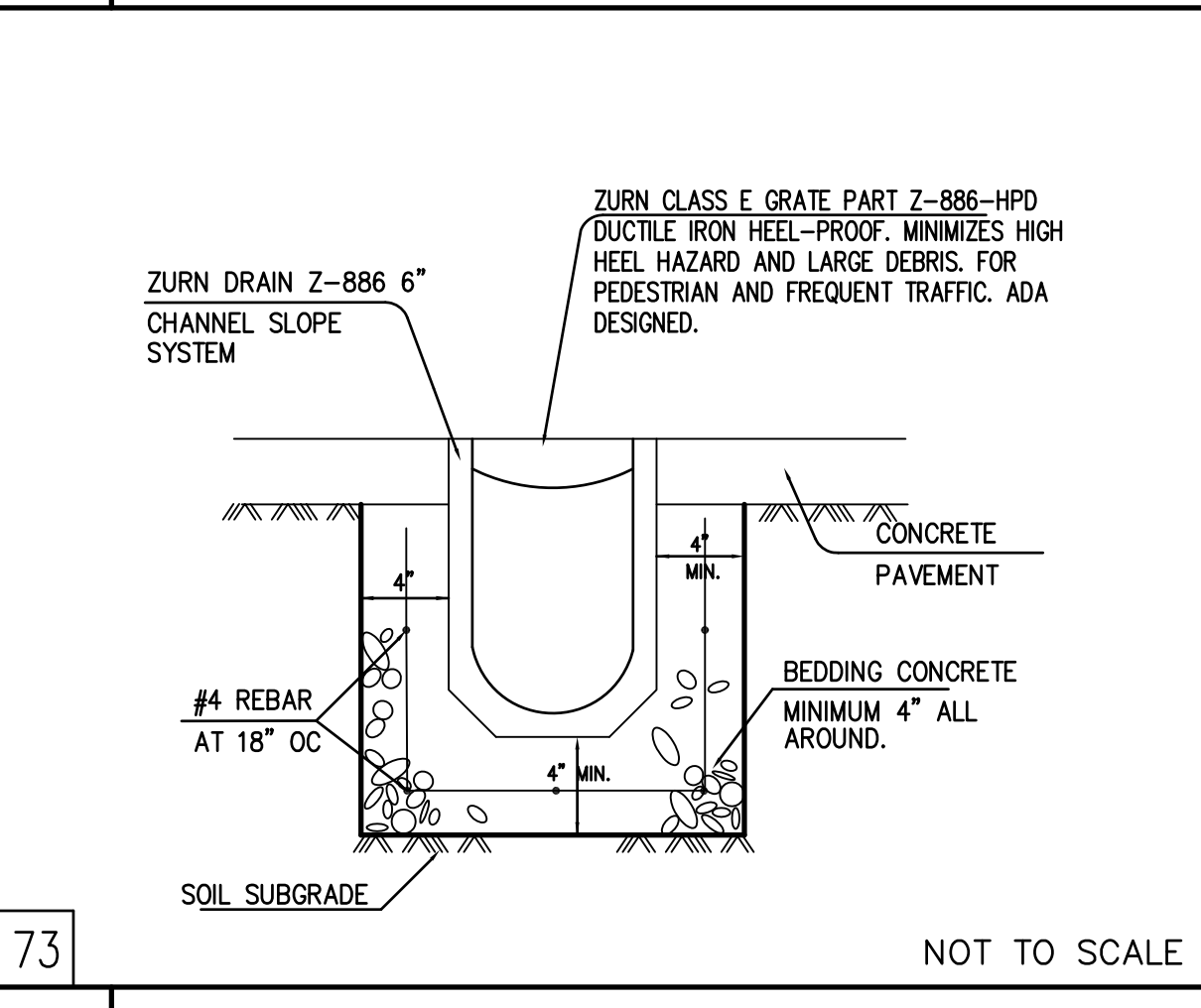

73 9 TRENCH DRAIN DETAILS

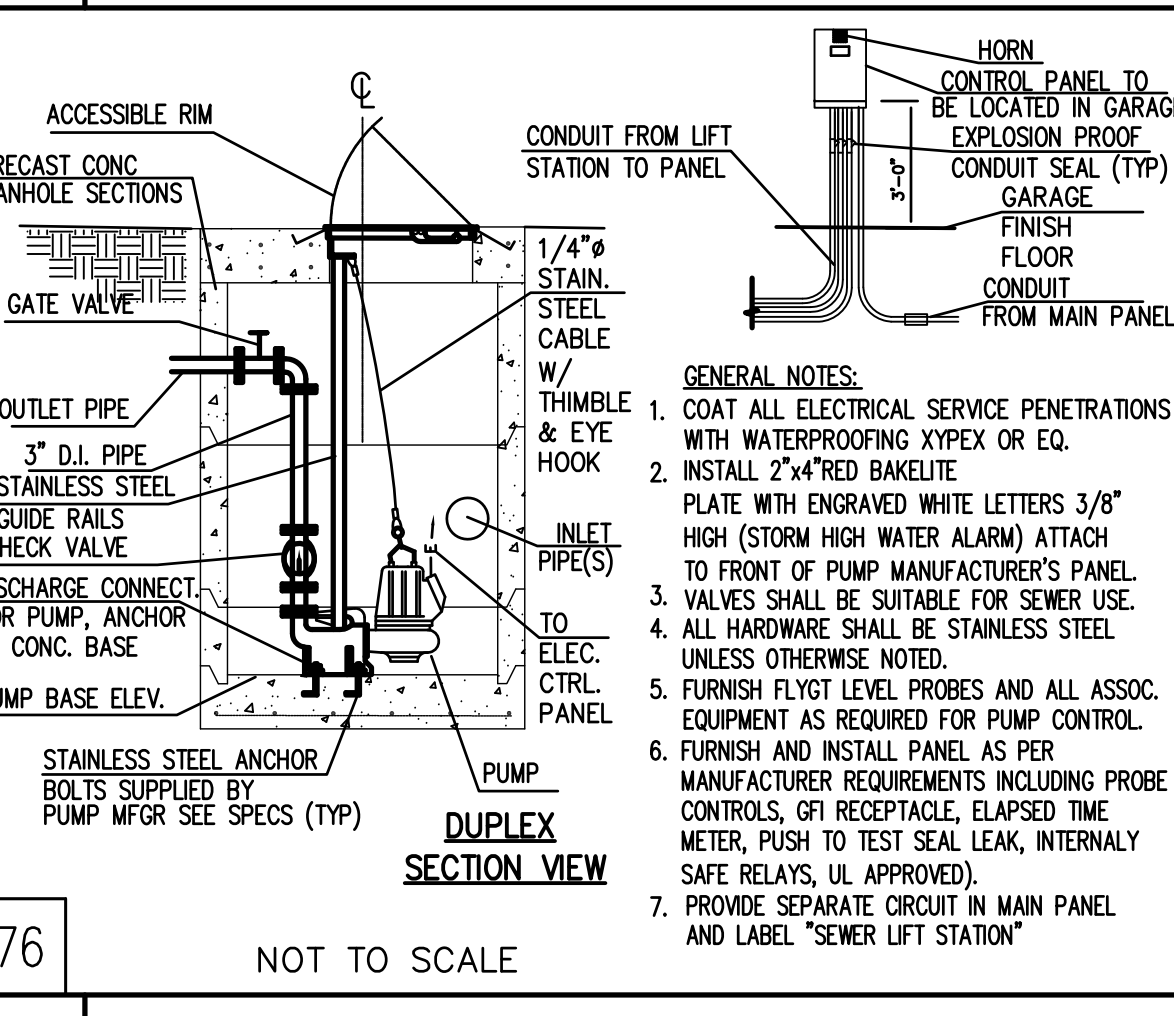

76 13 SANITARY SEWER PUMP DETAILS

Luk and Associates  
 Civil Engineering  
 Land Planning  
 Land Surveying  
 738 Alfred Nobel Drive  
 Hercules, CA 94547  
 Phone (510) 724-3388  
 Fax (510) 724-3383

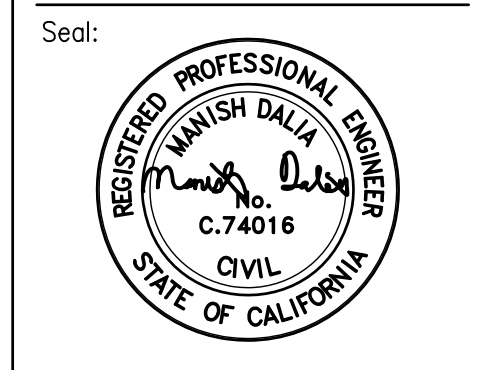

2367 RAINBOW CT.  
 HAYWARD, CA

REVISIONS	DATE
Permit Set	2/14/2018

Date: 2/14/2018  
 Scale: AS NOTED  
 Job No.: 17160A10  
 Dwg: MASTER-17160A10  
 Title: DETAILS

Sheet No.:  
**C-2**

Plot Date:



### GRADING NOTES

- 50 CONSTRUCT CONCRETE VEHICLE PAVEMENT PER DETAIL NO. 1 AND NO. 2, WITH EXPANSION JOINTS PER DETAIL NO. 13 ON SHEET C-2
- 51 CONSTRUCT CONCRETE PEDESTRIAN SIDEWALK PER DETAIL NO. 1, EXPANSION JOINTS AND CONTROL JOINTS PER DETAIL NO. 13 ON SHEET C-2
- 52 INSTALL CONCRETE RETAINING WALL PER DETAIL NO. 4 ON SHEET C-2
- 53 INSTALL BUILDING PAD PER DETAIL NO. 5 ON SHEET C-2. VERIFY FOUNDATION SECTION PRIOR TO CONSTRUCTION. REFER TO ARCHITECTURAL PLANS FOR CRAWL SPACE DETAILS
- 54 INSTALL CONCRETE PEDESTRIAN SIDEWALK STAIRS. SEE LANDSCAPE PLANS FOR DETAILS
- 55 CONSTRUCT DRIVEWAY PER CITY STANDARD DETAIL SD-109. ALSO REFER TO DETAIL NO. 2 ON SHEET C-2
- 56 SAW CUT AND REMOVE EXISTING CONCRETE SIDEWALK, AND CONSTRUCT NEW CONCRETE SIDEWALK PER DETAIL NO. 1 ON SHEET C-2. CONTRACTOR SHALL MATCH EXISTING SCORE LINE PATTERN. MATCH ADJACENT GRADES WITH SMOOTH TRANSITION. CONSTRUCT EXPANSION AND CONSTRUCTION JOINTS PER DETAIL NO. 13 ON SHEET C-2
- 57 REFER TO ARCHITECTURAL DRAWINGS FOR BUILDING FLOOR PLAN AND DETAILS

### EARTHWORK NOTES:

ANALYSIS PERFORMED:

DATE: 2/2/2018

#### EARTHWORK QUANTITIES:

GROSS CUT = 8 CY  
 GROSS FILL = 72 CY  
 NET FILL = 64 CY

1. CONTRACTOR SHALL BE RESPONSIBLE FOR PERFORMING INDEPENDENT QUANTITY ANALYSIS PRIOR TO BIDDING
2. ANALYSIS DOES NOT ACCOUNT FOR TRENCH SPOILS, FOOTINGS, OR SOIL-MITIGATION/OVER-EXCAVATION WORK.

### LEGEND

- CONCRETE VEHICULAR
- CONCRETE PEDESTRIAN SIDEWALK
- LIMIT OF IMPROVEMENT. CONTRACTOR SHALL PROTECT EXISTING SITE FEATURES OUTSIDE THE IMPROVEMENT LIMIT

## Luk and Associates

Civil Engineering  
 Land Planning  
 Land Surveying  
 738 Alfred Nobel Drive  
 Hercules, CA 94547  
 Phone (510) 724-3368  
 Fax (510) 724-3383

Seal:



2367 RAINBOW CT.  
 HAYWARD, CA

REVISIONS	DATE
Permit Set	2/14/2018

Date: 2/14/2018  
 Scale: 1"=10'  
 Job No.: 17160A10  
 Dwg: MASTER-17160A10  
 Title:  
**GRADING PLAN**

Sheet No.:  
C-3  
 Plot Date:

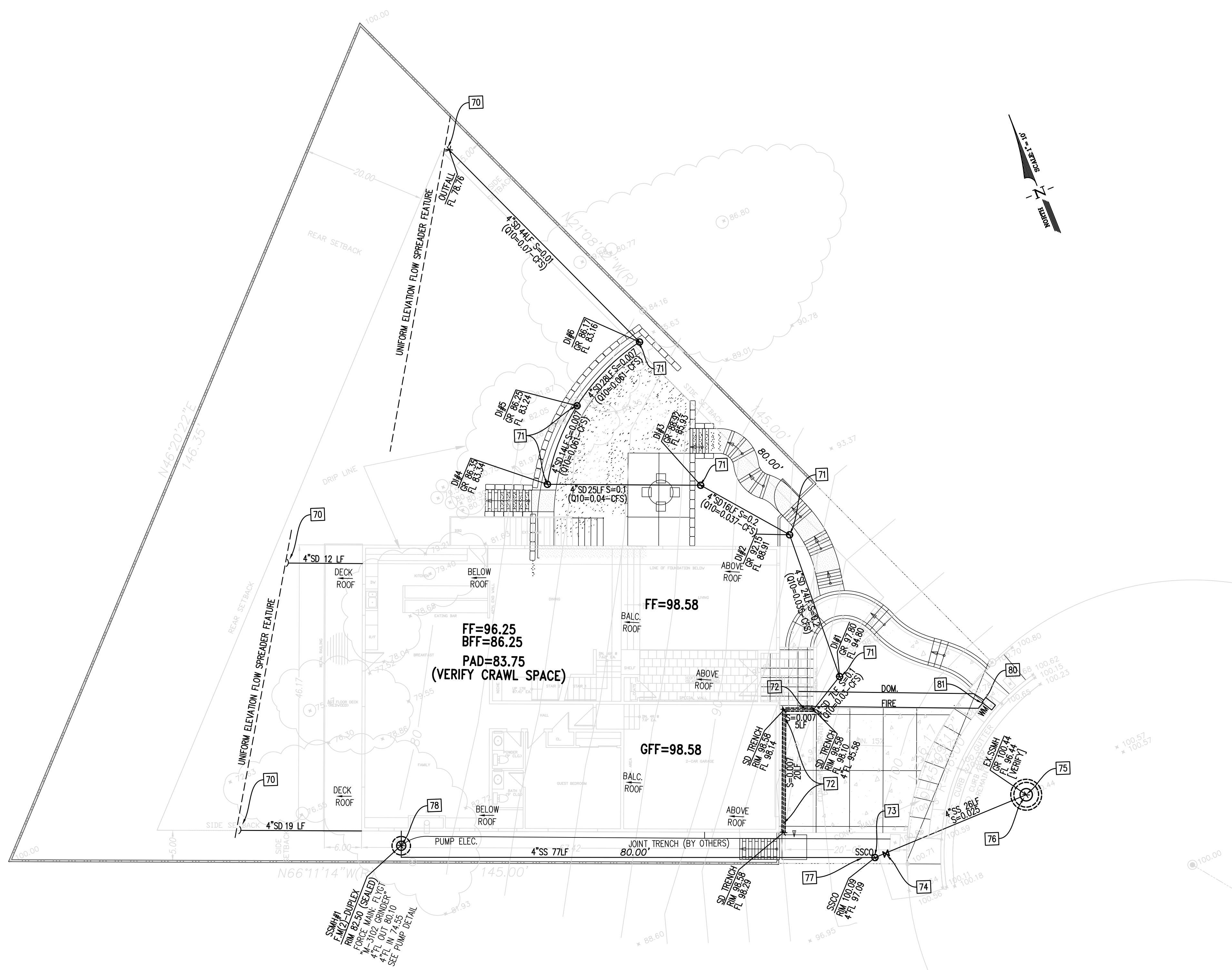

**UTILITY NOTES:**

- 70 DISCHARGE PIPE TO TOP OF FLOW SPREADER AT LOCATION SHOWN PER DETAIL NO. 5 ON SHEET C-2
- 71 INSTALL STORM DRAIN STRUCTURE PER STORM DRAIN SCHEDULE ON THIS SHEET AND ASSOCIATED UNDERGROUND STORM DRAIN PIPE AS SHOWN ON THE PLAN.
- 72 INSTALL TRENCH DRAIN PER DETAIL NO. 9 ON SHEET C-2
- 73 INSTALL SANITARY SEWER CLEANOUT PER DETAIL NO. 8 ON SHEET C-2
- 74 INSTALL CHECK VALVE PER DETAIL NO. 10 ON SHEET C-2
- 75 POT HOLE EXISTING SEWER SYSTEM AT POINT OF CONNECTION AND VERIFY THAT EXISTING DEPTH AND SIZE IS ADEQUATE TO PROVIDE SERVICE TO PROPOSED BUILDING SERVICE. CONTRACTOR TO NOTIFY THE ENGINEER IF ANY CONFLICTS ARE FOUND.
- 76 CONNECT NEW SANITARY SEWER LATERAL PIPE TO SANITARY MAIN PER CITY STANDARD DETAIL "SD-312", AND AS PROVIDED ON DETAIL NO. 11 ON SHEET C-2.
- 77 CONNECT SEWER LATERAL TO NEW FORCE MAIN AND BUILDING POINT OF CONNECTION.
- 78 INSTALL SANITARY SEWER PUMP AND ALL ASSOCIATED HARDWARE, INCLUDING PUMP FLOAT-TRIGGER(S) AND ELECTRICAL SUPPORT SERVICE(S) PER DETAIL NO. 13 ON SHEET C-2.
- 79 PROVIDE ELECTRICAL POWER SUPPLY TO PUMP SYSTEM AS REQUIRED TO MEET PUMP MANUFACTURER'S POWER SPECIFICATIONS. BACK-UP ELECTRICAL POWER SUPPLY (VIA GENERATOR/BATTERY SOURCE, PROVIDED BY OTHERS) TO PUMP SHALL SWITCH ON IN THE EVENT OF A POWER OUTAGE; POWER SUPPLY CONFIGURATION SHALL BE DESIGN-BUILT TO PROVIDE A FAIL-SAFE TRANSFER FROM THE MAIN ELECTRICAL POWER SOURCE TO THE SECONDARY BACK-UP POWER SOURCE, IN THE EVENT OF A POWER OUTAGE, AND ALLOW A SWITCH-BACK TO MAIN POWER, ONCE MAIN-POWER COMES BACK ONLINE.
- 80 INSTALL NEW DOMESTIC WATER SERVICE ON-SITE PIPING AND CONNECT TO EXISTING WATER METER AS SHOWN ON THE PLAN
- 81 INSTALL NEW FIRE WATER SERVICE ON-SITE PIPING AND CONNECT TO EXISTING METER AS SHOWN ON THE PLAN

ON-SITE STORM DRAIN SCHEDULE		
STRUCTURE NUMBER	MODEL	INLET INSIDE DIAMETER
DI#1 - #6	NDS PART NO. 13 CLASS A LID COVER, OR EQUAL.	4" ROUND COVER ON 4" SD
TRENCH DRAIN	ZURN MODEL Z-866	6" WIDE 4" END OUTLET

**Luk and Associates**  
 Civil Engineering  
 Land Planning  
 Land Surveying  
 738 Alfred Nobel Drive  
 Hercules, CA 94547  
 Phone (510) 724-3388  
 Fax (510) 724-3383

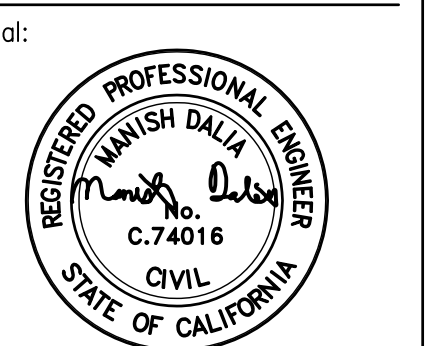

2367 RAINBOW CT.  
HAYWARD, CA

REVISIONS	DATE
Permit Set	2/14/2018

Date: 2/14/2018  
 Scale: 1"=10'  
 Job No.: 17160A10  
 Dwg: MASTER-17160A10  
 Title:  
**UTILITY PLAN**

Sheet No.:  
C-4

Plot Date:

**GENERAL CITY EROSION AND SEDIMENT CONTROL NOTES:**

- IT SHALL BE THE OWNER'S RESPONSIBILITY TO MAINTAIN CONTROL OF THE ENTIRE CONSTRUCTION OPERATION AND TO KEEP THE ENTIRE SITE IN COMPLIANCE WITH THE SOIL EROSION CONTROL PLAN.
- CIVIL ENGINEER (QSD): LUK AND ASSOCIATES, 738 ALFRED NOBEL DRIVE, HERCULES, CALIFORNIA 94547 (510) 724-3388.
- CONTRACTOR: T.B.D.
- CONSTRUCTION QSP: T.B.D.
- CONSTRUCTION SCHEDULE: T.B.D.
- THIS PLAN IS INTENDED TO BE USED FOR INTERIM EROSION AND SEDIMENT CONTROL ONLY AND IS NOT TO BE USED FOR FINAL ELEVATIONS OR PERMANENT IMPROVEMENTS.
- CONTRACTOR (QUALIFIED QSP) SHALL BE RESPONSIBLE FOR MONITORING EROSION AND SEDIMENT CONTROL MEASURES PRIOR, DURING, AND AFTER STORM EVENTS.
- SLOPES EQUAL OR EXCEEDING 3:1 SHALL RECEIVE EROSION CONTROL FABRIC SUCH AS JUTE NETTING; AND SLOPES EQUAL OR EXCEEDING 2:1 SHALL RECEIVE EROSION CONTROL FABRIC AND COMPOST SOCK AT THE INTERVAL SPECIFIED BY THE LANDSCAPE ARCHITECT
- REASONABLE CARE SHALL BE TAKEN WHEN HAULING ANY EARTH, SAND, GRAVEL, STONE, DEBRIS, PAPER OR ANY OTHER SUBSTANCE OVER ANY PUBLIC STREET, ALLEY OR OTHER PUBLIC PLACE. SHOULD ANY BLOW, SPILL, OR TRACK OVER AND UPON SAID PUBLIC OR ADJACENT PRIVATE PROPERTY, IMMEDIATE REMEDY SHALL OCCUR.
- SANITARY FACILITIES SHALL BE MAINTAINED ON THE SITE.
- ALL PAVED AREAS SHALL BE KEPT CLEAR OF EARTH MATERIAL AND DEBRIS. THE SITE SHALL BE MAINTAINED SO AS TO MINIMIZE SEDIMENT LADEN RUNOFF TO ANY STORM DRAINAGE SYSTEM, INCLUDING EXISTING DRAINAGE SWALES AND WATER COURSES.
- CONSTRUCTION OPERATIONS SHALL BE CARRIED OUT IN SUCH A MANNER THAT EROSION AND WATER POLLUTION WILL BE MINIMIZED. STATE AND LOCAL LAWS CONCERNING POLLUTION ABATEMENT SHALL BE COMPLIED WITH.
- CONTRACTOR SHALL PROVIDE DUST CONTROL AS REQUIRED BY THE APPROPRIATE FEDERAL, STATE AND LOCAL AGENCY REQUIREMENTS.

**EROSION AND SEDIMENT CONTROL MEASURES:**

- THE FACILITIES SHOWN ON THIS PLAN ARE DESIGNED TO CONTROL EROSION AND SEDIMENT DURING THE ENTIRE DURATION OF CONSTRUCTION. FACILITIES ARE TO BE OPERABLE AT ALL TIMES. GRADING OPERATIONS DURING THE RAINY SEASON WHICH LEAVE DENUDE SLOPES SHALL BE PROTECTED WITH EROSION CONTROL MEASURES IMMEDIATELY FOLLOWING GRADING ON THE SLOPES.
- THIS PLAN COVERS ONLY THE PROJECT SITE CONDITIONS AS SHOWN ON THE EROSION CONTROL PLAN. ADDITIONAL EROSION CONTROL PLANS SHALL BE DESIGNED, EVALUATED, AND REVISIONED AS NECESSARY PER STAGE OF CONSTRUCTION WITH THE APPROVAL OF THE CITY ENGINEER. PLANS ARE TO BE RESUBMITTED FOR CITY APPROVAL PRIOR TO EACH NEW STAGE OF CONSTRUCTION, UNTIL COMPLETION OF PROJECT CONSTRUCTION, AND UNTIL COMPLETION OF THE POST CONSTRUCTION BEST MANAGEMENT PRACTICES FACILITIES ARE ACCEPTED BY THE CITY.
- CONSTRUCTION ENTRANCES SHALL BE INSTALLED PRIOR TO COMMENCEMENT OF GRADING. ALL CONSTRUCTION TRAFFIC ENTERING ONTO THE PAVED ROADS MUST CROSS THE STABILIZED CONSTRUCTION ENTRANCEWAYS.
- CONTRACTOR SHALL MAINTAIN STABILIZED ENTRANCE AT EACH VEHICLE ACCESS POINT TO EXISTING PAVED STREETS. ANY MUD OR DEBRIS TRACKED ONTO PUBLIC STREETS SHALL BE REMOVED DAILY AND AS REQUIRED BY THE CITY.
- IF HYDROSEEDING IS NOT USED OR IS NOT EFFECTIVE, THEN OTHER IMMEDIATE METHODS SHALL BE IMPLEMENTED, SUCH AS EROSION CONTROL BLANKETS, OR A THREE-STEP APPLICATION OF 1) SEED, MULCH, FERTILIZER, (2) BLOW STRAW, 3) TACKIFIER AND MULCH.
- INLET PROTECTION SHALL BE INSTALLED AT OPEN INLETS TO PREVENT SEDIMENT FROM ENTERING THE STORM DRAIN SYSTEM. INLETS NOT USED IN CONJUNCTION WITH EROSION CONTROL ARE TO BE BLOCKED TO PREVENT ENTRY OF SEDIMENT.
- AREAS WHERE THERE IS ACTIVE GRADING WILL NOT BE HYDROSEEDED. AREAS THAT ARE INACTIVE AND LEFT EXPOSED TO THE WEATHER SHALL BE HYDROSEEDED OR OTHERWISE PROTECTED FROM EROSION.
- THIS EROSION AND SEDIMENT CONTROL PLAN MAY NOT COVER ALL THE SITUATIONS THAT MAY ARISE DURING CONSTRUCTION DUE TO UNANTICIPATED FIELD CONDITIONS. VARIATIONS AND ADDITIONS MAY BE MADE TO THIS PLAN IN THE FIELD. NOTIFY THE CITY REPRESENTATIVE OF ANY FIELD CHANGES.

**EROSION CONTROL NOTES:**

- CONTRACTOR IS RESPONSIBLE FOR ALL ASPECTS OF "EROSION CONTROL" AND SHALL INSTALL AND MAINTAIN ANY DEVICES AND MEASURES NECESSARY, ALL YEAR ROUND, TO THE SATISFACTION OF THE CITY ENGINEER.
- TO MINIMIZE EROSION OF OPEN GRADED BANKS, ALL OPEN GRADED BANKS SHALL BE HYDROSEEDED, LANDSCAPED OR SEALED. ANY CONCRETE LINED "V" DITCHES DESIGNED TO PROTECT THE BANKS SHALL BE CONSTRUCTED WHEN THE GRADING OF THE BANKS IS COMPLETED. IF THE PERMANENT STORM DRAIN SYSTEM IS NOT CONSTRUCTED TO ACCEPT DISCHARGE FROM THESE DITCHES, TEMPORARY DITCHES SHALL BE CONSTRUCTED TO CONTAIN THE STORM WATER AND DIRECT IT, IN A MANNER THAT AVOIDS EROSION OF THE BANKS, TO THE EROSION AND SEDIMENT CONTROL FACILITIES.
- THE CONTRACTOR SHALL PLACE 2"-3" COARSE, DRAIN ROCK AS A GRAVEL ROADWAY (6" MIN. THICK FOR THE FULL WIDTH) AT EACH ENTRANCE TO THE SITE. ANY MUD THAT IS TRACKED ONTO PUBLIC STREETS SHALL BE REMOVED THAT SAME DAY AND AS REQUIRED BY THE CITY OF HAYWARD.
- ALL EROSION CONTROL MEASURES SHALL BE MAINTAINED UNTIL DISTURBED AREAS ARE STABILIZED, AND CHANGES TO THIS EROSION AND SEDIMENT CONTROL PLAN SHALL BE MADE TO MEET FIELD CONDITIONS ONLY WITH THE APPROVAL OF THE CITY ENGINEER.
- ALL EROSION CONTROL FACILITIES MUST BE INSPECTED AND REPAIRED AT THE END OF EACH WORKING DAY OR DAILY DURING THE RAINY SEASON.
- BORROW AREAS AND TEMPORARY STOCKPILES SHALL BE PROTECTED WITH APPROPRIATE EROSION CONTROL MEASURES TO THE SATISFACTION OF THE CITY ENGINEER.
- ALL CUT AND FILL SLOPES ARE TO BE PROTECTED TO PREVENT OVERBACK FLOW.
- 

**MAINTENANCE NOTES:**

- MAINTENANCE IS TO BE PERFORMED AS FOLLOWS:
  - REPAIR DAMAGES CAUSED BY SOIL EROSION OR CONSTRUCTION AT THE END OF EACH WORKING DAY.
  - SEDIMENT TRAPS, BERMS, OR SWALES ARE TO BE INSPECTED AFTER EACH STORM AND REPAIRS MADE AS NEEDED.
  - ACCUMULATED SEDIMENTS SHALL BE REMOVED AND SEDIMENT FACILITY RESTORED TO ITS ORIGINAL CONDITIONS WHEN SEDIMENT HAS ACCUMULATED TO A DEPTH ONE HALF THE HEIGHT OF THE SEDIMENT FACILITY.
  - SEDIMENT REMOVED SHALL BE DEPOSITED IN A SUITABLE AREA AND IN SUCH A MANNER THAT IT WILL NOT ERODE.
  - ANY RILLS AND GULLIES MUST BE REPAIRED.
- ANY SAND BAG INLET PROTECTION SHALL BE CLEANED OUT WHENEVER SEDIMENT DEPTH IS ONE HALF THE HEIGHT OF ONE SAND BAG.

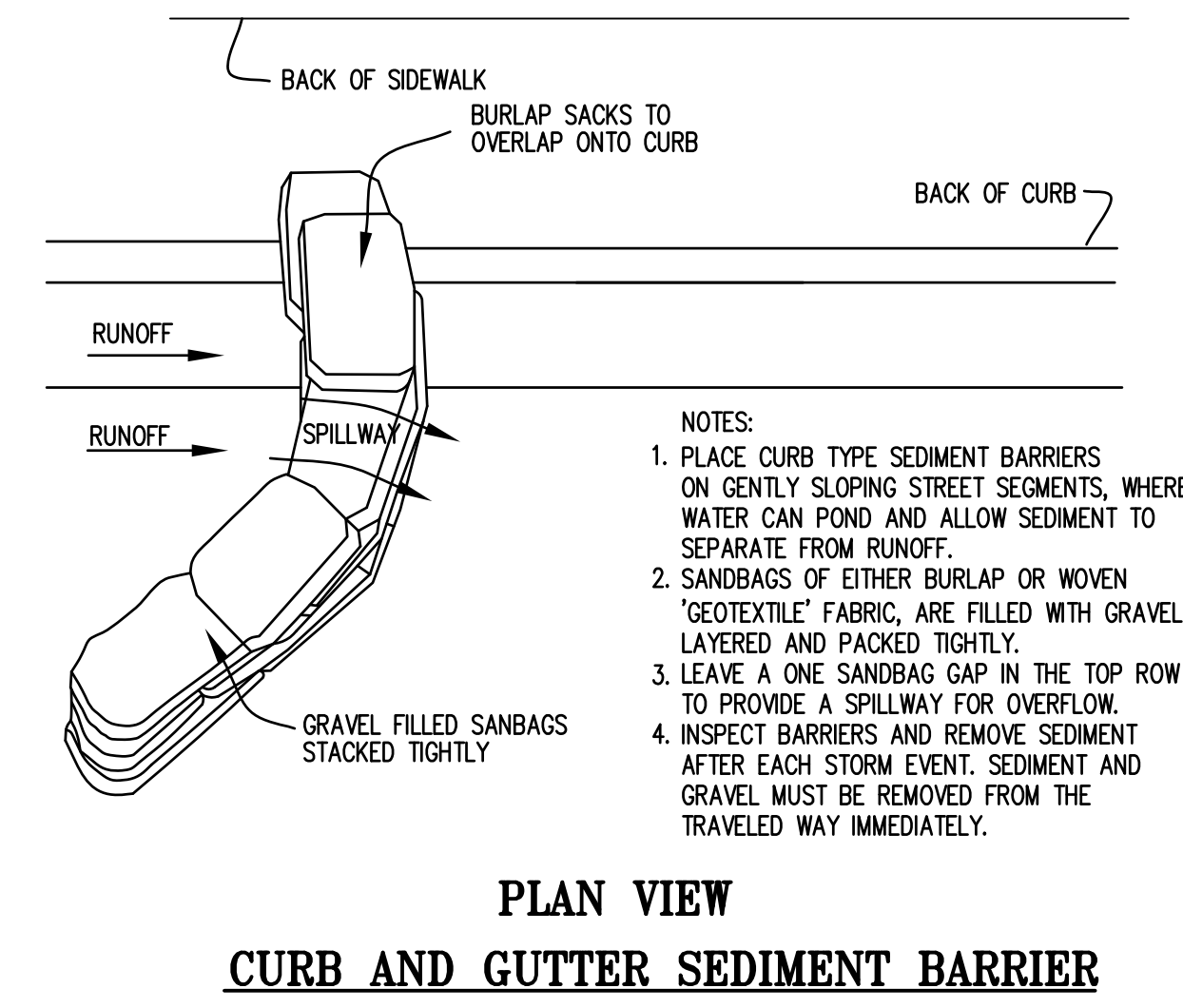
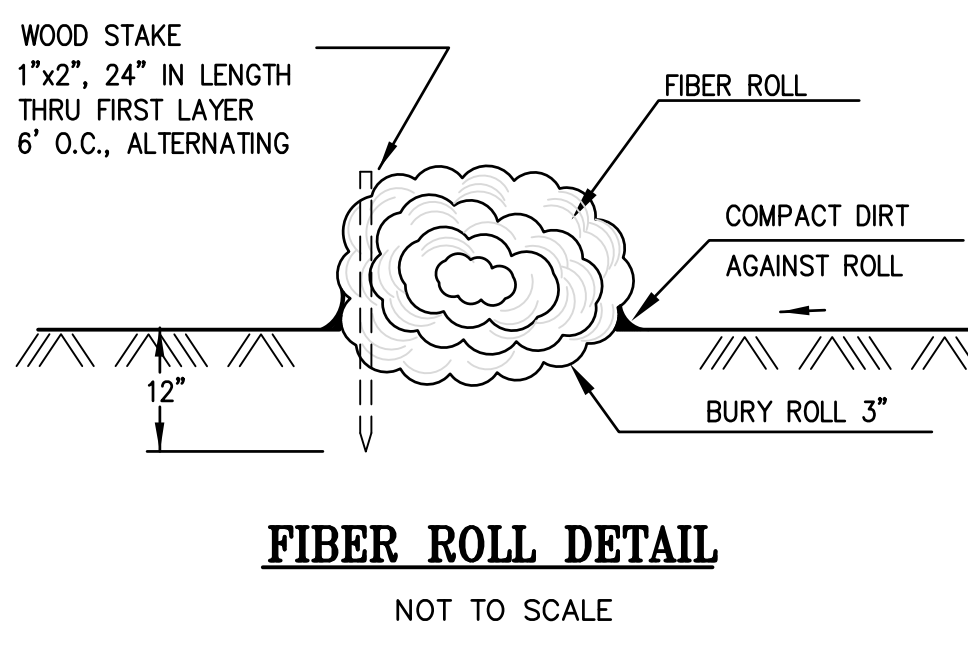
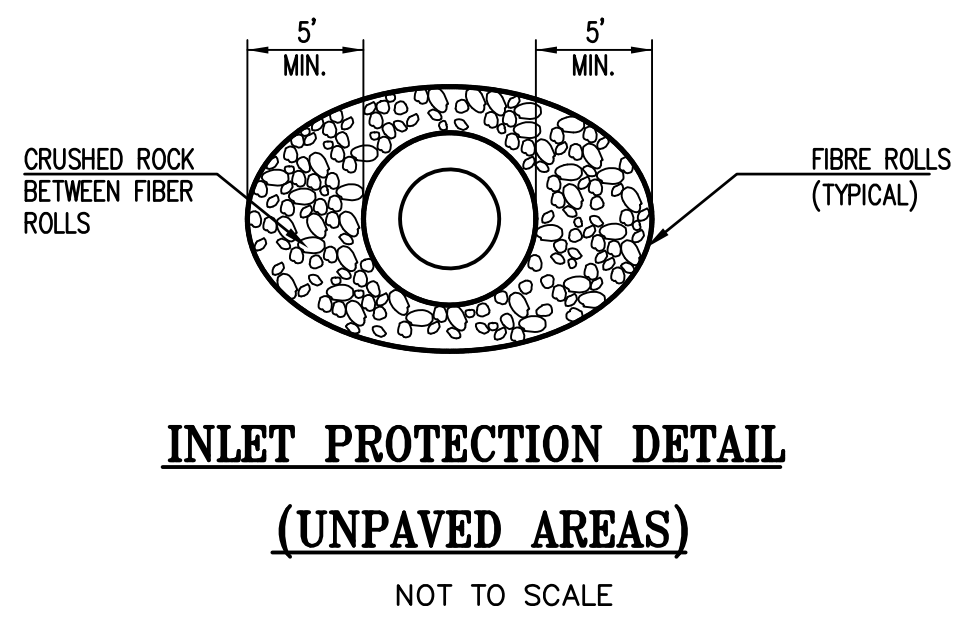
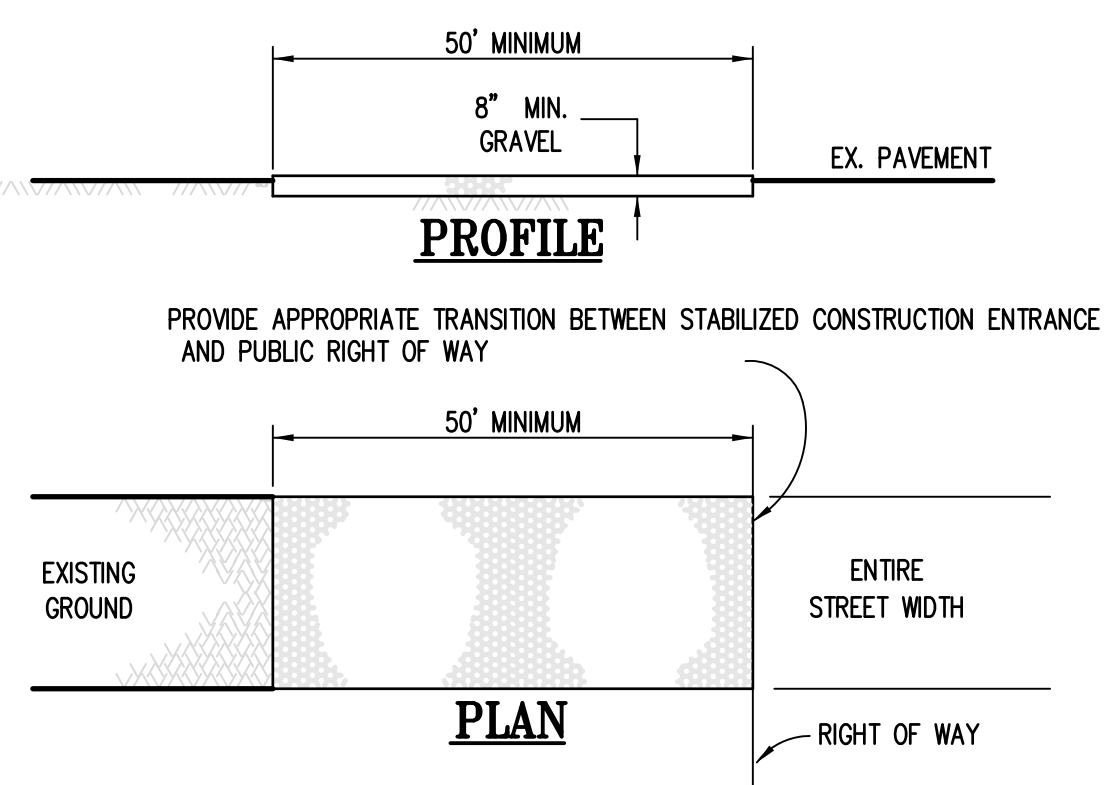
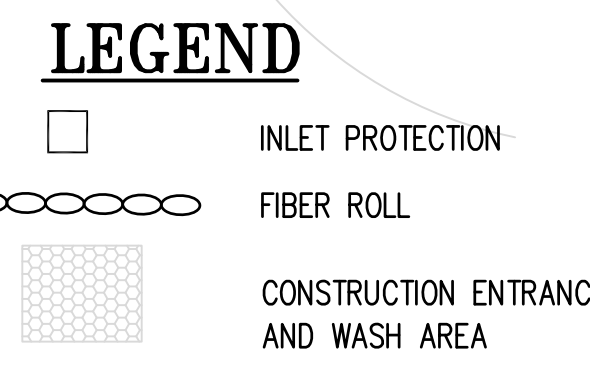
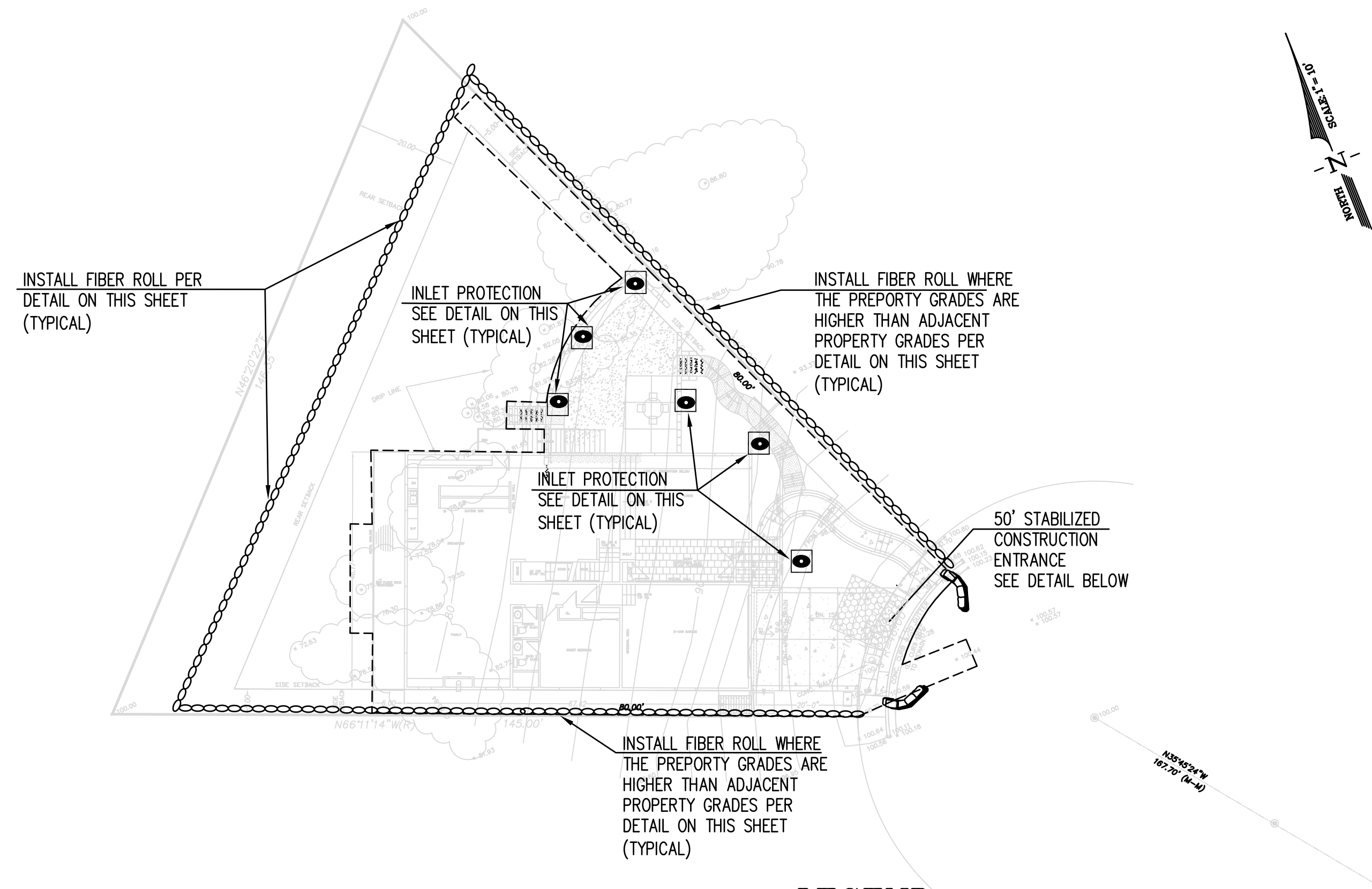

**CONSTRUCTION SPECIFICATIONS**

- THE MATERIAL FOR CONSTRUCTION SHALL BE 2 TO 3 INCH ROCK
- LENGTH - AS EFFECTIVE, BUT NOT LESS THAN 50 FEET.
- THICKNESS - NOT LESS THAN EIGHT (8) INCHES.
- WIDTH - NOT LESS THAN FULL WIDTH OF ALL POINTS OF INGRESS OR EGRESS.
- WASHING - WHEN NECESSARY, WHEELS SHALL BE CLEANED TO REMOVE SEDIMENT PRIOR TO ENTRANCE ONTO PUBLIC RIGHT OF WAY. WHEN WASHING IS REQUIRED, IT SHALL BE DONE ON AN AREA STABILIZED WITH CRUSHED STONE WHICH DRAINS INTO AN APPROVED SEDIMENT TRAP OR SEDIMENT BASIN. ALL SEDIMENT SHALL BE PREVENTED FROM ENTERING ANY STORM DRAIN, DITCH, OR WATERCOURSE THROUGH USE OF SAND BAGS, GRAVEL BOARDS OR OTHER APPROVED METHODS.
- MAINTENANCE - THE ENTRANCE SHALL BE MAINTAINED IN A CONDITION WHICH WILL PREVENT TRACKING OR FLOWING OF SEDIMENT ONTO PUBLIC RIGHT OF WAY. THIS MAY REQUIRE PERIODIC TOP DRESSING WITH ADDITIONAL STONE AS CONDITIONS DEMAND AND REPAIR AND/OR CLEANOUT OF ANY MEASURES USED TO TRAP SEDIMENT. ALL SEDIMENT SPILLED, DROPPED, WASHED OR TRACKED ONTO PUBLIC RIGHT OF WAY MUST BE REMOVED IMMEDIATELY.

**TEMPORARY GRAVEL CONSTRUCTION**

**ENTRANCE/EXIT DETAIL**

NOT TO SCALE

**Luk and Associates**  
 Civil Engineering  
 Land Planning  
 Land Surveying  
 738 Alfred Nobel Drive  
 Hercules, CA 94547  
 Phone (510) 724-3388  
 Fax (510) 724-3383

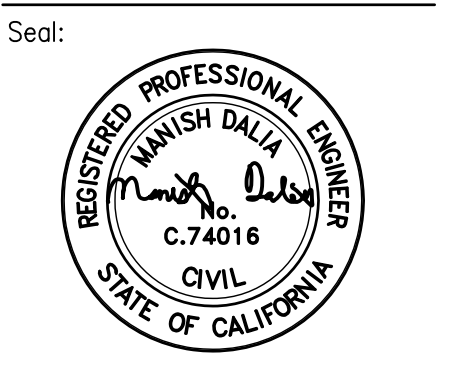

2367 RAINBOW CT.  
 HAYWARD, CA

REVISIONS	DATE
Permit Set	2/14/2018

Date: 2/14/2018  
 Scale: 1"=20'  
 Job No.: 17160A10  
 Dwg: MASTER-17160A10  
 Title:  
 EROSION CONTROL PLAN

**GEOTECHNICAL ENGINEERING & GEOLOGIC  
INVESTIGATION.RECOMMENDATIONS  
REPORT  
PROPOSED NEW HOME  
2367 RAINBOW COURT , HAYWARD , CA  
LOT 5 TR 3992 ; APN 425-0410-026**

**Date: October 30 th , 2016**

REPORT PREPARED FOR:

**QUAN TRAN  
[Btbuilder.quan@yahoo.com](mailto:Btbuilder.quan@yahoo.com)  
510.390.1580**

**RECEIVED**  
MAR 22 2018  
PLANNING DIVISION

**HALLENBECK / ALLWEST**



East Bay  
P.O. Box 1473  
El Cerrito, CA 94530

Peninsula  
P.O. Box 1666  
San Bruno, CA 94066

### Hallenbeck/Allwest

Geotechnical Engineering Consultants

Tel (650) 219-4290 Fax (650) 583-1219

Email: [adelkasim@gmail.com](mailto:adelkasim@gmail.com)

Quan Tran

[Btbuilder.quan@yahoo.com](mailto:Btbuilder.quan@yahoo.com)

Tel: 510.390.1580

Project 7970 GP

October 30 th , 2016

**RE: GEOTECHNICAL ENGINEERING & GEOLOGIC  
INVESTIGATION.RECOMMENDATIONS REPORT  
PROPOSED NEW HOME  
2367 RAINBOW COURT , HAYWARD , CA  
LOT 5 TR 3992 ; APN 425-0410-026**

Our firm has completed this combined geotechnical engineering and geologic investigation of the subject vacant lot, proposed for the construction of a new single family home along with appurtenant improvements.

This investigation identified geotechnical and geologic conditions in support of the Project permitting and to develop design -level recommendations for the proposed project . The recommendations include Sections for : Structural Pier Foundations , Structural Retaining Walls , Grading , Seismic Considerations and Drainage .

Our investigation methodology , scope and assessment is in compliance with the City of Hayward Planning Department Requisition Items # 3 & # 4 and geotechnical practice standards. The site is outside the A-P regulatory earthquake fault rupture zones and is outside regional large - scale active landslides.

This report includes the results of the field exploration , as well as testing , that was undertaken to substantiate the conclusions and feasibility assessments . Site -Specific exploratory geo borings, were drilled and logged by the geotechnical engineer, to cross - profile the sloping site. The scope of the report incorporates the November 1989 subdivision geologic report , as pertinent to subject Lot 5.

We point out that this report provides geotechnical assessments and recommendations for the project ,based on our observations , the results of our field and laboratory work as well as ,our engineering analyses ; and considering the description of the project relayed to us by the project owner.

Please direct any questions with regards to this document to the undersigned geotechnical engineer.

Very Truly Yours,  
Hallenbeck / Allwest

Adel Kasim ,Ph.D , GE # 453  
Principal Geotechnical Engineer

Michael Carey, CEG # 1531  
Certified Engineering Geologist  
Prepared the Geology Section



East Bay  
P.O. Box 1473  
El Cerrito, CA 94530

Peninsula  
P.O. Box 1666  
San Bruno, CA 94066

## Hallenbeck/Allwest

Geotechnical Engineering Consultants

Tel (650) 219-4290 Fax (650) 583-1219

Email: [adelkasim@gmail.com](mailto:adelkasim@gmail.com)



**TABLE OF CONTENTS**

	<b>Page</b>
<b>Letter of Transmittal</b>	
<b>PROJECT SCOPE AND SITE DESCRIPTION</b>	<b>5</b>
<b>REGIONAL GEOLOGY .ENGINEERING GEOLOGY</b>	<b>6</b>
<b>GEOTECHNICAL INVESTIGATION . CONDITIONS</b>	<b>8</b>
<b>CONCLUSIONS</b>	<b>9</b>
<b>GEOTECHNICAL RECOMMENDATIONS (DESIGN LEVEL)</b>	<b>10</b>
<b>1.BUILDING FOUNDATIONS</b>	
<b>PIERS.DRILLED CAST IN-PLACE</b>	<b>10</b>
<b>2.STRUCTURAL RETAINING WALLS</b>	<b>11</b>
<b>3.GRADING</b>	<b>14</b>
<b>4. GEO EARTHQUAKE CONSIDERATIONS</b>	<b>14</b>
<b>5. DRAINAGE: AREAL SITE . SUBSURFACE</b>	<b>15</b>
<b>6. DRIVEWAY AND GARAGE</b>	<b>16</b>
<b>7. PLANS REVIEW AND CONSTRUCTION SPECIAL     INSPECTIONS.TESTING</b>	<b>16</b>
<b>NOTICE</b>	
<b>REFERENCES</b>	

**FIGURES:**

- Fig. 1 Site Plan
- Fig. 2 Regional Geology Map
- Fig. 3 Regional Landslide Map
- Fig. 4 Fault A-P Rupture Map
- Figs. 5-8 Geo Boring Logs
- Fig. 9 Plasticity Chart
- Fig. 10 Foundations / Retaining Walls on Piers
- Fig. 11 Drainage Behind Retaining Walls
- Fig. 12 Perimeter Foundation Drain

GROUND MOTION APPENDIX CBC 13 SECTION 1613 SPECTRAL PARAMETERS  
GUIDE SPECIFICATIONS FOR DRILLED-CAST-IN PLACE PIERS  
GUIDE SPECIFICATIONS FOR DRAINAGE

**DISCLAIMER**

Work was performed to normal engineering practice standards. Undiscovered conditions are possible and would require updated engineering recommendations. No warranty is presented or shall be presumed. Report is for explicit use by client. The geotechnical entity to review the plans and inspect construction shall be the geotechnical consultant of record responsible to verify / update the recommendations of this report as appropriate.

## PROJECT SCOPE AND SITE DESCRIPTION

Project description is based on the October 15, 2016 onsite meeting with the project owner and emails. It is planned to construct a new single family house on this trapezoidal-shaped downsloping lot. The lot is 145 ft deep, has a ~36 ft long frontage along Rainbow Court Cul-de-Sac; rear side is ~146 ft long. There are four distinct topographic situations on this site. The front involves an undulated mound of undocumented fill; the mid area is some 7:1 very gradual and is to be the building pad, then there is 3:1 slope some 20 ft long then there is the top of a long slope down to the Ward Creek few hundred feet away. The existing driveway approach would be the access to a short driveway. The garage is to be attached to the front side of the house. The site walkthrough mapping clearly indicates the presence of a mound of fill placed in the front lot area; this fill is undulated, does not appear to be part of the subdivision grading; and is therefore, considered to be an undocumented fill. The house will be a two-level structure. A pier-supported structural retaining wall would be needed in front to support the edge of the driveway. It would be most appropriate to support the driveway on a bridge-type structural decking. The new home would be sited on the gradual area in the middle of the lot as shown on the subdivision plan plate 5 of the geotechnical report for the subdivision, dated November 1989. Foundations are anticipated to be piers / grade beams.

## REGIONAL GEOLOGY

### ENGINEERING GEOLOGY Rainbow Court, Hayward

#### **Site Description**

The site is a vacant parcel, located at the end of the cul-de-sac of Rainbow Court, situated in the northern portion of the Hayward hills, near the campus of Hayward State College. The property is located at the top of the moderately steep natural slope above the channel of Ward Creek. Topographic data from the City of Hayward online GIS map indicates that the creek channel flows at an elevation of 370 feet, while the site is located at an elevation of about 570 feet.

An area of undocumented fill up to about 6 feet thick, extends about 20 feet from Rainbow Ct Cul-de-Sac and into the site, as indicated on the Site Plan, Figure 1. Shallow erosion and slumping about 1 to 2 feet thick are present along the front slope of the fill area. Fragments of concrete, asphalt and other construction debris can be seen on this slope, and similar fragments were observed in Exploratory Boring B. The natural, undisturbed ground surface with a gentle inclination extends about 50 feet beyond the base of the fill slope, to the edge of a dense forest which contains many bay trees, along with scattered oak and buckeye trees. The slope under the trees gradually becomes steeper, and extends about 200 feet beyond the site down to Ward Creek. The topographic data indicates that the inclination of the slope is about 1.7 to 2.0 horizontal to 1 vertical.

#### **Field Reconnaissance**

On October 22, 2016, Michael Carey CEG visited the site and walked down the entire natural slope below the property, to the lower Ward creek channel. The geologist observed the natural conditions, and looked for indications of recent or older slumping or erosion. During this slope traverse, we took several photos to record our observations. The slope appears to have an inclination of about 2:1 (horizontal to vertical, consistent with the inclination measured from the topographic data. Large, mature trees cover the entire slope, so that the ground surface is not visible in aerial photographs. The soil is composed of fine sand with minor clay, it was granular and not cohesive; damp soil does not stick to the boots, even after a recent rainfall.

There is no indication that active slumping or erosion is occurring on this relatively steep slope. This is probably because the abundant tree roots help to hold the ground; also water from natural rainfall is dispersed over the tree leaves and the leaf litter on the ground. We observed that one or two large bay trees had tilted over in the past, and the living branches were now growing vertically from the horizontal trunks. The root balls had been exposed, but no erosion had occurred there.

Near the base of the slope, the geologist observed an arcuate shaped oversteepened area about 10 feet high and 30 feet wide. The geologist interprets this as an old landslide scar. Several large trees, and one old stump are present on this steep slope. These must have grown there after the slide occurred, so the trees indicate that the feature is fairly old. No bulge or deposit is apparent on the slope below the scarp the soil probably moved off downslope into the Ward creek, and did not accumulate on the slope. No recent erosion has developed on this portion of the slope, suggesting that concentrated water has not flowed over the area. This feature is some 150 ft beyond the site.

### **Bedrock and Faulting**

Bedrock underlying the site is mapped as marine sandstone and siltstone of the Knoxville formation (Late Jurassic to Early Cretaceous ~60 Million years old). These sedimentary rocks were laid down in an ancient marine basin, and then later uplifted and folded, and broken by ancient tectonic forces associated with the movement of the North American continent. Later, these rocks were further broken and faulted by active movement of the Hayward fault and subsidiary fault traces. Ellen and Wentworth (1995) describe the rocks as thin to thick-bedded shale and fine-grained sandstone. The rocks are moderately hard when unweathered. Recent published geologic maps of the Hayward Quadrangle (Crane, 1995, Graymer 2000 and Dibblee, rev 2005 , Figure 2) indicate that beds generally trend strike to the northwest and dip steeply to the northeast.

Graymer (2000) maps a faulted lithologic contact approximately 300 feet east of the site, while Crane (1995) and Dibblee (2005) map the inactive Chabot Fault approximately 600 feet southwest of the site. The main active trace of the Hayward fault is mapped approximately 0.9 miles to the southwest (Lienkaemper, 1992, 1996); refer to the State A-P Fault Map , Figure 4. Other major active faults in the vicinity of the site include the Calaveras Fault, mapped approximately 7.1 miles to the northeast and the Concord Fault, mapped 19 miles to the north. The famous San Andreas Fault is mapped 19.3 miles to the southwest. Like the entire Bay Area, the site may be subjected to moderate to severe ground shaking in the event of a large earthquake on any of these faults, or another local active fault.

The photo interpretative slope stability maps of Nilsen, (1975) , Figure 3, and Majmundar, (1995) show that no landslides are mapped on the steep slopes above Ward Creek (see Figure ---). The relative stability of these slopes is probably due to the sandy, dense bedrock underlying the area. Significantly more landsliding often occurs in areas underlain by softer, clay-rich bedrock. Additionally, minor slope features such as small slides, are obscured by the thick tree cover.

### **Discussion and Conclusions**

The published geologic and slope stability maps of the area indicate that the site is underlain by generally dense, well-consolidated, sandstone bedrock, and that landslides are rare in the area, even on the steep slopes above Ward Creek. Therefore, based on this data, development of the planned new house is considered to be feasible, as long as the following recommendations are carefully followed.

Although there is no evidence of recent erosion on the slope, it is possible that future erosion or slumping near the house could be caused by natural events such as tree falls or extremely heavy rainfall. Therefore, the planned house should be founded on structural piers, secured into the firm bedrock. The foundation piers should prevent movement or settlement of the house, while the natural slumping can be repaired.

Proper control of surface water is an important consideration during the design and construction of the house. Concentrated surface water from the roof or surrounding landscaping must not be allowed to be discharged over the slope. Water from the roof should be taken to the paved street, while water runoff from the lower landscaping / shallow foundation sub-drains should be taken to disposal locations approved by the Engineer.

## GEOTECHNICAL INVESTIGATION . CONDITIONS

- The geotechnical engineer walked through the site and vicinity to map geo outcrops and pertinent site conditions. Also, the geotechnical engineer reviewed regional geologic / landslide maps (Figures 2 & 3 ) and the Fault Hazard A-P Map (Figure 4). The site is outside hazards indicated by such Maps.
- The geotechnical engineer reviewed the geo data from the supplementary subdivision report of November 1989. Borings # 14 and # 15 were made at the boundary of this Lot 5 ( # 2367 Rainbow court). Therefore, the geotechnical exploration plan was to supplement this data by exploring the rear side fronting the downslope and the front driveway/garage side.
- The geotechnical engineer commissioned the excavation and logged geo exposures in two geo exploratory borings, located as shown on the Site Plan, Figure 1. Boring A was a primary boring located downslope , fronting the long rear downslope; whence Boring B was located @ the front driveway/garage area. All together , the four borings , #14 & # 15 from the subdivision and A&B from this work ,reasonably define the geo profile prevalent at this property to support geotechnical engineering recommendations. The geotechnical engineer logged and classified the encountered geo materials in accordance with ASTM D 2487 –CBC 13 Section 1803.5.1. The engineer also performed in-field tests on the brass liner core sample tubes. The logs of all four geo exploratory borings are shown on Figures 5-8 .
- The borings were sampled and liner tube core samples ( 2” ID) were retrieved . The sampler blow counts were converted to the SPT s of ASTM D1586 N-60 , per US Bureau of Standards work by Kovacs et al 1983 (references).The data from the borings were utilized to generate the geo profile of the site in order to guide project engineering .
- The geo profile is as follows : There is generally consistency in the subdivision borings # 14 & #15 and Boring A. The upper geo material is native silty Clay CL-ML to clayey Silt ML-CL , which is shallow 2.5 to 4 ft thick and is slightly expansive ( CBC 13 Section 1803.5.3 Item # 1 classification as non-expansive);Figure 9. silty Clay CL-ML is underlain by Cretaceous silty Sandstone bedrock that is very indurated and competent.  
  
Boring B , drilled in the front to explore the driveway area, disclosed fill material , mostly clayey Silt ML-CL with rocks in sizes 1’ to 4”. This undocumented fill appears to be non engineered , 3 ft to 4 ft thick and is likely was placed subsequent to the subdiviGeomorphic mapping indicates this mound of fill Qaf covers the entire Cul-de- Sac frontage of this lot.
- No groundwater was encountered.

## CONCLUSIONS

Based on review of the aforementioned geotechnical and geologic exploration material as well as assessment of the data in consideration of the proposed project, the following conclusions are drawn pertinent to geotechnical issues:

- **The project is feasible from the geotechnical engineering perspective.** No earthquake faults that would preclude or, severely constrain the project are present. The recommendations of this report and conclusions shall be followed in the proposed project planning, budgeting, and for the design/plans and construction.
- Groundwater while was not encountered but perched storm water shall be considered to occur @ shallow depths; Foundation installation, in particular the drilling of pier shafts are to be undertaken in clear weather.
- The surface and near surface soil is classified as Slightly expansive CL-ML CBC 13 Section 1803.5.1 designations; referenced **CBC13 Sec 1803.5.3 Item # 1.**
- The settlement potential under the light building loadings is negligible under normal service loadings.
- The site maps outside the state of CGS SHZ-SHMA earthquake liquefaction hazard zone. Therefore, no particular vulnerability of the underlying geo materials is indicated. Also, the site is outside areas of historic regional large-scale landslides. The site overall topographic relief is moderate and does not lend itself to outstanding slope stability concerns. The landslide mapped by the geologist on the long downslope, is some 200 ft beyond the property.
- Strong ground motion is to be accounted for by the **CBC 13**, as applicable, Section **1613.3** stipulations to the designated Site Class and Seismic Design Category.
- Appropriate **drainage-control** measures should be developed around the building area. This would require a shallow perimeter subdrain to avert surface water intrusion underneath the grade-beam to subgrade contact and resulting ponding or standing water into the crawl space. also interception and disposal of storm runoff from the driveway shall be clearly a consideration to project planners. Proper disposal of roof runoff shall also be directly piped to the Cul-de-Sac curblin, not to impact the slopes or cause undue erosion.
- Foundation and retaining walls recommendations require pier and grade beam foundations. The piers are to be secured into the underlying coherent Kp Sandstone bedrock. The piers shall account for slope downhill creep lateral forces. The rearmost pier row fronting the long downslope shall be provided with additional rebar

## GEOTECHNICAL RECOMMENDATIONS (DESIGN LEVEL)

### 1. BUILDING FOUNDATIONS PIERS.DRILLED.CAST IN-PLACE

It is most appropriate to support the building on drilled cast-in-place structural concrete piers, well secured into the underlying coherent cretaceous Kp Sandstone Bedrock. The piers shall be designed for:

- Vertical building loads per structural engineer
- Lateral retaining walls forces
- Slope lateral geo creep force.
- Any mandated earthquake forces

The design parameters for the piers are depicted on Figure 10. Design parameters include both allowable vertical shaft friction along the shafts of the piers and allowable lateral bearing; both require discounting of all materials above the coherent Kp Sandstone bedrock from pier capacity assessments. Pier tip bearing support is to be discounted. In the unexpected situation of hard refusals (unlikely for this project) then the geotechnical engineer is to be consulted for additional revised recommendations. The uplift pier capacity shall be presumed to be same as that for down loadings.

It would be appropriate to design/install 18" diameter piers on typical spacings of 5 ft to 8 ft OC as designated by the project structural engineer. The group action factoring per CBC 13 section 1803.5 would be inconsequential in coherent bedrock that does not rely much on load bearing spread out to mobilize passive / shaft support.

The design of such piers to resist lateral loads shall be per CBC 13 Section 1807.3.2.1 as applicable; the use of unconstrained formula is more conservative where the piers are restrained by caps or other means. Other equilibrium-based formulas can also be used where well-substantiated. Should it be desirable to check deflections, LPILE finite difference computer code or similar techniques may be utilized. Grouped piers are to share the lateral loads by action of the grade beam. The geotechnical engineer may need to be consulted during the plan/design development stage for additional recommendations depending on the particulars of the piers deployment and location.

The grade beam shall be designed to provide integrated foundation group action. The beam shall be of reinforced concrete with minimum # 5 rebar cages. As the subgrade is classified to be only slightly expansive, CBC 13 Section 183.5.3 Item # 1, there would be no need to leave in an under GB to subgrade void which normally is needed to absorb uplift from expansive subgrades from impacting foundations. Typically, the underside of the grade beam is not water tight and perimeter water runoff intrusion may occur into the crawl spaces. Therefore, the utilization of a perimeter foundation subdrain, such as the detail of Figure 12 is recommended. This would be in addition to proper control of surface runoff.

All pier shafts shall be maintained free from fall-ins. The contractor need not anticipate the encounter of rock floaters and cobbles; groundwater is not anticipated in good



weather. No hard drilling refusals are anticipated but, the sandstone bedrock may cause slower drilling at some depths. The open pier shafts shall remain stable for a few days in good weather without the need for casing. Once the pier shafts pass inspections and the cages are placed in the open shafts, the shafts shall be backfilled with structural concrete shortly thereafter, to avoid cave-ins which would be complicated to clean up once the cages are in.

The contractor shall survey locate the pier centers fairly accurately to coincide with the center of the grade beam and avoid concentrically loaded piers. Concentric loadings would require engineering consultations to resolve the load transfer.

The contractor should cover the shafts with plywood plates till the rebar cages are inserted and the shafts are backfilled with structural concrete.

Surplus pier cuttings shall be hauled away and may not be tossed onto this sloped site.

## 2. RETAINING WALLS

We anticipate that the driveway edge at the garage would require a retaining wall some 5 ft to 7 ft tall. This wall would be supporting the edge of a driveway bridge structure designed to bridge over the mound of undocumented fill in front of the property. Construction of the bridge structure would make unnecessary to over-excavate and re-compact the mound of undocumented fill. The wall ends may have to be winged to U-shaped plan alignment to contain the undocumented fill against laterally spreading out.

Retaining walls should be designed for the lateral pressures due to the retained earth and all other surcharge conditions that may occur at the top of the wall. Recommendations for lateral earth pressures and some surcharge conditions are presented herein. For this site and considering the local geo materials and prevalent upslopes topography, a standard 80 pcf Static lateral design basis shall be appropriate; seismic geo and structural loads are additive. This complies with CBC 13 Sec 1610 and Table 1610.1 for structural non-deflection (at-rest) building foundation retaining walls. This rated lateral load criteria accounts for the undocumented fill which would exert more than normal geo lateral loads. The geo parameters for the design of site walls are shown on Figure 10 for the contemplated pier-supported retaining walls; also referenced Figure 11 for drainage / waterproofing behind retaining walls.

The resistance to lateral loads is generated by support from the cast-in-place structural reinforced concrete piers action.

The overall stability of the retaining walls shall be demonstrated by the structural engineer. A suitable factor of safety against Sliding should be incorporated into design; CBC 13 Sec 1807.2.1 and 1807.2.3. The overturning moment may be resisted by coupling the piers or, qualifying the piers for combined lateral load and moment atop of the pier scenario. Bearing is implicitly addressed in the shaft support calculations.

**All Construction joints shall be properly sealed with approved waterstops.**

### **Seismic Geo Lateral Earth Pressures**

For the anticipated ground motion per attached Ground Motion Appendix ( based on CBC 13 ), a value of 15 pcf inverted triangle based on M-O method would be appropriate to simulate the ground inertia onto the retaining wall system. While strictly applying the PGA of 1.0 g from the CBC based Ground Motion Appendix would result in higher inertia values ( site is ~ 0.6 miles from the Hayward Fault) however, in consideration of the upgraded design for non deflection and the application of traffic surcharge , the cumulative load combination would justify the recommended value.

The choice to apply seismic design criteria to retaining structures stems from engineering due diligence and also in reference to CBC 13 Section 1803.5.12 . In this regards , the building code applies the criteria to walls greater than 6 ft in height and depending on the risk- based seismic design category.

For displacement analysis of critical tall retaining structures subject to earthquake loadings , the project planners should further consult the geotechnical engineer. For typical structural walls designed for only static loading conditions and of ductile construction, nominal yield acceleration is implied. Where earthquake peak ground acceleration exceeds these values, damage can occur to the wall that may require minor to major repair or replacement. Damage levels can be measured by permanent plastic lateral deformation of wall due to earthquake loads.

### **Lateral Pressure Due to Surcharge (Traffic onto the Driveway Bridge) Loads**

Additional lateral pressure(s) on walls due to surcharge loads applied to the retained earth, such as due to adjacent foundations CBC 13 section 1809.6 , traffic or equipment loads should be considered, in addition to the loads on Figures 9. The geotechnical engineer should be retained to analyze these surcharge loads.

Basic loads are presented on Figure 10.

### **Subdrains**

The active pressures given in this section assume that subdrains will be constructed behind the retaining walls to prevent the buildup of hydrostatic pressure. A typical section illustrating subdrainage construction is presented on Figure 11. It is noted that this detail provides guidelines for both moisture and waterproofing treatments

and it is recommended that moisture prevention/waterproofing specs be incorporated into the design of all retaining walls, where water intrusion, and/or moisture onto the wall would be unacceptable .

All retaining walls building and site , should be provided with a subdrain behind the wall stem to minimize the buildup of hydrostatic pressure. This is an downsloping site and effective control over water surface and subsurface is mandated. A typical subdrain system may consist of a perforated pipe surrounded by filter material, or other approved devices. Perforated pipe should be schedule 40 or equivalent (SDR 35 acceptable ), as a minimum.

Flexible, corrugated piping is not recommended due to its higher crush strength. The sub drainage may be a Mirafi 6000 grade blanket with some Caltrans class 2 perm material or alternatively, drain rock with fabric.

**For the upslope driveway retaining wall alongside the building it would be desirable to lower set the subdrain below the pad, even if a separate trench is needed.**

Filter material should be wrapped with a geotextile filter fabric to prevent infiltration of fines and clogging of the system. Filter material may consist of 1/2 to 3/4-inch uniform crushed rock or gravel per linear foot, wrapped 'burrito' style with geotextile filter fabric. Subdrain pipes should be installed over a minimum 4-inch bed of gravel. The pipe should be oriented with perforations facing downward and sloped at a minimum gradient of 2 percent. The geotechnical engineer should observe the installation of subdrains. Subdrains should maintain a positive flow gradient away from the back of retaining wall and outlets should discharge in a non-erosive manner. The subdrain should also be constructed in accordance with the appropriate section of the attached "**Guide Specifications for Subsurface Drains**" and the attached Figure 10. This requirement also applies to foundation grade beam where grade change across the grade beam is 3 feet or greater.

It should be pointed out that the recommended subdrainage is not intended to provide water or moisture proofing to the walls, but only to relieve hydrostatic pressure. Therefore, where moisture seepage or efflorescence on retaining walls is not desired, or in any below grade area, the retaining wall should be waterproofed in addition to being subdrained. As a geotechnical guide, use Bituthene/Liquid Boot as approved by project AIA refer to **Figure 11; CBC 13 Dampproof/waterproof referenced; Section 1805.2 and 1805.3**

### **Backfill**

Backfill behind earth retaining structures may consist of 3/4-inch maximum diameter rounded to subrounded gravel vibrated in place. If soil is used for backfill, mechanical compacting methods will be necessary to obtain a relative compaction of **at least 90%**. This spec is based on the local geo **materials make up of predominantly SILT ML – CL**. Backfill directly behind earth retaining structures should not be compacted by wheel, track, or other rolling by heavy construction equipment unless the wall is designed for the surcharge loading from the compaction equipment and the wall is allowed to cure for a long enough time to

Avoid heavy compaction grading equipment to compact backfills immediately behind retaining walls; heavy equipment loads could exceed the design service loads of the retaining structure. Also the backfill should be scheduled based on the attained structural strength of the concrete.

### 3. GRADING

Grading is anticipated to be very minimal for this project; involving general clearing of the primitive landscaping improvements and contouring the ground to drain away from the building area. In case project planning involves any structure grading, such as placement of additional fills or, subgrading to re-compact subgrade underneath Concrete Slabs constructed on grade. Such work should be undertaken under the observation and with the approval of the geotechnical engineer, and may require further geotechnical consultations. The building pad shall be firm and proofed by the construction equipment; any refuse or weak subgrade conditions should be brought to the attention of the geotechnical engineer for additional recommendations.

Graded pads, including the stepped-down tiered pad should be protected from traffic or erosion until permanent structural improvements are constructed. Any lapse between pad grading and foundation work may require a tarp to protect the freshly graded pad. Slope all finish grades to drain away from the **foundation line, CBC 13 Sec 1804.3 & 1808.7.4. ALL permit grading shall be undertaken under the auspices of the geotechnical engineer, in accordance with the project plans /specs and the attached "Guide Specifications for Engineered Grading". Survey grade set and control shall be undertaken properly.**

**Wet weather construction** shall comply with City Ordinance for Wet Weather and would require further geotechnical guidance.

### 4. GEO EARTHQUAKE CONSIDERATIONS

Seismic considerations are generally: ground-surface earthquake fault rupture, ground motion, ground performance and structural factors. These are reviewed in the following: surface fault rupture.

#### **Earthquake Fault Zones-Surface fault Rupture**

The site is not traversed by any known active fault, is outside the Alquist-Priolo Earthquake Fault Zones, and is therefore, not subject to primary seismic geologic hazards of surface-fault rupture. The site is about ~0.6 miles (~1.0 km) east of the S segment Hayward Earthquake Fault System; Figure 5. For compliance with the **California Building Code CBC 2013 Sec 1613.3**, refer to the attached Ground Motion Appendix.

The purpose of the earthquake provisions presented in the California Building Code is primarily to safeguard against major structural failures, collapse, and loss of life, not to limit damage or maintain function, except for essential facilities; seismic risk Category IV. Based on that purpose, the subject development may be designed in accordance with the seismic formulas and requirements presented in the current version of the California Building Code, seismic Risk Table 1604.5

**Ground Performance.....**

The site maps outside the State SHZ-SHMA liquefaction green zone of the regulatory map and therefore, no flag is raised as to the regional vulnerability of the site to experience liquefaction-prone impacts. Additionally, the site-specific geo exploration did not encounter saturated sand / silts that could be vulnerable to such impacts.

**Ground Motion**

Considering regional geologic factors and earthquake faults, strong ground shaking should be anticipated throughout the service lifetime of the project. This is mostly a regional and vicinity exposure condition. Seismically induced ground motion should obviously be anticipated. Much of the motion exposure would likely be the result of the regional S segment Hayward Fault System, which is anticipated to generate ground acceleration ~1.0 g, in the event of a credible earthquake with a moment magnitude Mw of 7 or so. Soft soils that could amplify far field events ( **Cypress Fwy, Loma Prieta 1989**) are **NOT present** at this site. The site class of the **Ground Motion Appendix** was selected to meet the intent of the CBC 13 sec 1613.3; Class B is appropriate, as firm Kp Sandstone bedrock is within 3ft to 4 ft from grade. Attached Ground Motion Appendix.

**5. DRAINAGE: AREAL SITE .SUBSURFACE**

All roof spouts shall be hooked up and piped to approved outlet destinations (See below). The building pad is to be proof graded (surficial minor grading) to sheet-flow runoff away from the foundations and improvements. Refer to attached Drainage Guide Specs.

The finished site drainage in unpaved areas should include a minimum positive gradient of 5% away from the structure for a minimum distance of 5 to 10 feet in a non-erosive manner. Drainage over paved surfaces should have a positive flow gradient @ min 2%. **CBC 13 Sec 1804.3& 1808.7.4**

All roofs and canopies should be provided with eave gutters and down spouts that lead into non-perforated (solid) pipes that should be collected in drainage devices. All drainage devices should conduct drainage in an engineered non-erosive manner (the surface clayey silts are erodible) to an approved point of discharge destination (see below). All drainage off the property should be accomplished in an approved manner to prevent erosion or instability.

It is strongly recommended to install perimeter foundation subdrain on this site, to intercept hillside runoff for upslope frontage of building as well as the sides; refer to

Figure 11; refer to CBC 13 Section 1805.4.2. This site lies on a hillside, a setting that receives significant hillside runoff, both surface and subsurface. This requirement is to avert intrusion of surface runoff in the vicinity of the foundation grade beam, through the grade beam to subgrade contact, that would result in standing water in the crawl space beneath the building. The building side of the subdrain shall have a water barrier such as a durable asphaltic felt sheet or a Miradrain 2000 grade blanket to be draped into the grade beam- to- subdrain trench side interface.

The requirement for a perimeter subdrain would be implicitly met on the upslope Cul-de-Sac side where the upslope driveway retaining wall is present and is equipped with a subdrain. The subdrain pipe shall be set below the crawl space elevation to assure of required interception.

#### **Runoff Disposal :**

**Roof Runoff :** All roof downspout water shall be piped to the Cul-de-Sac curbside and shall not be outlet on the site.

**Sub Surface Drains (Perimeter and retaining wall) :** Subdrains runoff is to be dispersed per multiple outlets on the rear lower slope within this site. The volume of this component of runoff is very small compared to the Roof Runoff component.

The disposal plans are to be pre approved, setbacks and erosion control are required. Erosion control shall include the placement of a fabric and gravel at the discharge pipe outlet; the discharge pipe shall have a T-end.

## **6. DRIVEWAYS AND GARAGE**

Grading to prepare the site for these improvements should be minimal, as outlined previously under the Grading Section. It would be most appropriate to build both the driveway and garage floors as decking to a pier-supported bridge structure. The piers shall be secured into the indurated Kp Sandstone bedrock which underlies the undocumented fill; discounting the weathered top of the Kp bedrock. The piers design shall be pursuant to the geotechnical requirements of Figure 10. The driveway edge is to be supported by a structural cast-concrete retaining wall, designed per requirements of Figure 10. The retaining wall shall be provided with engineered sub-drain per specifications of Figure 11. The sub-drain disposal shall be as stipulated by Section 5 of these recommendations.

Runoff from the hardscape ( driveway, walkways, patios etc ) is to be collected and controlled and not be allowed to sheet flow onto the slopes.

## **7. PLANS REVIEW AND CONSTRUCTION SPECIAL**

### **INSPECTIONS. TESTING**

As the plans and design development proceeds, the design team may need further geotechnical consultations for clarity and for special situations. The geotechnical

assessments of this report should be a planning consideration and be accounted for in the construction of this project.

Plans and construction should be undertaken with geotechnical engineering consultations. Foundations, retaining walls details / calculations and site development plans shall be reviewed by the geotechnical consultant for compliance to pertinent aspects of the project construction.

Construction of geotechnical pertinent aspects of the project shall also be inspected by the geotechnical engineer. The drilling of foundation pier shafts / backfill behind retaining walls pad tiered grading and any old fill subex compaction require geotechnical special inspections / testing in compliance with CBC 13 Tables 1705.6 and 1705.8.

Wet weather construction requires City permit and would entail further geotechnical guidance to control runoff and silt transport / erosion. No silt transport from the construction activity shall occur onto the rear long downslope to the Ward Creek riparian watershed.

### NOTICE

The conclusions and opinions in this report are based on the test borings that were made on the site, spaced as shown on the Site Plan, Figure 1. While in our opinion these borings adequately disclose the soil conditions across the site, the possibility exists that anomalies or changes in the soil conditions that were not discovered by this investigation could occur between borings. Should such items be discovered during construction, our office should be notified immediately that any necessary supplemental recommendations can be made.

This study was not intended to disclose the locations of any existing utilities, septic tanks, leaching field or other buried structures. The contractor or other people working on the project should locate these items, if any.

Unless otherwise stated, the contract for this report excluded evaluation of corrosion potential of the soil, the presence of sulfates or chlorides in the soil, and other chemical substances that could impact utilities or structural concrete.

This report was prepared to provide engineering opinions and recommendations only. It should not be construed to be any type of guarantee or insurance.

### REFERENCES

#### **Geotechnical Engineering**

Bowles, Joseph E.: "Foundation Analysis and Design" McGraw-Hill Book Company, 1977.

Bowles, Joseph E.: "Physical and Geotechnical Properties of Soils" McGraw-Hill Book Company, 1979.

Kovacs W. D, Salmone, L.A. and Yokel F. Y. (November 1983), "Comparison of Energy Measurements in the Standard Penetration Test Using the Cathead and Rope Method." National Bureau of Standard Report to the U.S. Nuclear Regulatory Commission.

Marcuson, W.F. III, and Bieganousky W.A., Laboratory Standards Penetration Tests on fine Sands," Journal of Geotechnical Engineering Division, ASCE, Vol. 100, No. GT6, June, 1976, pp. 656-588

Duncan J.M. and A.L. Buchignani ,June 1976, An Engineering Manual for Settlements Studies, Department of Civil Engineering, Institute of Transportation and Traffic Engineering, University of California, Berkeley.

Duncan J.M. and A.L. Buchignani ,March 1975, " An Engineering Manual for Slope Stability Studies", Department of Civil Engineering , Institute of Transportation and Traffic Engineering, University of California , Berkeley.

Geotechnical Engineering ,Inc (GEI), "Report, Supplementary Investigation , Proposed Residential Development ,Parkside Drive & Rainbow Court, Tract 3992 ,Hayward ,California"; Dated November 2 , 1989 , Job No. 110817.

### **Engineering Geology**

Crane, R.C. 1995; Geology Of Mount Diablo Region And East Bay Hills. in: Recent Geologic Studies of the San Francisco Bay Area, SEPM, Pacific Section, Vol. 76, p87-114

Dibblee, T.W. Jr. 2005; Geologic Map of the Hayward Quadrangle, Alameda and Contra Costa County. Dibblee Foundation Map DF-163 (edited by John Minch).

Graymer, R.W., 2000; Geologic Map and Map Database of the Oakland Metropolitan Area, Alameda, Contra Costa and San Francisco Counties, California, U.S. Geological Survey MF 2342

Lienkaemper, J. 1992; Map Of Recently Active Traces Of The Hayward Fault, Alameda And Contra Costa Counties, California. U.S. Geological Survey Miscellaneous Field Studies Map MF 2196

Lienkaemper, J.J., 2006, Digital database of recently active traces of the Hayward Fault, California: U.S. Geological Survey Data Series 177, available online at <http://pubs.usgs.gov/ds/2006/177/>.

Majmundar, H. 1995; Landslide Hazards In The Hayward Quadrangle and parts of the Dublin Quadrangle, Alameda And Contra Costa Counties, California. CDMG Landslide Hazard Identification Map No. 37

Nilsen, T.H., 1975; Preliminary Photointerpretation Map of Landslide and Other Surficial Deposits of The Hayward Quadrangle. U S Geological Survey, OFR 75-277-19





0 10 20 30



Scale Feet

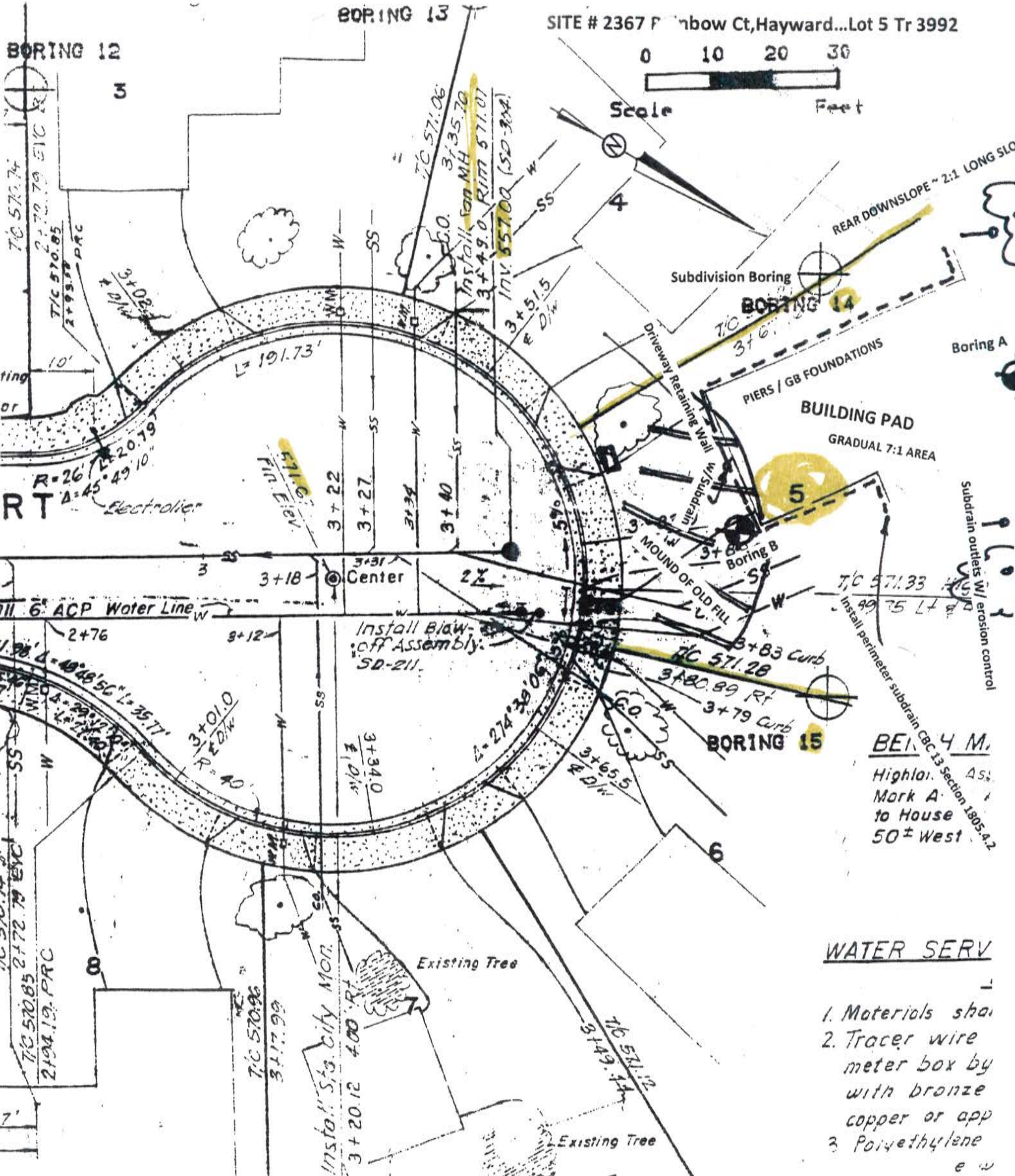

BEI 4 M.  
 Highl. AS  
 Mark A  
 to House  
 50± West

WATER SERV

1. Materials sha
2. Tracer wire meter box by with bronze copper or app
3. Polyethylene

**PLAN**  
 Job No.

**GEOTECHNICAL ENGINEERING, INC.**  
**HALLENBECK / ALLWEST ASSOCIATES**  
 PLATE 5

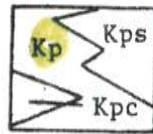

Panoche Formation  
(marine)

Kp; clay shale, gray, micaceous, argillaceous to silty, minor thin sandstone beds,

Kps; sandstone, tan, hard, arkosic, locally contain large concretions, some interbedded clay shale

Kpc; conglomerate composed of cobbles of granitic and dioritic rocks, porphyritic rocks, quartzite and black chert in matrix of brown sandstone

Upper Cretaceous

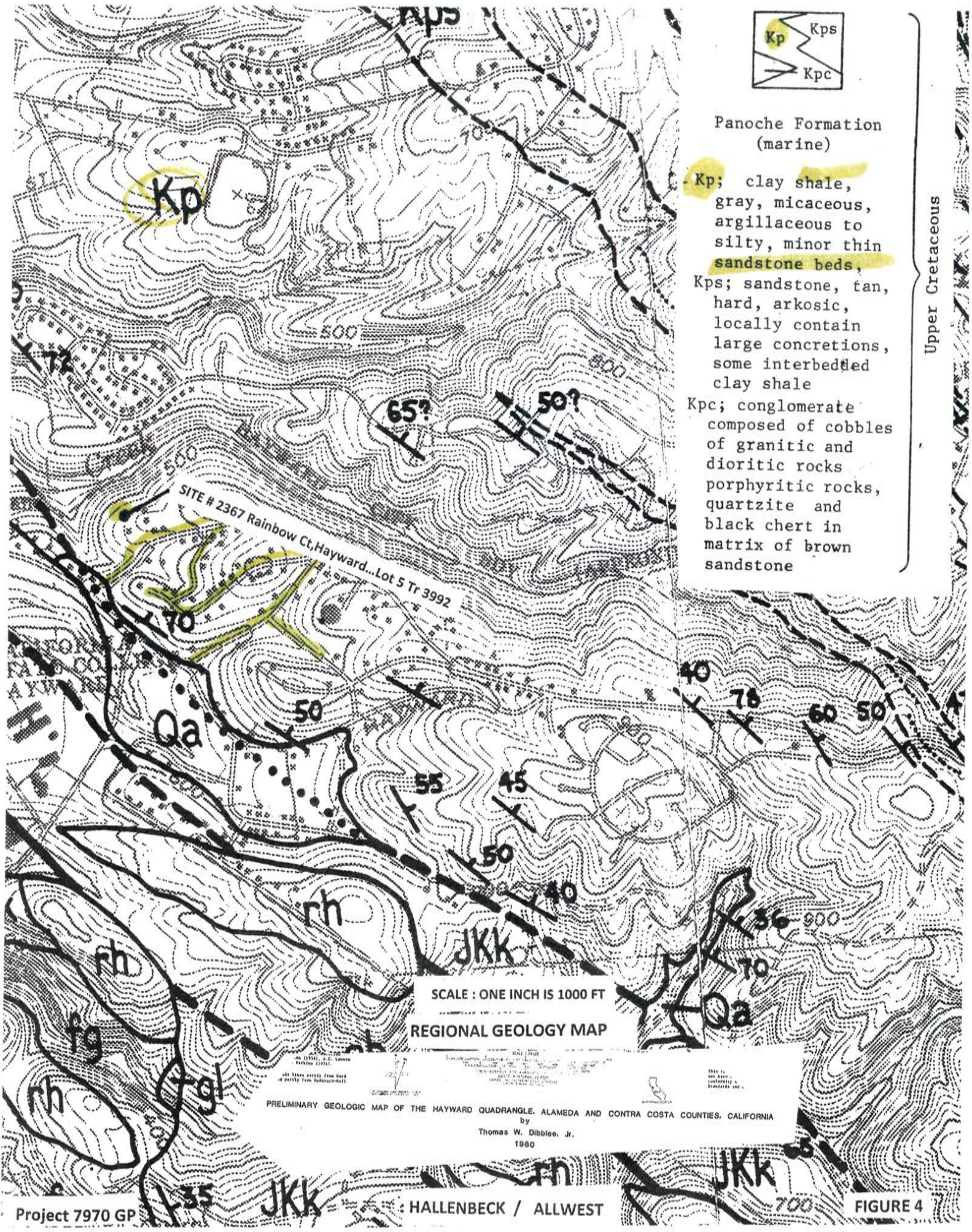

SCALE : ONE INCH IS 1000 FT

REGIONAL GEOLOGY MAP

PRELIMINARY GEOLOGIC MAP OF THE HAYWARD QUADRANGLE, ALAMEDA AND CONTRA COSTA COUNTIES, CALIFORNIA  
by  
Thomas W. Dibblee, Jr.  
1980



SITE # 2367 Rainbow Ct, Hayward... Lot 5 Tr 3992

CALIFORNIA  
STATE COLLEGE  
HAYWARD

PRELIMINARY PHOTOINTERPRETATION MAP OF LANDSLIDE AND OTHER SURFICIAL DEPOSITS OF THE  
HAYWARD 7 1/2 QUADRANGLE, ALAMEDA COUNTY, CALIFORNIA

by  
Tom H. Nisank  
1975

REGIONAL LANDSLIDE MAP.

SCALE: ONE INCH IS 1000 FT

HALLENBECK / ALLWEST

FIGURE 3

SCALE : ONE INCH IS 1300 FT

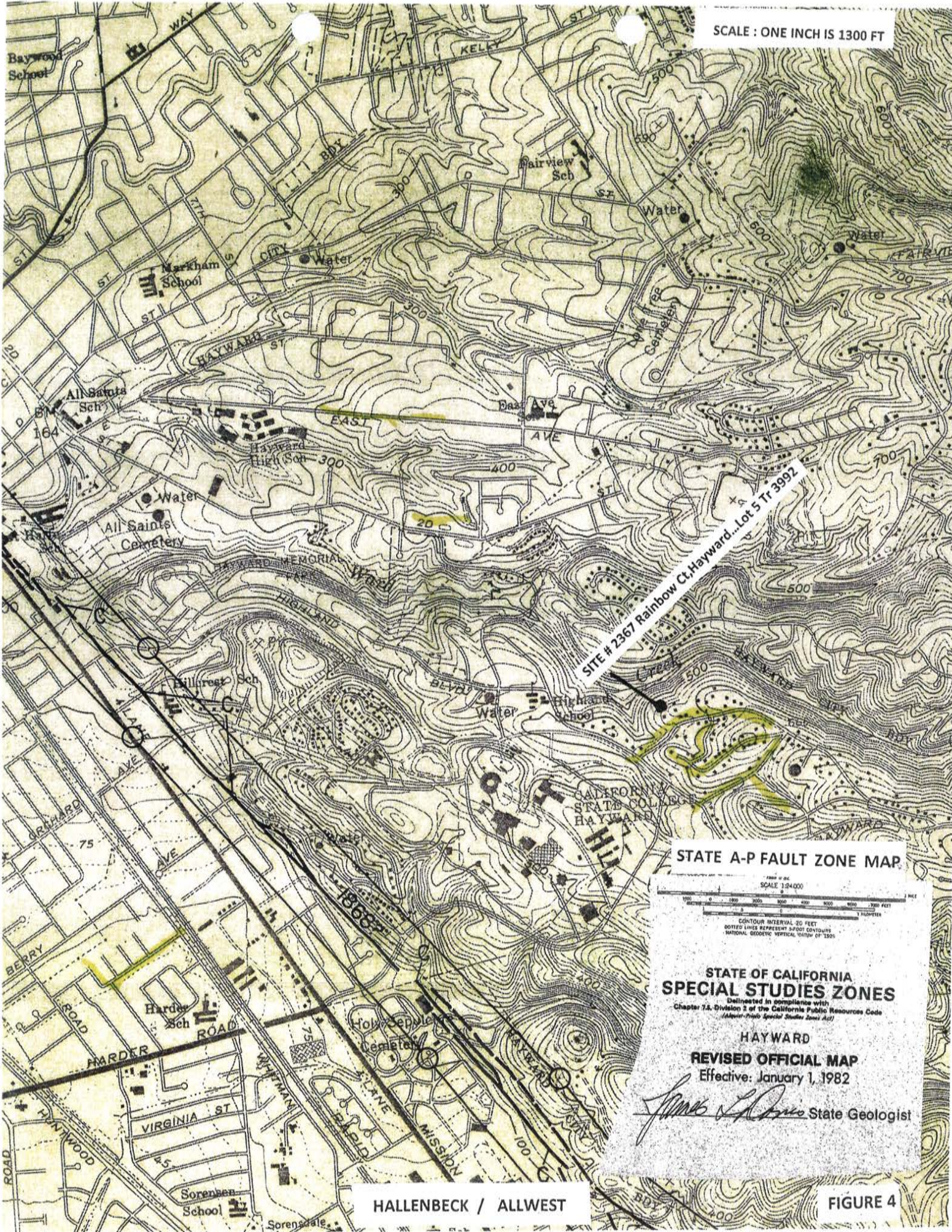

SITE # 2367 Rainbow Ct, Hayward... Lot 5 Tr 3992

**STATE A-P FAULT ZONE MAP**

SCALE 1:24,000

SCOUTOUR INTERVAL 20 FEET  
 DOTTED LINE REPRESENTS 5000 FEET CONTOUR  
 NATIONAL GEODETIC VERTICAL DATUM OF 1929

**STATE OF CALIFORNIA  
 SPECIAL STUDIES ZONES**

Delimited in compliance with  
 Chapter 7.5, Division 2 of the California Public Resources Code  
 (Alquist-Pulso Special Studies Area Act)

**HAYWARD**

**REVISED OFFICIAL MAP**  
 Effective: January 1, 1982

*James A. Payne* State Geologist

HALLENBECK / ALLWEST

FIGURE 4

**PROJECT:** SITE # 2367 Ra low Ct, Hayward...Lot 5 Tr 3992

**BORING NO.** A

**BORING SUPERVISOR:** RAM

**TYPE OF BORING:** 3" AUGER

**DATE OF BORING:** Oct 22, 2016

**HAMMER WEIGHT/DROP:** 70#/30" drop  
**TYPE:** FF

**SURFACE ELEVATION:** Gradual Area

**GROUNDWATER DEPTH: GW**

NE

**DESCRIPTION OF MATERIALS**

DEPTH IN FT.	SAMPLE	SAMPLE NUMBER- SAMPLE DIAMETER	DRIVING RESISTANCE BLOWS PER FT. (SPT)	DRY DENSITY P.C.F.	MOISTURE CONTENT %	UNCONFINED- COMPRESSION STRENGTH P.S.F.	OTHER TESTS (Field, Lab)
1		1-2"	35 (23)	92 pcf	17%	Su= 1300 psf(PP)	PI<10
2				spt	12%		
3							
4							
5							
6							
7							
8							
9							
10							
11							
12							
13							
14							
15							

Medium Stiff Brown Very Silty CLAY  
(Native) CL-ML  
Olive Brown

Kp Indurated Silty SANDSTONE BEDROCK  
Rust & Tan Cretaceous

Termination

SPT Conversion: multiply Field BPF by  
0.-60 Spt ASTM D1586  
Kovacs et al (1983)  
U.S Bureau of Standards

Soil Classification ASTM D 2487 & CBC 13 SECTION 1803.5.1

Project 7970 GP

**HALLENBECK / ALLWEST ASSOCIATES**

FIGURE 5

PROJECT: SITE # 2367 Railroad Ct, Hayward...Lot 5 Tr 3992

BORING NO. B

BORING SUPERVISOR: RAM

TYPE OF BORING: 3" AUGER

DATE OF BORING:

HAMMER WEIGHT/DROP: N/A  
TYPE:

SURFACE ELEVATION: Driveway Fill Mound

GROUNDWATER NE  
DEPTH: GW

DEPTH IN FT.	SAMPLE	SAMPLE NUMBER- SAMPLE DIAMETER	DRIVING RESISTANCE BLOWS PER FT. (SPT)	DRY DENSITY P.C.F.	MOISTURE CONTENT %	UNCONFINED- COMPRESSION STRENGTH P.S.F.	OTHER TESTS (Field, Lab)
--------------	--------	-----------------------------------	---	--------------------	-----------------------	---	--------------------------------

DESCRIPTION OF MATERIALS

Loose to Medium Stiff CL-CH PI~ 28  
Dark Brown to Brown CLAY

1

Undocumented fill Qaf w/ sharp rocks 1"-4"

2

Light Brown Clayey SILT ML  
w/rocks

3

4

000

Turns to highly Weathered Bedrock

5

6

Kp Indurated Silty SANDSTONE BEDROCK  
Rust & Tan Cretaceous

7

Termination

8

9

10

11

12

SPT Conversion: multiply Field BPF by  
0.-60 Spt ASTM D1586  
Kovacs et al (1983)  
U.S Bureau of Standards

13

14

15

Soil Classification ASTM D 2487 & CBC 13 SECTION 1803.5.1

Project 7970 GP

HALLENBECK / ALLWEST ASSOCIATES

FIGURE 6

# BORING 14

SITE # 2367 Rainbow Ct, Hayward...Lot 5 Tr 3992

Depth  
(Ft.)

6" Diameter Auger Hole

Drilled 9/27/89

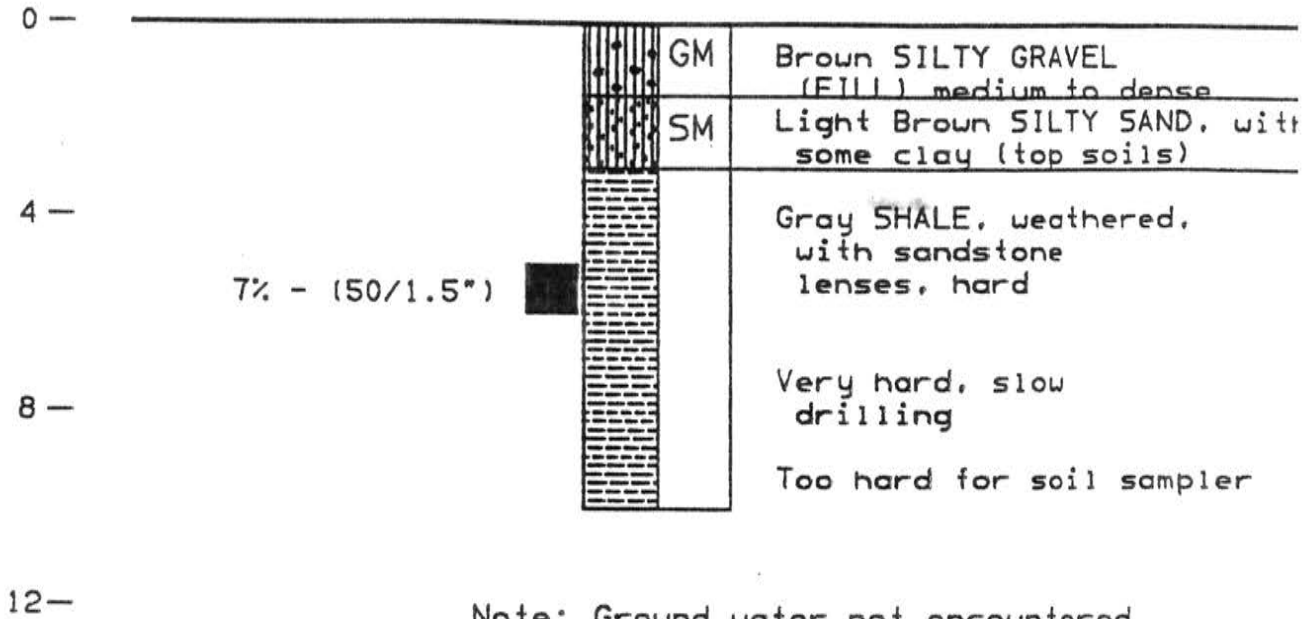

## LOG OF BORING

Scale 1" = 4'



# BORING 15

SITE # 2367 Rainbow Ct, Hayward...Lot 5 Tr 3992

6" Diameter Auger Hole

Drilled 9/27/89

Depth  
(Ft.)

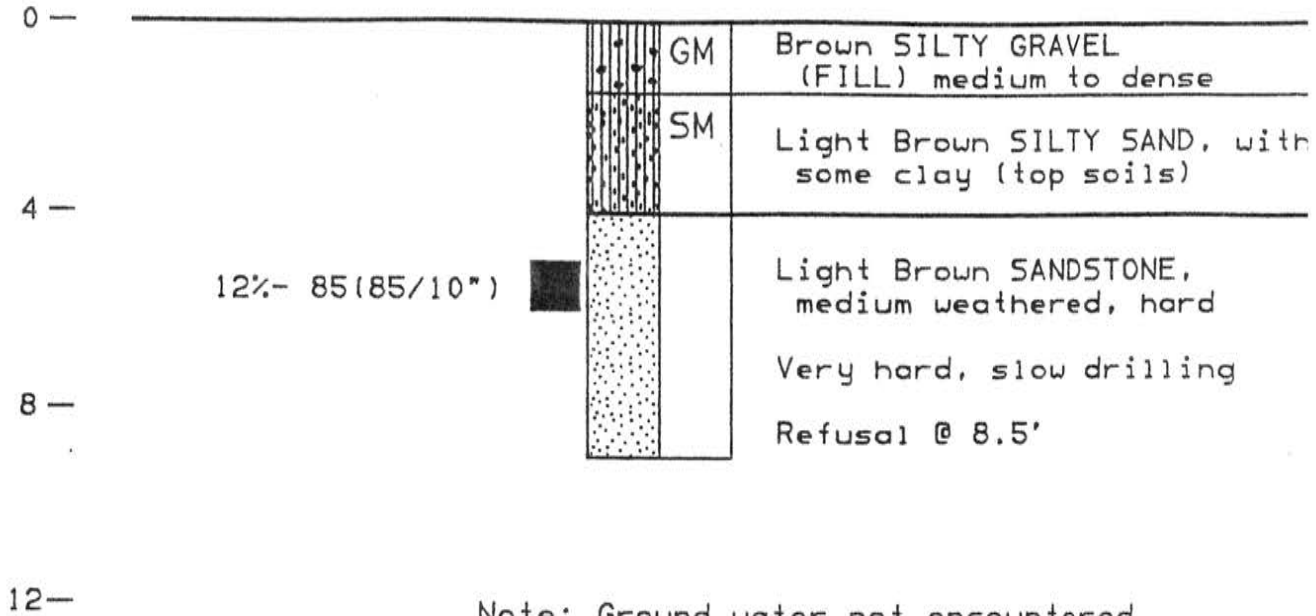

Note: Ground water not encountered

## LOG OF BORING

Scale 1" = 4'

# PLASTICITY CLASSIFICATION

per Arthur Casagrande

Remolded; only fraction passing #40 sieve, fine sand, silt, and clay fractions, coarse sand and gravel discarded

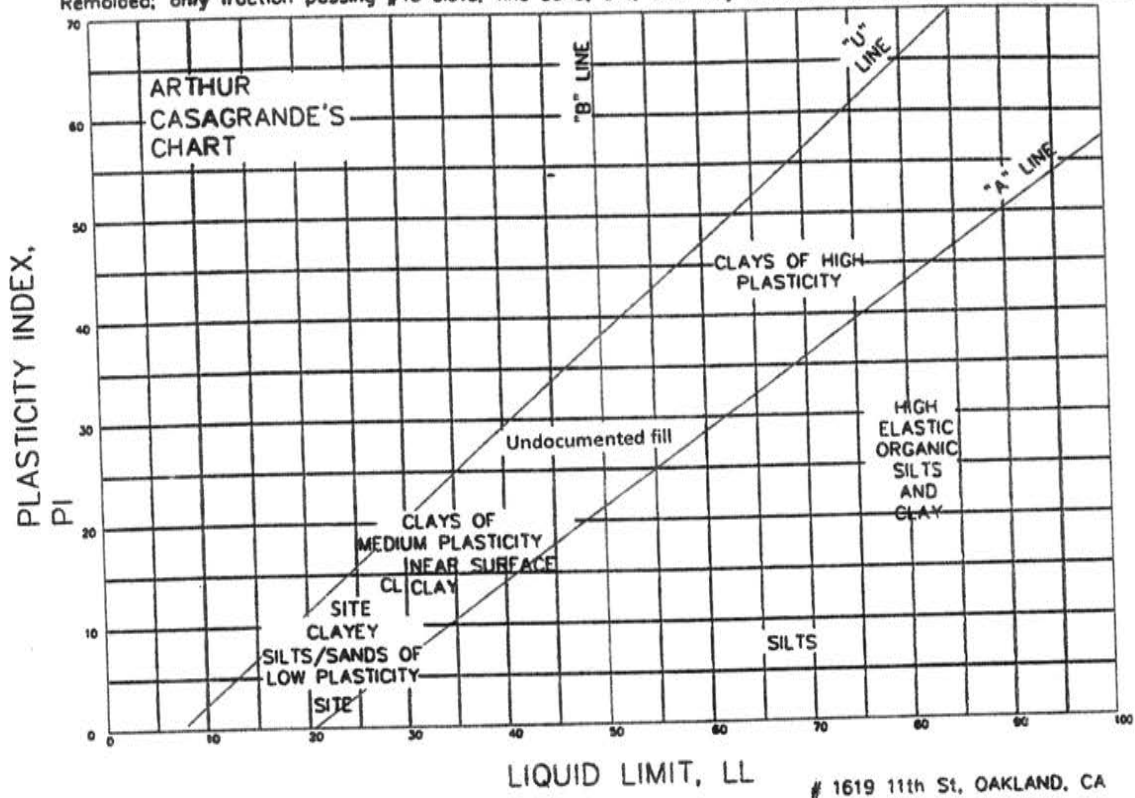

CBC 10 1803.5.3

Reference CBC10 1803.5.3 Item #1 and ASTM D4318

## CLASSIFICATION TEST RESULTS

SAMPLE IDENTIFICATION			ATTERBERG LIMITS			GRAIN SIZES % DRY WT.				
SAMPLE NO. (Boring/Pit/Bulk)	LETTER DESIGNATION	DESCRIPTION	LIQUID LIMIT	PLASTICITY INDEX	SHRINKAGE LIMIT	ESTIMATED % PASSING #40 SIEVE	SAND	SILT	CLAY	COLLOIDAL
	SITE	SURFACE/NEAR SURFACE SILTY BROWN A. SAND SM		—	—	—	—	—	—	—
	FILL									

Project 7970 GP

Hallenbeck / ALLWEST INC.

FIGURE 9

# SCHEMATIC DESIGN RECOMMENDATIONS PIER-SUPPORTED STRUCTURAL RETAINING WALL (RW)

TABLE 1610.1 AT REST (EXPANSIVE SOILS) .. OR ACTIVE (NOT FOR EXPANSIVE SOILS) Retaining Structures Sec 1807  
LATERAL EARTH PRESSURE FOUNDATIONS AND RETAINING WALLS STABILITY SLIDING, OVERTURNING, BUOYANCY

-TRIANGULAR PRESSURE DIAGRAM-

NORMAL CASE: Level backfill Bldg. wall non-yielding At Rest CBC Site wall slight-yielding allowed	80 PCF  ___ pcf
NORMAL CASE: Upslope H:V = 2:1 Bldg. wall non-yielding At Rest CBC P.S. interpolation for intermediate slopes is valid Site non-deflection <b>ADDITIONAL:</b> Surcharge upslope (adjoining bldg., traffic, etc)	___ pcf  ___ pcf  100 PSF Rectangular
Earthquake M-D (As applicable per <b>Seismic Loads CBC 13 Sec 1803.5.12.</b> Consult CBC 13 Risk Table 1604.5 Compaction pressures - heavy equipment	20 PCF inverted triangular  N/A pcf rectangular

Special Inspections CBC 13: Structural Concrete Sec 1705.3  
 Piers Sec 1705.8  
 Geotechnical Sec 1705.6 Piles Sec 1705.7

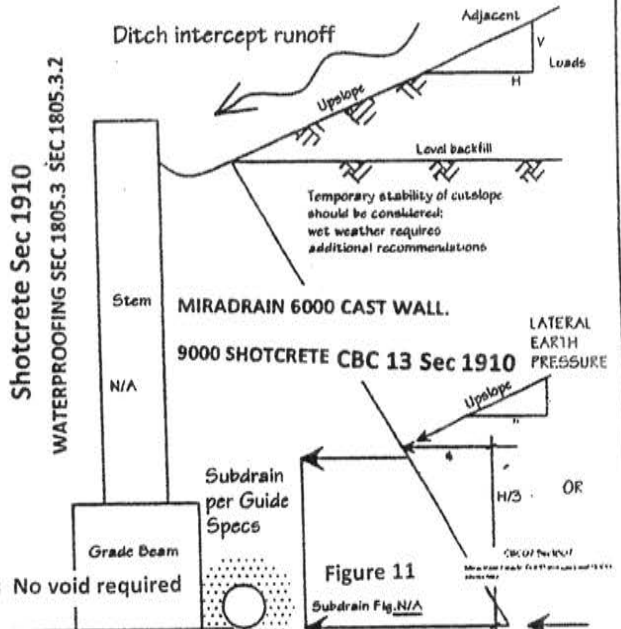

RW Seismic Loads CBC 13 Sec 1803.12

**CBC 13** SEC 1605.1.1 SEC 1807.2.3  
 SEC 1810.2.2 STABILITY Sec 1810.2.3 SETTLEMENT

SEC 1810.2.4 LATERAL LOADS / DEFLECTIONS NON LINEAR P-Y CURVES

**CBC 13 Sec 1808.7 Foundations on/@ slopes**

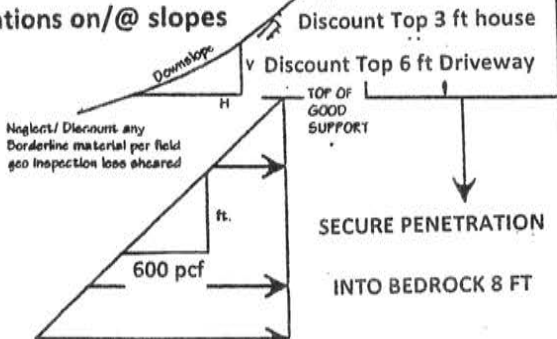

**CBC 13 1803.5.5 Lateral Load Capacity Group Action / OC spacings**

Min Total piers Lengths : House 11 FT ; Driveway 14 FT

Embedment in good supporting material based on flagpole equivalent formula; see geotechnical report for minimum requirements; final design by structural engineer; engineering inspections required. GE and/or CEG geology shaft inspection, typ required. CBC 13 Tables 1704A.8 and 9 Total \_\_\_ ft plan pier depths. SEC 1808.2.5

Allowable lateral bearing  $S_{10}$  or  $S_{50}$  pcf, based on pressure diagram and load shape factor = 2 (1.5 pier diameter) Much of those not needed where Lpile is used

ALLOWABLE SHAFT FRICTION CBC 13 SEC 1810.3.3.1.4 UPLIFT SEC 1810.3.3.1.5

GROUPS UPLIFT SEC 1810.3.3.1.6 TIP BEARING CBC 13 SEC 1810.3.3.1.7

CONCRETE MIN 3000 PSI CBC 13 TABLE 1808.8.1

# GUIDE SPECIFICATIONS FOR SUBDRAINS BEHIND RETAINING WALLS

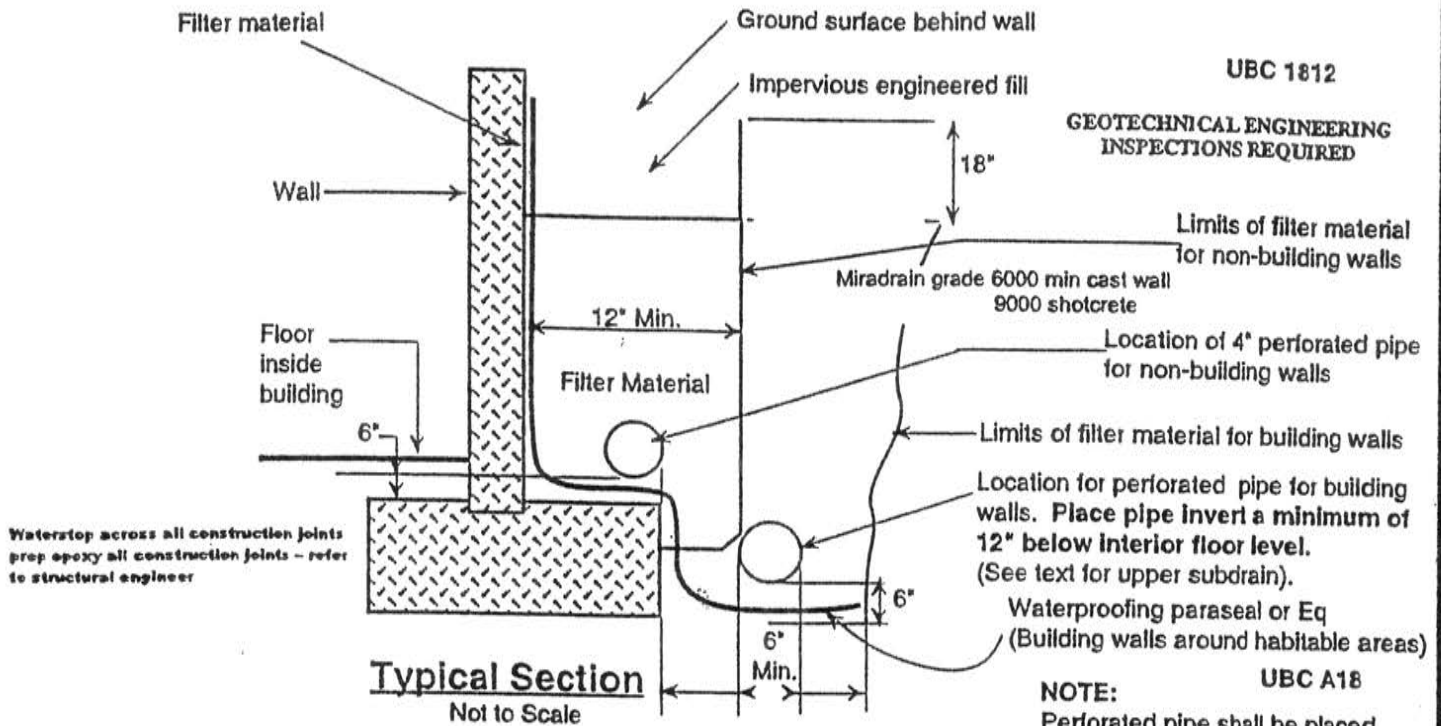

Subdrain outlets to have erosion control; T-pipe End

Subdrain pipe shall be manufactured in accordance with the following requirements:

- Acrylonitrile-butadiene-styrene (ABS) plastic pipe shall conform to the specifications for ABS plastic pipe given in ASTM Designation D2282 and ASTM Designation D2751. ABS pipe shall have a minimum pipe stiffness of 45 psi at 5% deflection when measured in accordance with ASTM Method D2412.
- Perforated clay pipe shall conform to the specifications for extra-strength perforated clay pipe of AASHTO Designation M-65.
- Polyvinylchloride (PVC) pipe shall conform to AASHTO Designation M278. PVC pipe shall have a minimum pipe stiffness of 50 PSI at 5% deflection and impact strength of at least 50-foot (bf) when measured in accordance with ASTM Method D2412. Pipes conforming to ASTM Designations D3034, F758, F810 (backfill less than 10-feet); Schedule 40 PVC, or equivalent shall be suitable. Also, corrugated HDPE pipes (smooth interior) that meet the stiffness and impact criteria.

## Filter Material

Filter material for use in backfilling trenches around and over subdrains and behind retaining walls shall consist of clean coarse sand and gravel or crushed stone conforming to the following requirements:

Sieve Size	% Passing Sieve
2"	100
3/4"	70 to 100
3/8"	40 to 100
#4	25 to 50
#8	15 to 45
#30	5 to 25
#50	0 to 20
#200	0 to 3

**CRITICAL:** Place subdrain pipe onto dish layout horizontal piece (not flat) of drain blanket (miradrain, etc.) to force collected water from blanket into subdrain pipe. Pipe must have uniform slope (no on/off situations) to outlet.

- Class 2 "Permeable Material" conforming to the State of California Department of Transportation Standard Specifications, latest edition, Section 68-1.025 shall be suitable.
- Clean, coarse gravel ("drainrock") shall be suitable, provided the subsurface drain is wrapped in an acceptable geotextile ("filter fabric").
- Miradrain 6200 drain blanket or approved equivalent is suitable in lieu of aggregate filter.
- Moistureproofing for building walls in habitable areas should be considered by the architect.

# PERIMETER CURTAIN SUBDRAIN AROUND BUILDING FOUNDATION

CBC 13 SEC 1805.4

CBC 13 Section 1805.4.2

Install Perimeter Subdrain To Avert water runoff intrusion into crawl space..

## GEOTECHNICAL ENGINEERING INSPECTIONS REQUIRED

**BUILDING**

### Backfill

Compact 90% RC ASTM D2922 / D1557 in improvements area — compact tight in landscape area.

### Construction

Install in segments not to undermine foundation / improvements.  
Shoring on contingency.

All roof spouts to be hooked up to nonper collector pipe.

P. S.: All new flatwork to drain away from building; wide flatwork to have area drains.

Refer to plan

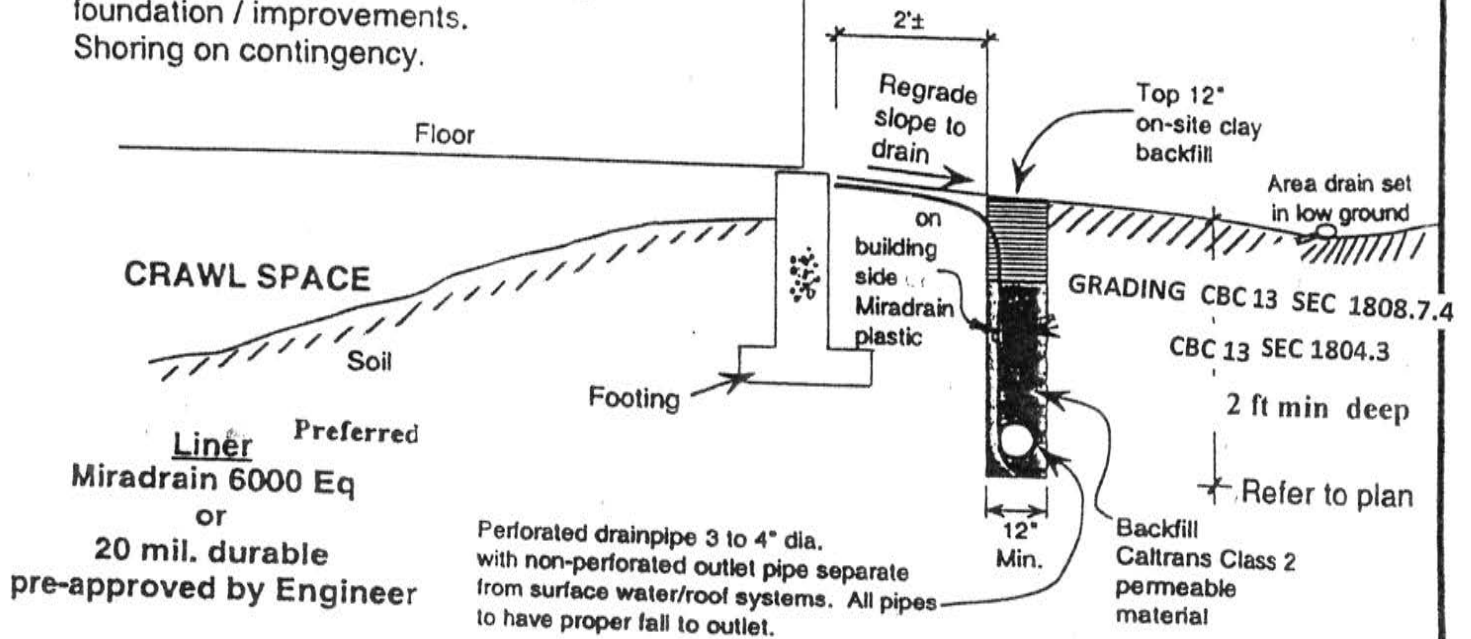

**CRAWL SPACE**

Liner Preferred  
Miradrain 6000 Eq  
or  
20 mil. durable  
pre-approved by Engineer

Perforated drainpipe 3 to 4" dia.  
with non-perforated outlet pipe separate  
from surface water/roof systems. All pipes  
to have proper fall to outlet.

Backfill  
Caltrans Class 2  
permeable  
material

### DRAINPIPE

All pipe systems to have cleanouts.

Perforated subdrain pipe shall be manufactured in accordance with one of the following requirements:

1. PVC conforming to AASHTO design M278 or ASTM D3034 (SDR 35), F758, F810 (backfill less than 10 feet) or approved equivalent alternate.
2. ABS conforming to ASTM designations D2282 and D2751.

Rev 1b

## GROUND MOTION APPENDIX...

SITE : New Home @ # 2367 Rainbow Court ,Hayward , CA

Lat : 37.6606      Long : -122.0506

CBC 13 SECTION 1613.3 SPECTRAL PARAMETERS ARE FOR

5 % LAMBDA DAMPING

2% 50 YEARS CONDITIONAL PROBABILITY

2500 years Return Period.....

**SITE CLASS B SELECTION** : The profile involves shallow depth to firm Kp Cretaceous bedrock , Upper 2 ft to 4 ft feet are Medium stiff Silty Clay CL . Bedrock is within 3 ft to 4 ft from existing grade.

Per CBC 13 Section 1613.3 :

This site can qualify as Class B ; No shear wave S velocity performed.

ATTACHED IS CBC 13 SPECTRAL PLOT FROM REGIONAL SPECTRAL CHARTS ....

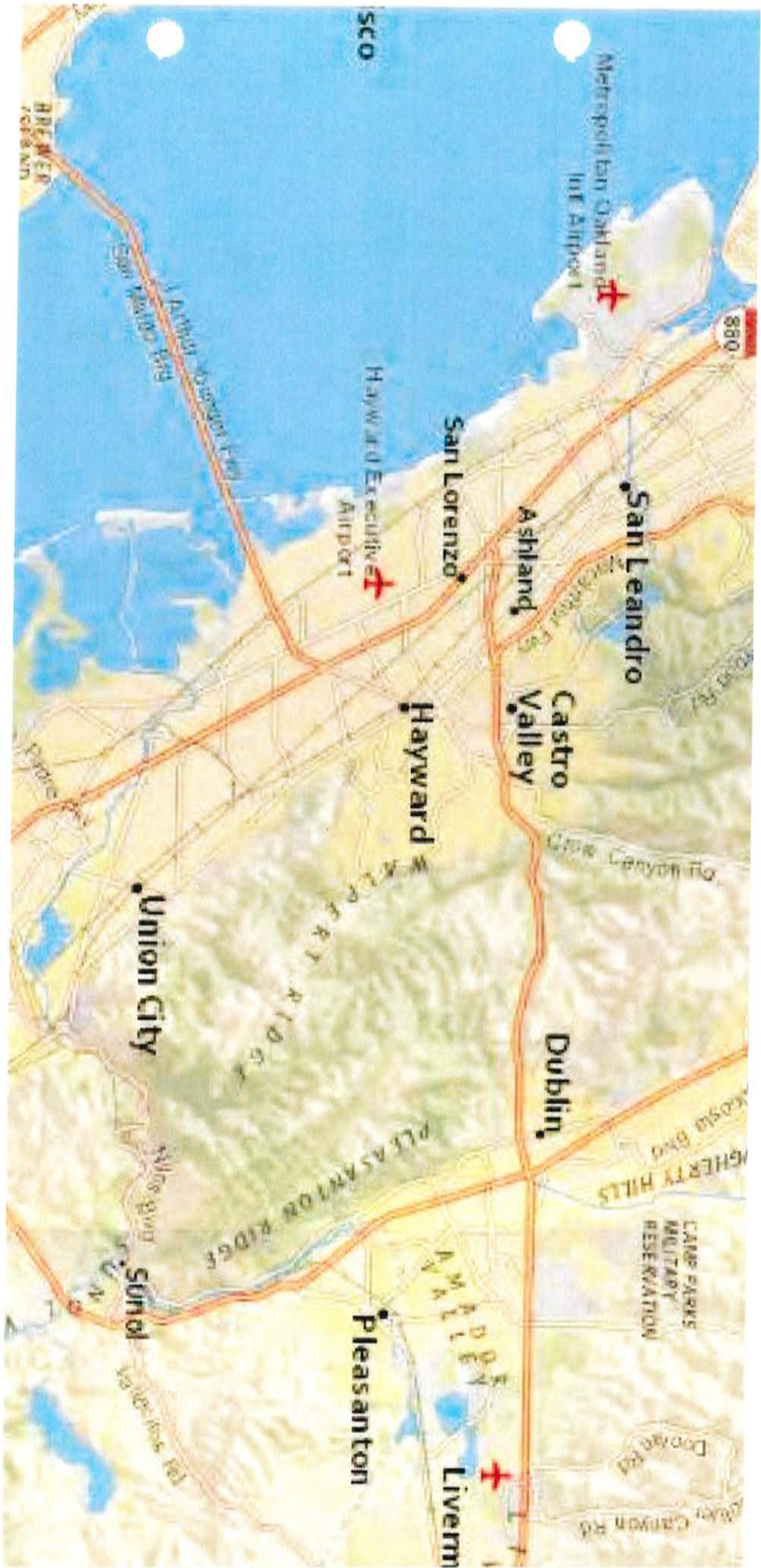

## APPENDIX A

### STRUCTURAL RC PIERS – RETAINING WALLS –INSTALLATION SPECIFICATIONS AND PROCEDURES

1. The contractor shall verify all conditions in the field, and mark work locations. Discrepancies, if any, between the conditions and design drawings shall be report to the engineer for clarification and adjustments before proceeding into the work. Permit plans shall apply. Contractor to secure and comply with all permits, grading, building, and drainage as applicable.  
  
Contractor is to review the text and logs of project geotechnical report for particular, pertinent conditions: rubble, fill, floater rocks, gravel beds, groundwater, etc.
2. **Foundation excavations (pier shafts, footings, etc.)** shall be inspected by the geotechnical engineer at the time of drilling – **AS IT HAPPENS** – to confirm final depth, etc.  
Special Inspections Per **CBC 13 SEC 1705.8.**
3. Groundwater is Not anticipated in Good weather.. But into Regulatory wet weather past mid October ,groundwater should be anticipated on / off . Pier excavations must be dewatered prior to placement of concrete. No more than 6 inches of water is allowed in the bottom of the excavation-tremie concrete placement. CBC 13 SEC 1803.4.
4. Construct piers first, then install the retaining wall; refer to plans and geotechnical **report to ascertain whether piers are to be installed in groups. Skip drill** and/or pier shafts to be backfilled with structural concrete on a fast track – same day, one or two days – may also be dictated by construction condition(s).
5. The contractor shall be responsible for any special inspection that may be required, per the most recent edition of the CBC 13 , CAC, City of Hayward OMC municipal code and/or formal permit; references CBC13 Sec 1705.3 ; ACI 318 -77 Section 5.6.2
6. Concrete should not mushroom out beyond the pier.
7. Refer to CBC 13 Sec 1910 for shotcrete concrete.
8. Wet weather drilling would require additional recommendations.
9. Contractor is responsible to locate, avoid conflicts with, and relocate if necessary, all existing utilities in the construction area. The services of USA may be obtained to locate utilities; and/or private utility locators –



USA locations may not be complete and therefore, in some cases, it may be necessary to expose utilities to confirm locations prior to drilling.

10. Pier and footings excavations are to be drilled plumb, clear from all fall-in, and maintained clean until concrete is poured; concrete should be cast against clean undisturbed excavation; no drilling spoils or tailings from the ground-up (pulverized) bedrock shall be allowed on the shaft of the piers.
11. Sonotubing to be used for pier shafts above grade and/or on steep grade in order to construct pier structural section to adjoin foundation/GB as required by design; where called for, all transfer rebar-cross lap rebar is to be inserted through/into Sonotubing as necessary to meet design requirements.
12. Pier drilling spoils may be used for engineer backfill; spoils may not be disposed on slopes.
13. All concrete construction joints to be prepped clean with MV epoxy as directed by the structural engineer.
14. Consult engineer on corrosion-sulfates; refer to CBC 13 CHP 19.

**GUIDE SPECIFICATIONS FOR SUB- SURFACE DRAINAGE  
GENERAL SITE DRAINAGE**

**REFERENCES : CBC 13 Sections 1804.3 ; 1805.2 , 1805.3 & 1805.4.2 , 1808.7.4**

**A. DESCRIPTION**

Subsurface drains consist of pipes and permeable filter materials installed beneath the ground surface and which collect and convey subsurface drainage water as called for by the plans , or the geotechnical engineer in the field. These specifications apply to construction dewatering as well as any permanent dewatering as called for by the plans. These specifications apply to both blanket and trench sub- drains.

Unless otherwise directed by the geotechnical engineer in the field , or shown on plans , the conduit shall be placed in a trench, and the trench shall be backfilled with pervious filter material. The conduit and pervious material shall meet the requirements for the materials given in these specifications. The materials for the sub-surface drains and the sizes of trenches shall be as shown on the plans , or as determined by the geotechnical engineer in the field

**B. MATERIALS**

1. **Sub-Drain Pipe** : Sub-drain pipes shall be manufactured in accordance with the following requirements:
  - a. Acrylonitrile-Butadiene-Styrene (ABS) plastic pipe shall conform to the specifications for ABS plastic pipes given in ASTM Designation D 2282 and ASTM Designation D 2751. ABS pipes shall have a minimum pipe stiffness of 45 psi at 5% deflection, when measured in accordance with ASTM Method D 2412.
  - b. Polyvinyl Chloride (PVC) pipe shall conform to AASHTO Designation M 278. PVC pipes shall have a minimum pipe stiffness of 50 psi at 5% deflection and impact strength of at least 50 psi (or kpa) when measured in accordance with ASTM Method D 2412. Pipes conforming to ASTM Designations D 3034 , F 758 , F 810 (for backfill less than 10 ft ) such as Schedule 40 , or equivalent shall be suitable.
2. **Pervious –Permeable Backfill Material** : Pervious materials for use in backfilling trenches and subdrainage galleries shall conform to the requirements of paragraph “C1” ( aggregate filter) of these specifications . Alternatively, pervious material conforming to the requirements of paragraph “C2” (drainrock) may be used , provided that the backfill is fully wrapped in a suitable geotextile “filter fabric” meeting the requirements given on section “D”. The choice of this option should be subject to the prior approval of the geotechnical engineer.

**C. BACKFILL MATERIAL**

1. **Aggregate Filter Material**: Filter material for use in backfilling trenches around and over sub-drain pipes and behind retaining walls shall consist of clean coarse sand and gravel or crushed stone conforming to the following requirements :

SIEVE SIZE	% PASSING SIEVE
2”	100
3/4 “	70-100
3/8 “	40-100
#4	25-50
#8	15-45
#30	5-25
#50	0-20
#200	0-3

Class 2 “ Permeable Material” conforming to Caltrans Standard Specifications , latest edition , Section 68-1.025 Shall be suitable. Caltrans Perm Class 1A may be acceptable when approved by the geotechnical engineer. Class 2 AB and ASB are NOT acceptable.

2. **Gravel (Drainrock)** : Gravel for use in pervious blankets and in backfilling trenches or wrapped in filter fabric , meeting the requirements of Section D of these specifications , shall consist of clean fresh stone conforming to the following grading requirements :

SIEVE SIZE	% PASSING SIEVE
1”	100
1/2”	50-100
#4	40-100
#8	0-40
#30	0-20

#50 0-5  
#200 0-3

Caltrans Class "Permeable Material" Standard Specifications Section 68-1.025 shall be suitable. Caltrans perm Class 1B may be suitable when approved by the geotechnical engineer.

**D. GEOTEXTILE-FILTER MATERIAL**

Geotextile for use in sub-drains or as directed by the geotechnical engineer shall be of non- woven , needle punch construction and consist of long chain polymeric fibers composed of polypropylene , polyethylene ,or polyamide. The filters shall be oriented to a multi-directional , stable network . The geotextile shall conform to the physical property requirements listed below:

PHYSICAL PROPERTY	TEST METHOD	ACCEPTABLE TYPICAL TEST RESULTS
Tensile Strength, wet, lbs	ASTM D 1682	90 (minimum)
Elongation , wet , %	ASTM D 1682	40 (minimum)
Coefficient of Water Permeability cm/sec	ASTM D 4491	0.1 (minimum)
Pore size –EOS US Standard Sieve	ASTM D 4751	40 (maximum)

A Mirafi 140 N or equivalent shall be suitable.

The geotextile shall be furnished in a protective wrapping which shall protect the fabric from ultraviolet radiation and from abrasion due to shipping and handling.

**E. LAYING AND PLACING**

The drainpipe and filter material shall be placed as shown on the plans and as determined by the geotechnical engineer in the field. Unless otherwise directed by the geotechnical engineer , perforated pipe shall be laid with the perforations side facing down.

**Trench Backfill**

After excavating the sub-surface drain trench, but before placing the perforated sub-drain pipe , a minimum of 6" of aggregate filter material shall be placed on the trench bottom. The filter material shall be rounded to conform to the curvature of the pipe so that the pipe is carefully bedded. The trench shall then be backfilled , with the same filter material above the pipe , and the backfill is tamped or hand wedged into place to provide firm supports at the sides of the pipe. As a minimum , pipes of subdrain blankets or trench subdrains , shall be surrounded by permeable aggregate material at the rate of 10 cubic feet per foot of pipes , unless specifically called for on the plans and approved by the geotechnical engineer. In general, the installation shall follow the guidelines of ASTM Designation D 2774 , except that compaction of the filter material in the trench shall not be required. The perforated sub-drain pipe shall be wrapped in a fabric sleeve "sock" as an additional protection , in addition to the aggregate material surround.

Sub-surface drains shall be placed to the depths, lines and grades shown on the plans and as directed by the geotechnical engineer in the field. Sub-surface drains should be connected by an outlet "tightline" collector and led to discharge in a suitable outlet as defined in the field by the geotechnical engineer , or as shown on the permit plans. An impervious "Plug" should be placed at the connection between the perforated pipe and the outlet "tightline" collector .

Backfill around the non perforated outlet "tightline" collector pipe shall be a compacted onsite , non-pervious clay material ; No crushed rock may be used to backfill outlet non-perforated collector pipes.

The sub-drain "tightline" collector system shall be separate from and shall not convey water from surface drainage improvements and any roof downspouts, unless otherwise specifically approved by the engineer. Both the sub-drain and the outlet "tightline" collector shall have adequate hydraulic fall to the outlet release location; a minimum fall of 2% shall be provided ( one foot drop in 50 lineal feet of pipe ) , unless otherwise approved by the engineer.

For deep fills and landslide repairs , multiple depth sub-drains and/or chimney extensions would be required. The contractor is to review such situations with the geotechnical engineer..Additional sub-drains shall be provided in areas where significant groundwater seepage and/or springs are encountered or exposed during grading and excavations required to secure the grade into competent materials. Separate non-perforated outlet pipes would be required in areas of intense seepages.

The contractor shall, at his own expense, replace all drainage pipes that are damaged during the installation process or, Sub-Surface Drains not placed at the lines and grades called for on the permit plans, or as determined by the geotechnical engineer in the field.

The geotextile shall be placed in the manner and at the locations shown on the plans. The surface to receive the fabric and/or the trench into which the fabric is to be placed shall be prepared to a smooth condition free of wrinkles, obstructions and debris.

The geotextile shall be covered with a permeable material within two weeks from its placement. Should the fabric be damaged during construction, the torn or punctured section shall be repaired by placing a piece of fabric that is large enough to cover the damaged area and to meet the overlap requirement. Adjacent borders of the geotextile shall be overlapped a minimum of 12" or sewn. The preceding roll shall be the following roll in the direction the material is being placed. The geotextile blanket seams should be secured and attached, per manufacturer's specifications/ procedure.

**IMPORTANT :** Pipe hookups shall be such that no backflow can occur from the collector pipes into perforated sub-drain pipes / sub-drains or other improvements. No backflow from downspout collectors shall occur into site area drains. The contractor is to set collector pipes at proper elevations, provide sanitary sweep elbows and/or non-return valves, as appropriate to prevent such backflows. All backfill of collector non-perforated pipes is to be moderately compacted using onsite non-pervious clay material; NO crushed rock may be used. A "plug" of non-pervious backfill around perforated subdrain pipes must be placed at the location of the start of non-perforated collector pipe sections.

#### F. CLEANOUTS

At the direction of the geotechnical engineer, cleanouts shall be provided and the ends of pipes and at junctions and connections of pipes. Junction angles should be no steeper than 45 degrees where cleanout pipes connect to the subdrain pipes. Cleanout should be provided with caps. In many cases horizontal cleanouts may pose less construction problems than vertical cleanouts.

#### G. GENERAL SITE DRAINAGE CBC13 Section 1804.3 & 1808.7.4

The following should be observed on plans and approved by Geotechnical / Civil Engineers for the project :

Site area drains are to be set at low- finish graded areas; conformed to grades. No outlet collector pipes are to discharge openly on slopes; pipes are to release/outlet in approved disposal locations. Measures shall be undertaken to prevent erosion at approved disposal areas, as required. Such measures may include riprap, cobbles, gravel, and engineered energy dissipaters; placement of fabric and / or aggregate filters; fiber rolls and or hay bales. The outlet collector non-perforated pipes are to be secured in the ground. Roof downspouts are to be directly hooked up to collector non-perforated pipes. All pipes are to have proper slope (fall) to outlets. Riser clean outs are to be provided with caps.

Outlet disposals into creeks – water courses require fitting the outlet pipes with non-return check valves to prevent backflow into the drainage systems.

**IMPORTANT:** Pipe hook ups shall be such that no backflow can occur from collector pipes into perforated Sub-drains or other drainage improvements; no backflow or diversion from downspout collector pipes into site area drains. Contractor is to set collector pipes at proper elevations and provide appropriate safeguards to avert backflows. Safeguards such as: sanitary sweeps, offset pipes, non-return check valves, etc. All backfills of collector non-perforated pipes is to be moderately compacted using onsite non-pervious materials. NO crushed or drainrock backfill may be used, unless a PLUG is placed as per geotechnical engineer guidance. In this case a PLUG of non-pervious material shall be placed tight at the transition from perforated sub-drain pipes to solid non-perforated collector outlet pipes.