



**SHEET INDEX**

COVER SHEET - SHEET INDEX

CIVIL PLANS

- TM.1 VESTING TENTATIVE MAP - EXISTING PROPERTY
- TM.2 VESTING TENTATIVE MAP - SITE PLAN
- TM.3 VESTING TENTATIVE MAP - GRADING PLAN
- TM.4 VESTING TENTATIVE MAP - UTILITY PLAN
- TM.5 VESTING TENTATIVE MAP - APARTMENT GRADING AND UTILITY PLAN
- TM.6 VESTING TENTATIVE MAP - STORMWATER CONTROL PLAN
- C.1 OPEN SPACE EXHIBIT
- C.2 SITE CONTEXT EXHIBIT

LANDSCAPE PLANS - CONDOMINIUMS

- L0.1-C COVER SHEET
- L0.2-C NOTES AND LEGEND
- L0.3-C HYDROZONE PLAN
- L1.1-C EXISTING TREE SURVEY
- L2.1 -C LANDSCAPE CONCEPT
- L2.2-C LANDSCAPE CONCEPT ENLARGEMENT
- L3.1-C LANDSCAPE DETAILS
- L3.2-C LANDSCAPE DETAILS
- L3.3-C LANDSCAPE DETAILS
- L3.4-C LANDSCAPE DETAILS
- L4.1-C IRRIGATION PLAN
- L4.2-C IRRIGATION NOTES & LEGEND
- L4.3-C IRRIGATION DETAILS
- L4.4-C IRRIGATION DETAILS
- L4.5-C IRRIGATION DETAILS
- L4.6-C IRRIGATION DETAILS
- L4.7-C IRRIGATION DETAILS & CALCS

ARCHITECTURAL PLANS - CONDOMINIUMS

- A1-C 5 UNIT BUILDING FIRST FLOOR PLAN
- A2-C 5 UNIT BUILDING SECOND FLOOR PLAN
- A3-C 5 UNIT BUILDING THIRD FLOOR PLAN
- A4-C 5 UNIT BUILDING ROOF PLAN
- A5-C 5 UNIT BUILDING FRONT & RIGHT ELEVATION
- A6-C 5 UNIT BUILDING REAR & LEFT ELEVATION
- A7-C COLOR SCHEME SHEET

LANDSCAPE PLANS - APARTMENTS

- L0.1-A COVER SHEET
- L0.2-A NOTES & LEGEND
- L0.3-A PLANTING NOTES
- L0.4-A HYDROZONE PLAN
- L1.1 -A LAYOUT PLAN
- L2.1-A PLANTING PLAN
- L3.1-A IRRIGATION PLAN
- L3.2-A IRRIGATION DETAILS
- L3.3-A IRRIGATION DETAILS
- L3.4-A IRRIGATION DETAILS
- L3.5-A IRRIGATION DETAILS
- L3.6-A IRRIGATION DETAILS
- L3.7-A IRRIGATION DETAILS
- L5.1-A CONSTRUCTION DETAILS
- L5.2-A CONSTRUCTION DETAILS

ARCHITECTURAL PLANS - APARTMENTS

- A.1-A ARCHITECTURAL SITE PLAN & SECTION
- A.2-A ELEVATIONS
- A.3-A ELEVATIONS
- A.4-A FIRST FLOOR PLAN
- A.5-A SECOND FLOOR PLAN
- A.6-A THIRD FLOOR PLAN
- A.7-A FORTH FLOOR PLAN
- A.8-A ROOF PLAN
- A.9-A UNIT PLANS
- A.10-A BUILDING SECTION & DETAILS
- A.11-A COMMON OPEN SPACE EXHIBIT
- A.12-A EXTERIOR MATERIALS & COLORS

DEVELOPER - CONDOMINIUMS

KB HOME  
5000 EXECUTIVE PARKWAY  
SAN RAMON, CA 94583  
(925) 938-4527  
CONTACT: RAY PANEK

DEVELOPER - APARTMENTS

DNS CAPITAL PARTNERS, LLC  
1350 TREAT BLVD, SUITE 400  
WALNUT CREEK, CA 94583  
(925) 890-3232  
CONTACT: ROBERT TELLES

CIVIL ENGINEER

CARLSON, BARBEE & GIBSON INC.  
2633 CAMINO RAMON  
SAN RAMON, CA 94582  
(925) 866-0322  
CONTACT: LEE ROSENBLATT

LANDSCAPE ARCHITECT

GATES + ASSOCIATES  
2671 CROW CANYON PLACE  
SAN RAMON, CA 94583  
(925) 736-8176  
CONTACT: MELONIE O'SULLIVAN

ARCHITECT - CONDOMINIUMS

SDG ARCHITECTS, INC.  
3361 WALNUT BLVD, SUITE 120  
BRENTWOOD, CA 84513  
(925) 634-7000  
CONTACT: JENNIFER MASTRO

ARCHITECT - APARTMENTS

SDG ARCHITECTS, INC.  
3361 WALNUT BLVD, SUITE 120  
BRENTWOOD, CA 84513  
(925) 634-7000  
CONTACT: SCOTT PRICKETT

AUGUST 2017



# TELLES PROPERTY - TRACT 8335

## SITE PLAN REVIEW

HAYWARD, CALIFORNIA

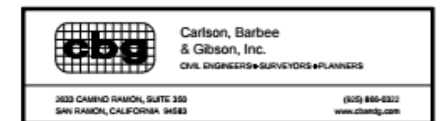

### LEGEND

EXISTING	PROPOSED	DESCRIPTION
---	---	SUBDIVISION BOUNDARY
---	---	RIGHT-OF-WAY
---	---	EASEMENT
---	---	SIDEWALK
---	---	FENCE
○	○	SPOT ELEVATIONS
○	○	APPROXIMATE TREE LOCATION

### ABBREVIATIONS

DW	DRIVEWAY
EX	EXISTING
FC	FACE OF CURB
PL	PROPERTY LINE
PUE	PUBLIC UTILITY EASEMENT
RW	RIGHT-OF-WAY
SW	SIDEWALK
TYP	TYPICAL

### CONTACTS:

- DEVELOPER:** KB HOMES  
5000 EXECUTIVE PARKWAY, SUITE 125  
SAN RAMON, CALIFORNIA 94583  
(925) 983-4527  
JOHN COMPAGLIA
- OWNER:** DNS CAPITAL PARTNERS, LLC  
1350 TREAT BLVD, SUITE 400  
WALNUT CREEK, CA 94597  
(925) 890-3232  
ROBERT TELLES
- ENGINEER:** CARLSON, BARBEE & GIBSON, INC.  
2633 CAMINO RAMON, SUITE 350  
SAN RAMON, CALIFORNIA 94583  
(925) 866-0322  
LEE ROSENBLATT, RCE 65469
- SOILS ENGINEER:** STEVENS, FERRONE & BAILEY  
1600 WILLOW PASS COURT  
CONCORD, CA 94520  
(925) 688-1001  
KENNETH C. FERRONE

WE, DNS CAPITAL PARTNERS, LLC, AGREE TO THE FILING OF SAID MAP AND TO COMPLY WITH THE PROVISIONS OF THE CITY OF HAYWARD SUBDIVISION ORDINANCE AND THE STATE MAP ACT AS THEY APPLY TO THE PROCESSING AND APPROVAL OF SAID MAP.

BY: \_\_\_\_\_ DATE: \_\_\_\_\_

I, LEE ROSENBLATT, CERTIFY THAT THIS TENTATIVE MAP WAS PREPARED BY ME OR UNDER MY DIRECT SUPERVISION AND THAT IT COMPLIES WITH THE CITY OF HAYWARD SUBDIVISION ORDINANCE AND THE STATE MAP ACT.

BY: LEE ROSENBLATT, RCE #65469 DATE: \_\_\_\_\_

I, MARK H. WEBER, A LICENSED LAND SURVEYOR IN THE STATE OF CALIFORNIA, HEREBY STATE THAT THIS TENTATIVE MAP IS BASED UPON A SURVEY UNDER MY DIRECT SUPERVISION AND THAT IT COMPLIES WITH THE CITY OF HAYWARD SUBDIVISION ORDINANCE AND THE STATE MAP ACT.

BY: MARK H. WEBER DATE: \_\_\_\_\_

A SOILS REPORT ON THIS PROPERTY HAS BEEN PREPARED BY STEVENS, FERRONE AND BAILEY, ENTITLED "GEO TECHNICAL INVESTIGATION TELLES PROPERTY RESIDENTIAL DEVELOPMENT", DATED 02/16, WHICH HAS BEEN FILED WITH THE CITY OF HAYWARD.

BY: KENNETH C. FERRONE DATE: \_\_\_\_\_

### SHEET INDEX

SHEET NO.	SHEET TITLE
TM.1	EXISTING PROPERTY
TM.2	SITE PLAN
TM.3	GRADING PLAN
TM.4	UTILITY PLAN
TM.5	APARTMENT GRADING AND UTILITY PLAN
TM.6	STORMWATER CONTROL PLAN

VICINITY MAP  
NOT TO SCALE

### GENERAL NOTES:

- ACCESSORS PARCEL NO.: 452-0036-30-05
- SITE ADDRESS: 26601 MISSION BOULEVARD, HAYWARD, CA
- SITE AREA: 2.70± ACRES (GROSS)  
2.14 ACRES (NET-GROSS-DRIVE AISLES)  
27.4 DU/AC (GROSS)  
34.6 DU/AC (NET)
- EXISTING ZONING: MT-T4-2 URBAN GENERAL ZONE  
PROPOSED ZONING: MT-T4-2 URBAN GENERAL ZONE
- EXISTING USE: MIXED USE  
PROPOSED USE: LOTS 1-7 - MUTJ-FAMILY RESIDENTIAL - 7 BUILDINGS, 35 UNITS  
LOT 8 - 1 APARTMENT BUILDING - 39 UNITS & 1,020 SF COMMERCIAL  
PARCELS A-C - COMMON PARCELS FOR BENEFIT OF LOTS 1-7  
PARCELS D&E - COMMON PARCELS FOR BENEFIT OF LOTS 1-8
- BENCHMARK: TOP OF BRASS DISK ON BRIDGE DECK ON WHITMAN STREET OVERPASS OVER HARDER ROAD. ELEVATION = 68.64 NGVD29, CITY OF HAYWARD DATUM MONUMENTATION PLAT FILE NO. 1-42
- EXISTING STRUCTURES: ALL EXISTING BUILDINGS AND PAVEMENT WITHIN BOUNDARY TO BE REMOVED
- STREETS: ALL ROADWAYS WITHIN THE SUBDIVISION WILL BE PRIVATE AND WILL BE PRIVATELY MAINTAINED BY THE HOMEOWNER'S ASSOCIATION. ALL PRIVATE STREETS WILL BE WITHIN PUE'S. THE MINIMUM LONGITUDINAL SLOPE OF ALL STREETS IS TO BE 0.50%.
- TREES: TREES ALONG SOUTHWEST BOUNDARY TO REMAIN. ALL OTHER TREES WITHIN SITE BOUNDARY TO BE REMOVED AND OR RELOCATED.
- STREET TREES: STREET TREES SHALL BE INSTALLED PER SD-122
- WALLS AND FENCING: ALL WALLS AND FENCING WILL BE PRIVATE FACILITIES AND PRIVATELY MAINTAINED
- STORM DRAIN: PROPOSED ONSITE STORM DRAIN FACILITIES WILL BE PRIVATE FACILITIES AND WILL BE PRIVATELY MAINTAINED BY THE HOMEOWNER'S ASSOCIATION
- PUBLIC UTILITIES: PROPOSED ONSITE WATER AND SANITARY SEWER FACILITIES ARE PUBLIC AND WILL BE WITHIN A SANITARY AND/OR WATER EASEMENT. PROPOSED WATER AND SANITARY SEWER FACILITIES WILL BE CONSTRUCTED PER CITY OF HAYWARD STANDARDS AND DEDICATED TO THE CITY.
- FLOOD ZONE: ZONE-X AREAS DETERMINED TO BE OUTSIDE THE 0.2% ANNUAL CHANCE FLOODPLAIN  
REFER TO: FLOOD INSURANCE RATE MAP  
PANEL 06001C0289G, AUGUST 3, 2009
- WELLS ONSITE: NONE
- WATER: CITY OF HAYWARD
- SEWER: CITY OF HAYWARD
- GAS & ELECTRIC: PG&E
- TELEPHONE: SBC
- CABLE TV: COMCAST CABLE
- DIMENSIONS: ALL DIMENSIONS ARE PRELIMINARY AND SUBJECT TO FINAL MAP
- PARCEL MAP/FINAL MAP: A PARCEL MAP WILL BE FILED FOR THIS PROPERTY FOR PHASING AND PROPERTY TRANSFER PURPOSES. MULTIPLE FINAL MAPS MAY BE FILED FOR THIS SITE FOR PHASING PURPOSES.
- CONDOMINIUM MAP: A CONDOMINIUM MAP WILL BE RECORDED FOR ALL FOR SALE UNITS. THE SUBDIVISION IS A CONDOMINIUM PROJECT AS DEFINED IN SECTION 1350 ET. SEQ. OF THE CIVIL CODE OF THE STATE OF CALIFORNIA AND FILED PURSUANT TO THE SUBDIVISION MAP ACT.
- MAINTENANCE: A HOMEOWNERS ASSOCIATION WILL BE FORMED TO OWN AND MAINTAIN LOTS 1-7, PARCELS A-E, AND EASEMENTS A & B. THE APARTMENT SITE OWNER SHALL BE RESPONSIBLE TO MAINTAIN ALL PRIVATE AMENITIES ON LOT 8 WITH THE EXCEPTION OF EASEMENTS A & B.

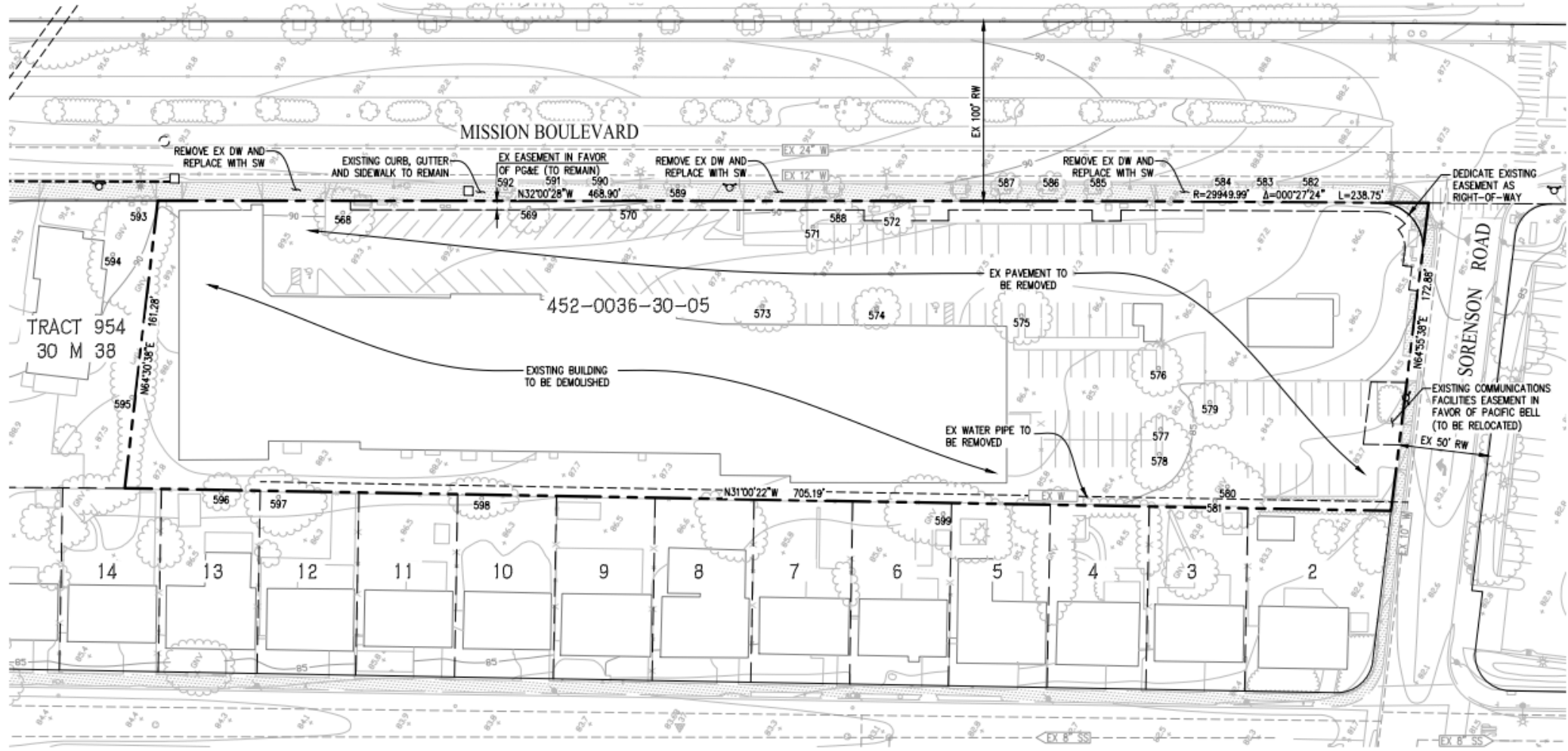

#### TREE SUMMARY

TREE NO.	SPECIES	DIAMETER (IN)	DISPOSITION
568	HACKBERRY	14	TO BE REMOVED
569	HACKBERRY	10	TO BE REMOVED
570	HACKBERRY	11	TO BE REMOVED
571	HACKBERRY	11	TO BE REMOVED
572	HACKBERRY	11	TO BE REMOVED
573	HACKBERRY	11	TO BE REMOVED
574	HACKBERRY	9	TO BE REMOVED
575	HACKBERRY	11	TO BE REMOVED
576	HACKBERRY	14	TO BE REMOVED
577	HACKBERRY	6	TO BE REMOVED
578	HACKBERRY	9	TO BE REMOVED
579	HACKBERRY	11	TO BE REMOVED

#### TREE SUMMARY

TREE NO.	SPECIES	DIAMETER (IN)	DISPOSITION
580	HACKBERRY	9	TO BE REMOVED
581	BLACKWOOD ACACIA	20	TO BE REMOVED
582	LONDON PLANE	5	PRESERVE
583	LONDON PLANE	4	PRESERVE
584	LONDON PLANE	5	PRESERVE
585	LONDON PLANE	5	PRESERVE
586	LONDON PLANE	4	PRESERVE
587	LONDON PLANE	4	PRESERVE
588	LONDON PLANE	4	PRESERVE
589	LONDON PLANE	4	PRESERVE
590	LONDON PLANE	5	PRESERVE
591	LONDON PLANE	4	PRESERVE

#### TREE SUMMARY

TREE NO.	SPECIES	DIAMETER (IN)	DISPOSITION
592	LONDON PLANE	4	PRESERVE
593	CALIF. BLACK WALNUT	24, 20 (44)	PRESERVE
594	CALIF. PEPPER	36	PRESERVE
595	HOLLY OAK	8	PRESERVE
596	PRIVET	4,3,3,2,2,1 (15)	PRESERVE
597	AVOCADO	9	PRESERVE
598	PEACH	4,3,3,2 (12)	PRESERVE
599	COAST LIVE OAK	30	PRESERVE

# VESTING TENTATIVE MAP FOR CONDOMINIUM PURPOSES

## EXISTING PROPERTY

# TELLES PROPERTY - TRACT 8335

CITY OF HAYWARD ALAMEDA COUNTY CALIFORNIA

SCALE: 1" = 40'

2633 CAMINO RAMON, SUITE 350  
SAN RAMON, CALIFORNIA 94583  
(925) 866-0322  
www.cbgi.com

SHEET NO.  
**TM.1**

DATE: MAY 2017  
JOB NO.: 2492-000

NOTE: PER ARBORIST REPORT PREPARED BY HORT SCIENCE DATED FEBRUARY 2016

**ABBREVIATIONS**

AU	ACCESSIBLE UNIT
VU	VISITABLE UNIT
BRC	BACK OF ROLLED CURB
BD	BOUNDARY
C	COMPACT
DW	DRIVEWAY
EVAE	EMERGENCY VEHICLE ACCESS EASEMENT
EX	EXISTING
FC	FACE OF CURB
H	HANDICAP SPACE
LS	LANDSCAPE
PL	PROPERTY LINE
PAE	PUBLIC ACCESS EASEMENT
PSDE	PRIVATE STORM DRAIN EASEMENT
PUE	PUBLIC UTILITY EASEMENT
RW	RIGHT-OF-WAY
SSE	SANITARY SEWER EASEMENT
SW	SIDEWALK
TYP	TYPICAL
WLE	WATER LINE EASEMENT

**LEGEND**

EXISTING	PROPOSED	DESCRIPTION
- - - - -	- - - - -	SUBDIVISION BOUNDARY
- - - - -	- - - - -	PERIMETER MASONRY WALL
- - - - -	- - - - -	FENCE ON TOP OF RET WALL
- - - - -	- - - - -	FENCE
- - - - -	- - - - -	LOT LINE/RIGHT OF WAY
- - - - -	- - - - -	RIGHT OF WAY
- - - - -	- - - - -	EASEMENT
- - - - -	- - - - -	SIDEWALK
- - - - -	- - - - -	BIORETENTION AREA
- - - - -	- - - - -	DECORATIVE PAVING
- - - - -	- - - - -	CURB CUT

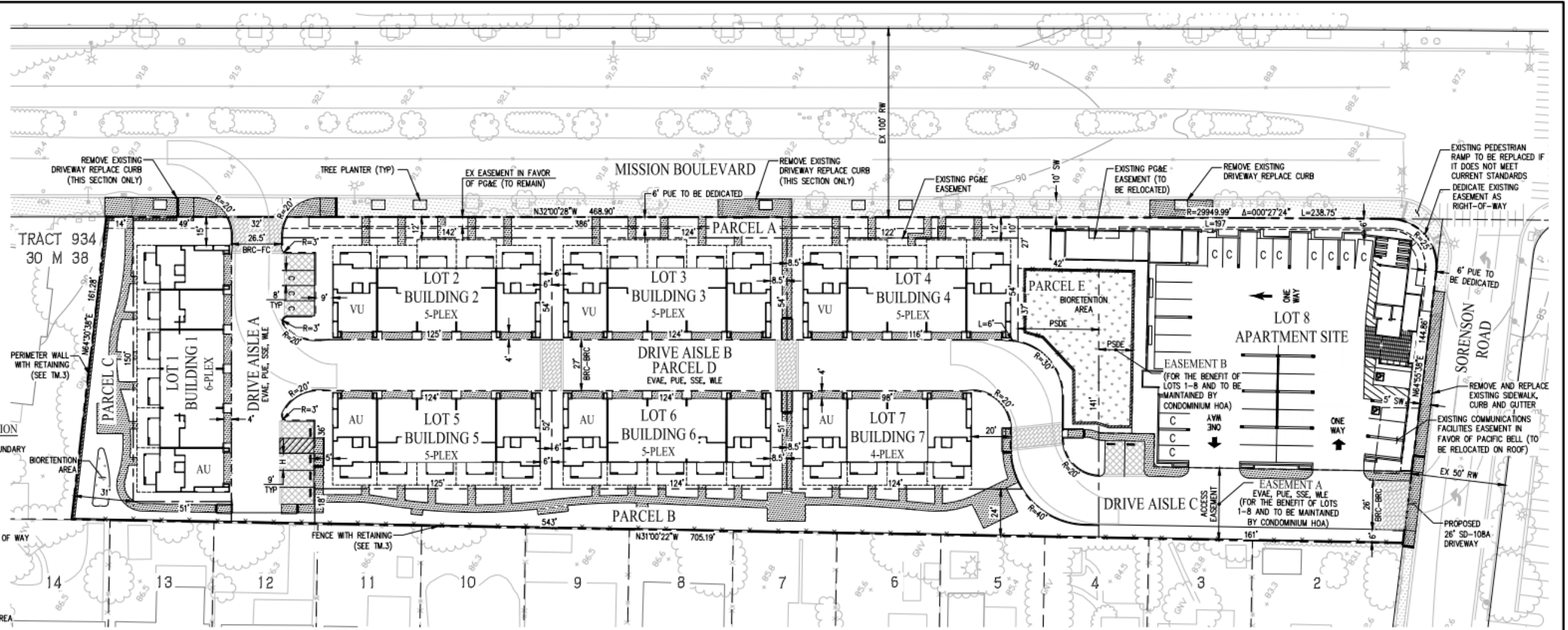

**DEVELOPMENT SUMMARY**

BUILDING TYPE	BUILDING TOTAL	BUILDING MIX (% TOTAL)	UNIT TOTAL
4-PLEX	1	14%	4
5-PLEX	5	72%	25
6-PLEX	1	14%	6
SUBTOTAL	7	100%	35
APARTMENT	39	-	39
<b>TOTAL</b>			<b>74</b>

**PARKING SUMMARY (CONDOMINIUMS)**

PARKING TYPE	PARKING REQUIRED		PARKING PROVIDED	
	RATIO	NUMBER OF SPACES	RATIO	NUMBER OF SPACES
GARAGE	2 SPACES/DU	70 SPACES	2 SPACES/DU	70 SPACES
ON-STREET/GUEST	0.10 SPACE/DU	4 SPACES	0.23 SPACE/DU	8 SPACES
<b>TOTAL</b>	<b>2.1 SPACES/DU</b>	<b>74 SPACES</b>	<b>2.23 SPACES/DU</b>	<b>78 SPACES</b>

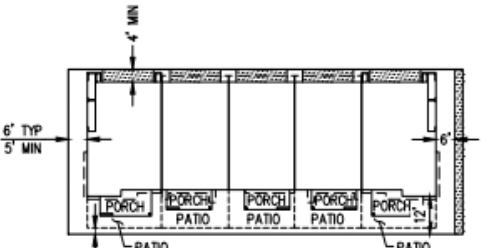

**SITE DENSITY (GROSS AREA 2.70 AC)**

BUILDING TYPE	BUILDING UNITS (DU)	NET AREA (AC)
CONDOMINIUM	35	1.55
APARTMENT	39	0.59
<b>TOTAL</b>	<b>74</b>	<b>2.14</b>
<b>SITE DENSITY</b>		<b>34.6 DU/AC</b>

- NOTES:**
- ON-STREET/GUEST PARKING DOES NOT INCLUDE LEGAL PUBLIC PARKING.
  - ONE VAN ACCESSIBLE SPACE IS PROVIDED (DENOTED BY "H" ON PLANS).
  - DOES NOT INCLUDE TWO SPACES ON APARTMENT SITE. SEE ARCHITECTURE SITE PLAN FOR APARTMENT PARKING SUMMARY.

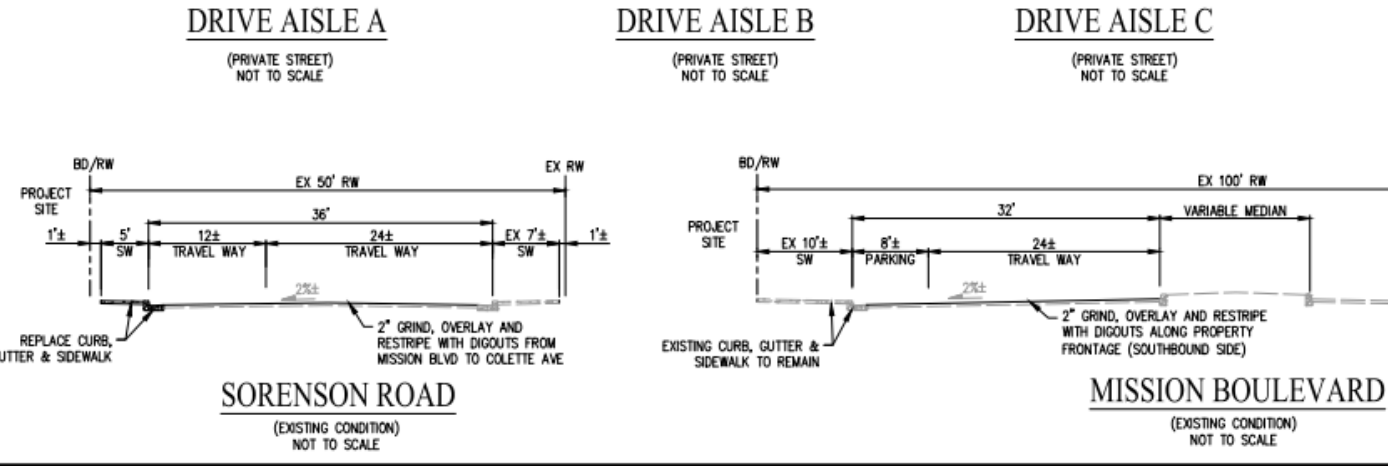
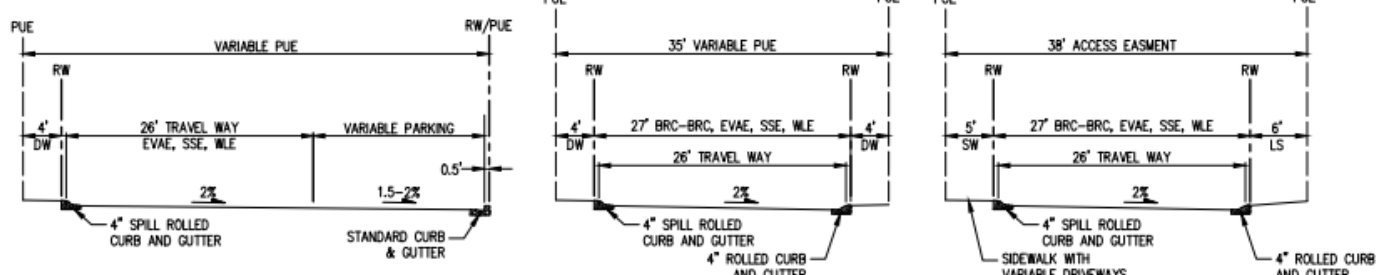

**VESTING TENTATIVE MAP  
FOR CONDOMINIUM PURPOSES  
SITE PLAN  
TELLES PROPERTY - TRACT 8335**

CITY OF HAYWARD ALAMEDA COUNTY CALIFORNIA

**cbg** Carlson, Barbee & Gibson, Inc. CIVIL ENGINEERS-SURVEYORS-PLANNERS

2633 CAMINO RAMON, SUITE 350 SAN RAMON, CALIFORNIA 94583 (925) 866-0322 www.cbgi.com

SHEET NO. **TM.2**

SCALE: 1" = 30' DATE: MAY 2017 JOB NO.: 2492-000

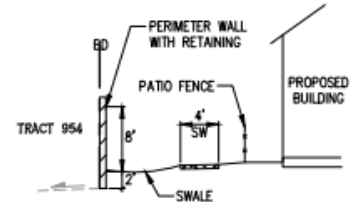

SECTION A-A  
NOT TO SCALE

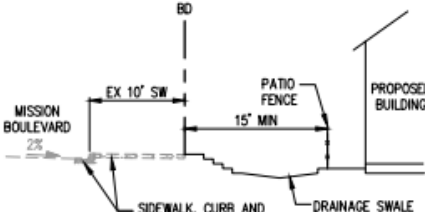

SECTION B-B  
NOT TO SCALE

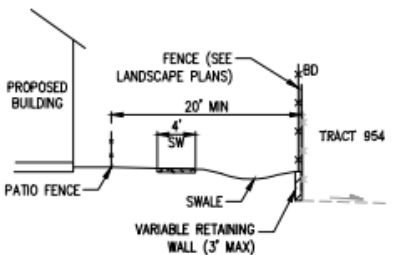

SECTION C-C  
NOT TO SCALE

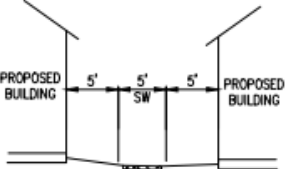

SECTION D-D  
NOT TO SCALE

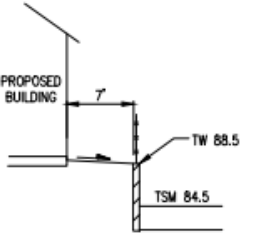

SECTION E-E  
NOT TO SCALE

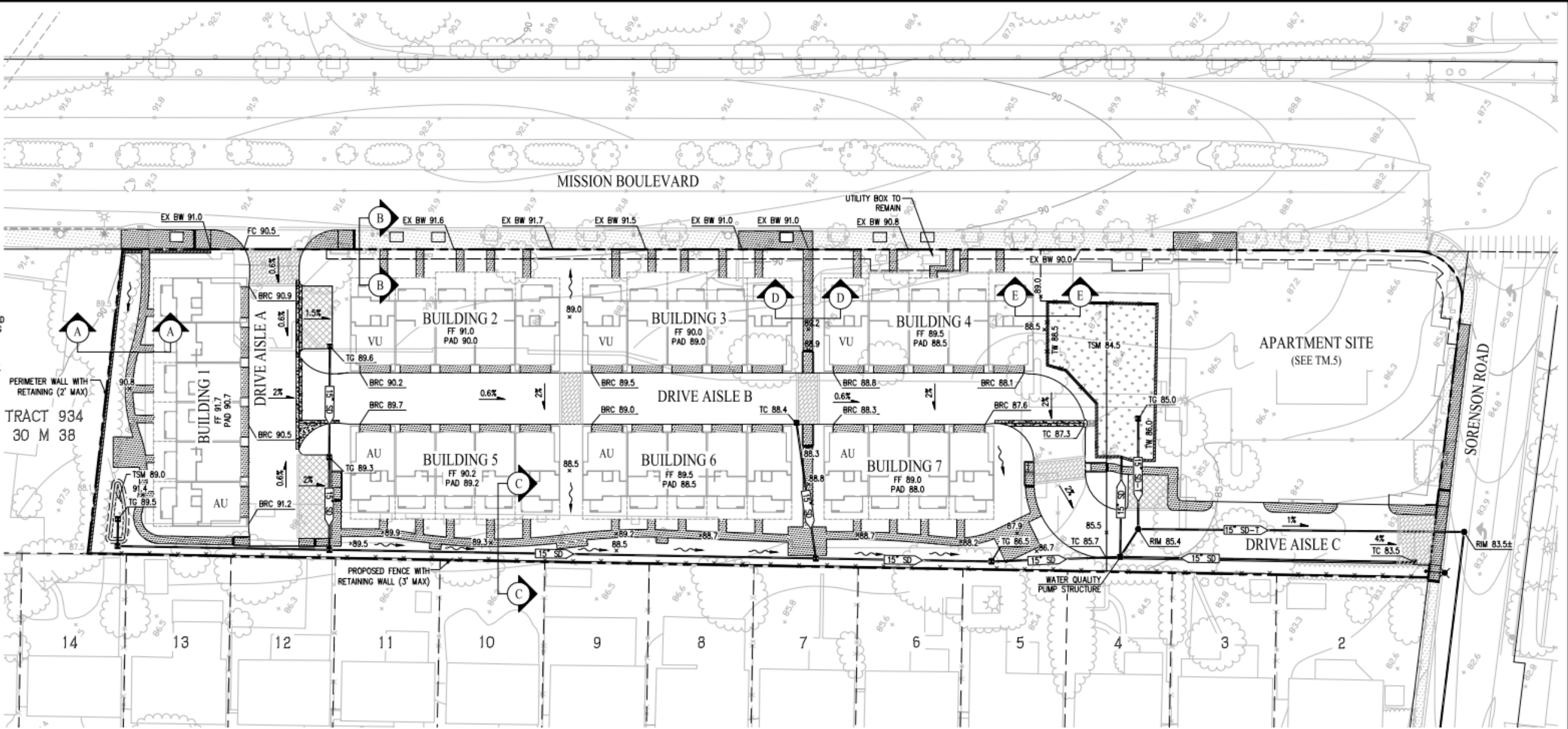

STREET	TI	R	HOT MIX ASPHALT (HSM)	CALTRANS CLASS 2 AGGREGATE BASE (AB)	TOTAL PAVEMENT THICKNESS
PRIVATE STREETS A, B, & C	5.5	5.0	4"	10"	14"

NOTES:  
1. R-VALUE TO BE FINALIZED BY GEOTECHNICAL ENGINEER WITH FINAL DESIGN.

DESCRIPTION	CUT	FILL
ROUGH GRADING	0 C.Y.	5,000 C.Y.

NOTES:  
1. EARTHWORK QUANTITIES ARE APPROXIMATE AND REPRESENT RAIN NUMBERS ONLY.  
2. EARTHWORK QUANTITIES DO NOT INCLUDE USING ROCK GENERATED FROM EXISTING PARKING AREA OR BUILDING FOUNDATION.  
3. ADDITIONAL MATERIALS MAY BE REQUIRED TO BALANCE.

**LEGEND**

EXISTING	PROPOSED	DESCRIPTION
---	---	SUBDIVISION BOUNDARY
---	---	RIGHT-OF-WAY
---	---	EASEMENT
---	---	PERIMETER MASONRY WALL
---	---	FENCE ON TOP OF RET WALL
---	---	FENCE
---	---	SIDEWALK
---	---	VALLEY GUTTER
---	---	BIORETENTION AREA
---	---	DECORATIVE PAVING
---	---	PERMEABLE PAVING
---	---	SPOT ELEVATIONS
---	---	STORM DRAIN LINE
---	---	STORM DRAIN MANHOLE (SDMH)
---	---	CATCH BASIN (CB)
---	---	FIELD INLET (FI)
---	---	CURB CUT

**ABBREVIATIONS**

AU	ACCESSIBLE UNIT
VU	VISITABLE UNIT
BRC	BACK OF ROLLED CURB
BD	BOUNDARY
EX	EXISTING
FF	FINISH FLOOR
GB	GRADE BREAK
HP	HIGH POINT
LP	LOW POINT
LS	LANDSCAPE
SD	STORM DRAIN
SW	SIDEWALK
TC	TOP OF CURB
TG	TOP OF GRATE

VESTING TENTATIVE MAP  
FOR CONDOMINIUM PURPOSES  
GRADING PLAN  
**TELLES PROPERTY - TRACT 8335**



CITY OF HAYWARD ALAMEDA COUNTY CALIFORNIA

**cbg** Carlson, Barbee & Gibson, Inc.  
CIVIL ENGINEERS-SURVEYORS-PLANNERS  
2633 CAMINO RAMON, SUITE 350  
SAN RAMON, CALIFORNIA 94583  
(925) 866-0322  
www.cbgi.com

SHEET NO.  
**TM.3**

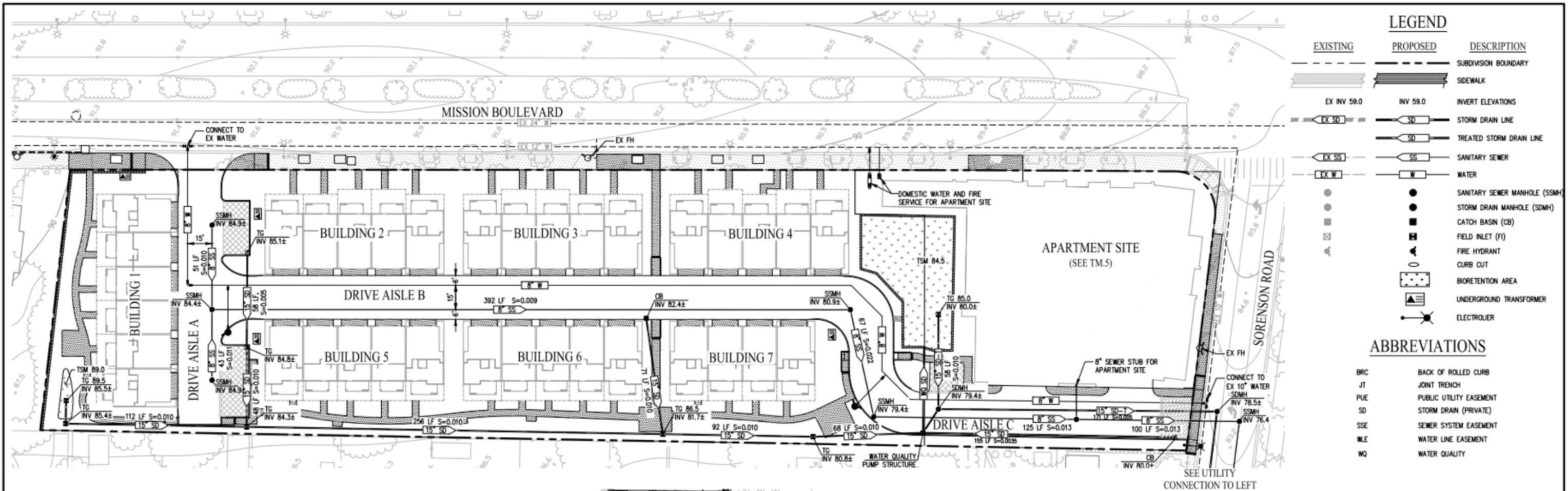

**UTILITY NOTES:**

- EXISTING UTILITIES** ALL EXISTING UTILITIES SERVING ORIGINAL USE WITHIN THE BOUNDARY TO BE REMOVED. EXISTING STORM DRAIN, SANITARY SEWER AND WATER WITHIN EASEMENTS TO REMAIN.
- PUBLIC UTILITIES** PROPOSED WATER AND SANITARY SEWER FACILITIES WITHIN PRIVATE ROADWAYS ARE PUBLIC AND WILL BE WITHIN A SANITARY AND/OR WATER EASEMENT. PROPOSED WATER AND SANITARY SEWER FACILITIES WILL BE CONSTRUCTED PER CITY OF HAYWARD STANDARDS AND BE DEDICATED TO THE CITY.
- PRIVATE UTILITIES** STORM DRAIN SYSTEM
- STORM DRAIN** PROPOSED ONSITE STORM DRAIN FACILITIES WILL BE PRIVATE AND WILL BE PRIVATELY MAINTAINED BY THE HOMEOWNER'S ASSOCIATION. MIN SLOPE OF PROPOSED STORM DRAIN PIPE = 0.0035. PUBLIC STORM DRAIN FACILITIES TO BE CONSTRUCTED TO CITY OF HAYWARD STANDARDS. ALL STORM PIPE TO BE RCP OR NDS N-12 PER CITY OF HAYWARD STANDARDS.
- WATER**
  - WATER SHALL BE CONSTRUCTED PER CITY OF HAYWARD STANDARDS
  - PROVIDE KEYS/ACCESS CODE/AUTOMATIC GATE OPENER TO UTILITIES FOR ALL METERS ENCLOSED BY A FENCE/GATE AS PER HAYWARD MUNICIPAL CODE 11-2.02.1. ONLY WATER DISTRIBUTION PERSONNEL SHALL PERFORM OPERATION OF VALVES ON THE HAYWARD WATER SYSTEM.
  - WATER AND SEWER SERVICE AVAILABLE SUBJECT TO STANDARD CONDITIONS AND FEES IN EFFECT AT TIME OF APPLICATION.
  - ALL WATER MAINS OUTSIDE OF ROADWAY OR UNDER DECORATIVE PAVEMENT TO BE DUCTILE IRON PIPE.
- SEWER** CITY OF HAYWARD STANDARD MIN SLOPE OF PROPOSED SEWER PIPE = 0.0075 MIN SIZE OF PROPOSED SEWER MAIN IS 8". SEWER SHALL BE CONSTRUCTED OF PVC PIPE PER CITY OF HAYWARD STANDARDS.
- GAS & ELECTRIC** PG&E
- TELEPHONE** SBC
- CABLE TV** COMCAST CABLE
- UTILITIES** UTILITIES SHOWN ARE TO BE USED AS A GUIDE AND MAY CHANGE DURING FINAL DESIGN. DESIGN SHALL ADHERE TO CITY OF HAYWARD STANDARDS.
- FIRE FLOW DATA** FIRE FLOW DATA (STATIC PRESSURE, RESIDUAL PRESSURE, PITOT PRESSURE, TEST FLOW, CALCULATED AVAILABLE WATER FLOW AT 20 PSI) SHALL BE SHOWN ON BUILDING PLANS SUBMITTAL. THE APPLICANT SHALL REQUEST FOR A NEW FIRE HYDRANT FLOW TEST IF AVAILABLE DATA IS MORE THAN 5 YEARS OLD. THE FIRE FLOW SHALL NOT BE LESS THAN 1,500 GPM.

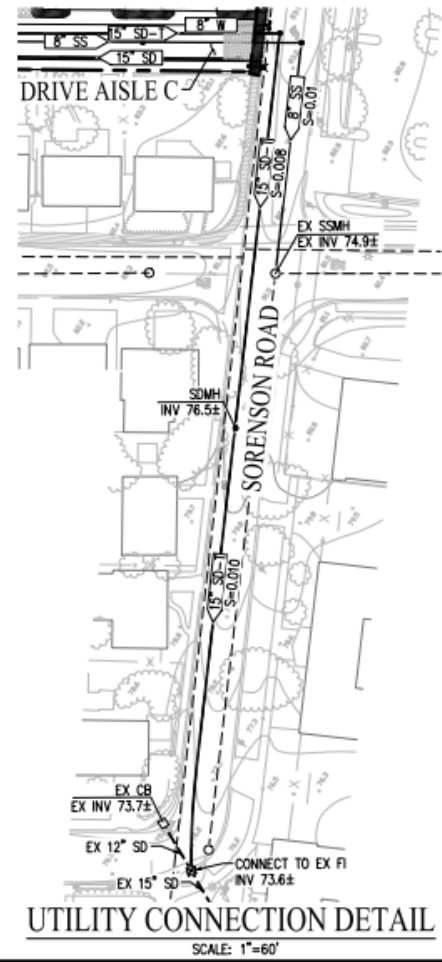
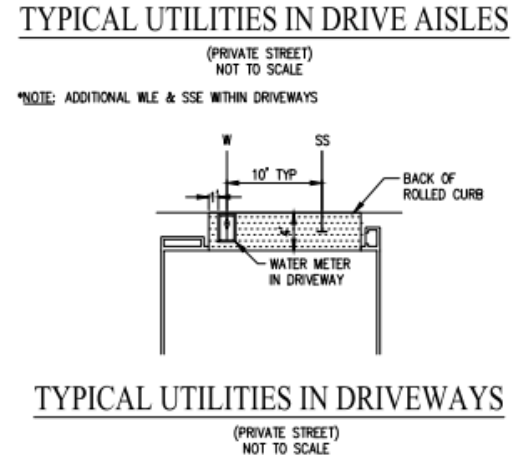
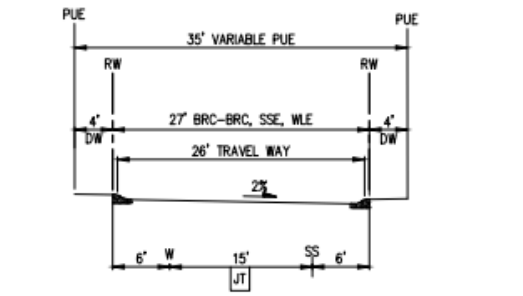

VESTING TENTATIVE MAP  
FOR CONDOMINIUM PURPOSES  
UTILITY PLAN  
**TELLES PROPERTY - TRACT 8335**

CITY OF HAYWARD ALAMEDA COUNTY CALIFORNIA

**cbg** Carlson, Barbee & Gibson, Inc. CIVIL ENGINEERS-SURVEYORS-PLANNERS  
2633 CAMINO RAMON, SUITE 350 SAN RAMON, CALIFORNIA 94583 (925) 866-0322 www.cbgi.com

SHEET NO. **TM.4**

SCALE: 1" = 30' DATE: APRIL 2017 JOB NO.: 2492-000

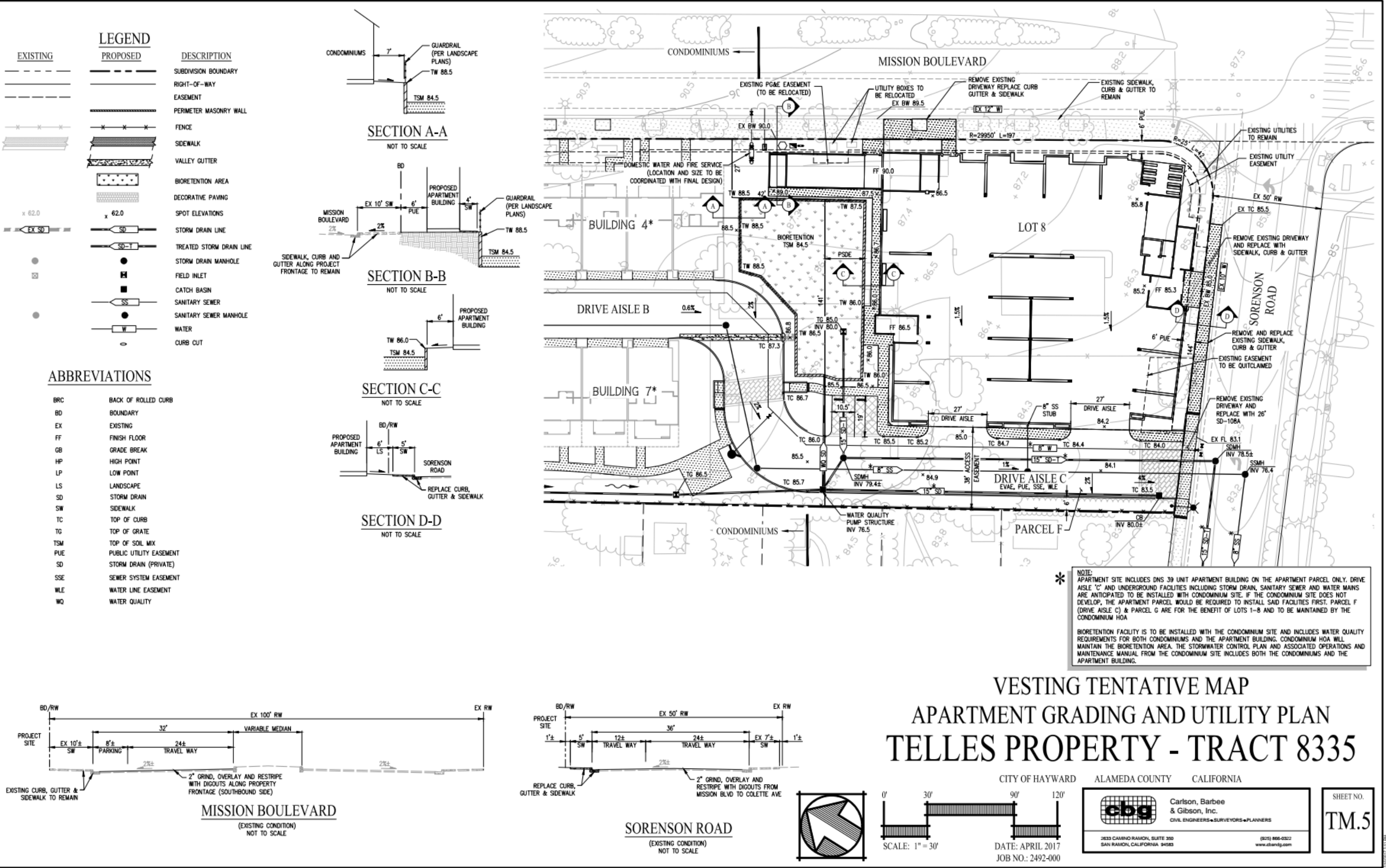

EXISTING	PROPOSED	DESCRIPTION
---	---	SUBDIVISION BOUNDARY
---	---	RIGHT-OF-WAY
---	---	EASEMENT
---	---	PERIMETER MASONRY WALL
---	---	FENCE
---	---	SIDEWALK
---	---	VALLEY GUTTER
---	---	BIORETENTION AREA
---	---	DECORATIVE PAVING
---	---	SPOT ELEVATIONS
---	---	STORM DRAIN LINE
---	---	TREATED STORM DRAIN LINE
---	---	STORM DRAIN MANHOLE
---	---	FIELD INLET
---	---	CATCH BASIN
---	---	SANITARY SEWER
---	---	SANITARY SEWER MANHOLE
---	---	WATER
---	---	CURB CUT

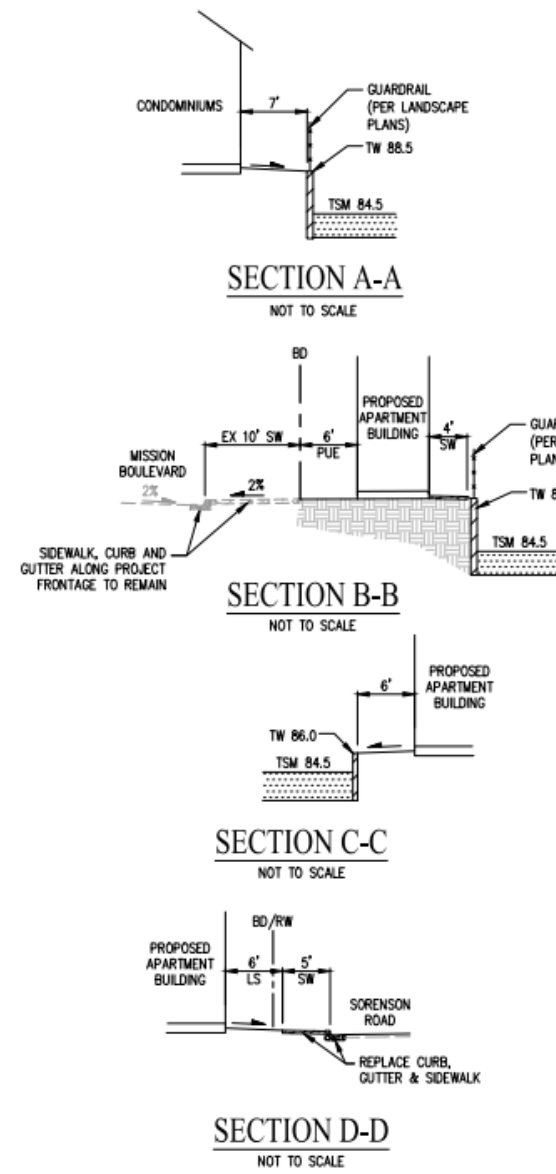

**ABBREVIATIONS**

BRC	BACK OF ROLLED CURB
BD	BOUNDARY
EX	EXISTING
FF	FINISH FLOOR
GB	GRADE BREAK
HP	HIGH POINT
LP	LOW POINT
LS	LANDSCAPE
SD	STORM DRAIN
SW	SIDEWALK
TC	TOP OF CURB
TG	TOP OF GRATE
TSM	TOP OF SOIL MIX
PUE	PUBLIC UTILITY EASEMENT
SD	STORM DRAIN (PRIVATE)
SSE	SEWER SYSTEM EASEMENT
WLE	WATER LINE EASEMENT
WQ	WATER QUALITY

**\* NOTE:**  
 APARTMENT SITE INCLUDES DNS 39 UNIT APARTMENT BUILDING ON THE APARTMENT PARCEL ONLY. DRIVE AISLE 'C' AND UNDERGROUND FACILITIES INCLUDING STORM DRAIN, SANITARY SEWER AND WATER MAINS ARE ANTICIPATED TO BE INSTALLED WITH CONDOMINIUM SITE. IF THE CONDOMINIUM SITE DOES NOT DEVELOP, THE APARTMENT PARCEL WOULD BE REQUIRED TO INSTALL SAID FACILITIES FIRST. PARCEL F (DRIVE AISLE C) & PARCEL G ARE FOR THE BENEFIT OF LOTS 1-8 AND TO BE MAINTAINED BY THE CONDOMINIUM HOA.  
 BIORETENTION FACILITY IS TO BE INSTALLED WITH THE CONDOMINIUM SITE AND INCLUDES WATER QUALITY REQUIREMENTS FOR BOTH CONDOMINIUMS AND THE APARTMENT BUILDING. CONDOMINIUM HOA WILL MAINTAIN THE BIORETENTION AREA. THE STORMWATER CONTROL PLAN AND ASSOCIATED OPERATIONS AND MAINTENANCE MANUAL FROM THE CONDOMINIUM SITE INCLUDES BOTH THE CONDOMINIUMS AND THE APARTMENT BUILDING.

# VESTING TENTATIVE MAP APARTMENT GRADING AND UTILITY PLAN TELLES PROPERTY - TRACT 8335

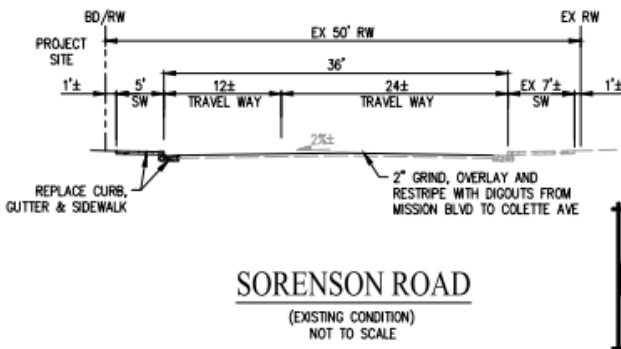
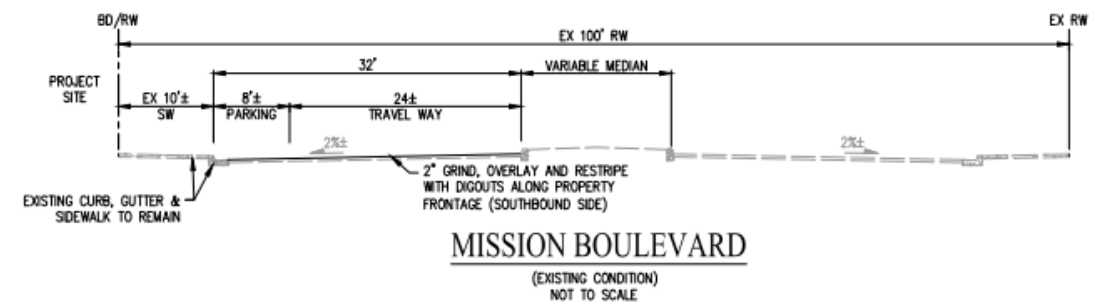

CITY OF HAYWARD ALAMEDA COUNTY CALIFORNIA  
 SCALE: 1" = 30'  
 DATE: APRIL 2017  
 JOB NO.: 2492-000

**cbg** Carlson, Barbee & Gibson, Inc.  
 CIVIL ENGINEERS • SURVEYORS • PLANNERS  
 2633 CAMINO RAMON, SUITE 350 SAN RAMON, CALIFORNIA 94583 (925) 866-0322 www.cbng.com

SHEET NO.  
**TM.5**

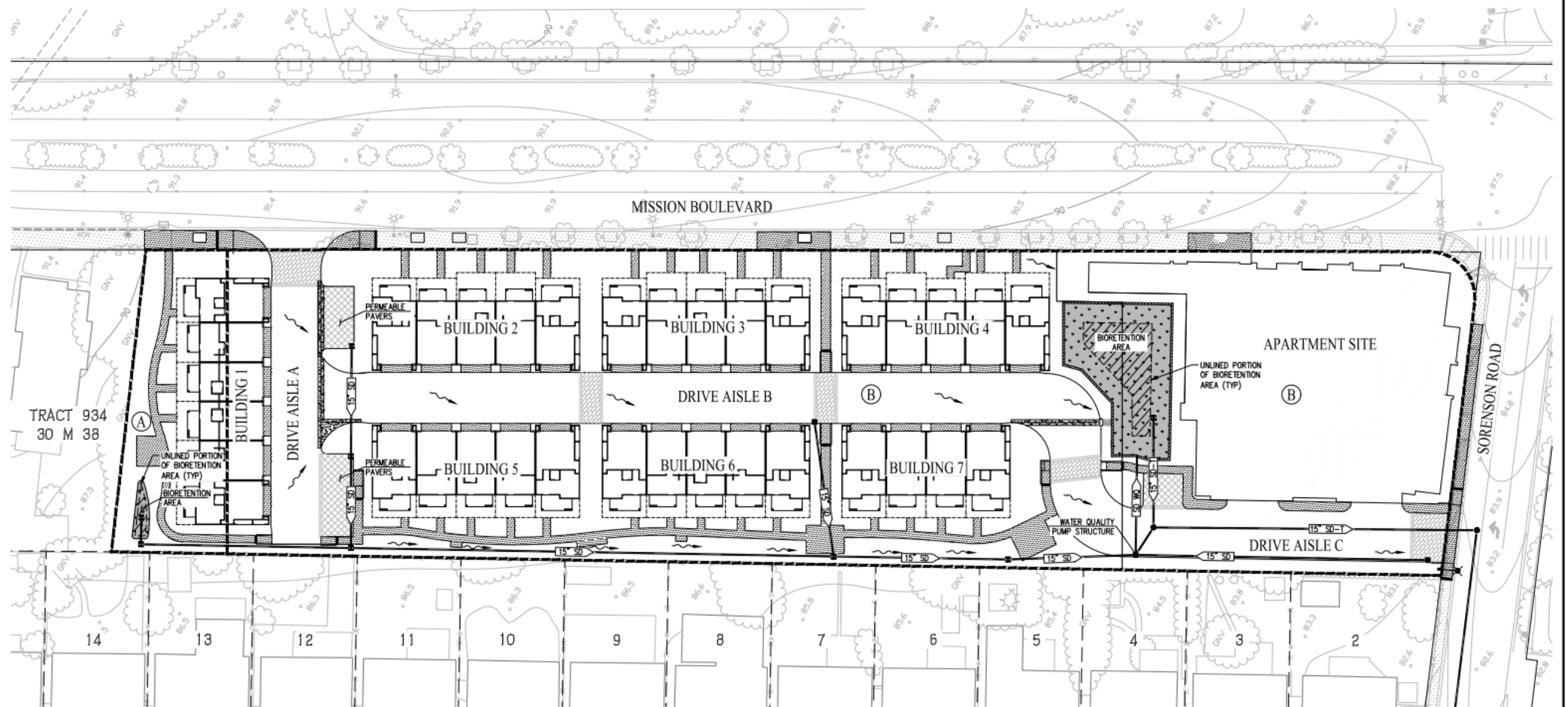

**LEGEND**

EXISTING	PROPOSED	DESCRIPTION
---	---	CURB, GUTTER & SIDEWALK
---	---	STORM DRAIN PIPE
---	---	TREATED STORM DRAIN PIPE
---	---	BIORETENTION AREA
---	---	UNLINED PORTION OF BIORETENTION AREA
---	---	DRAINAGE AREA BOUNDARY
(A)		DRAINAGE AREA ID
○		CURB CUT
→		DIRECTION OF FLOW
---	---	PERMEABLE PAVERS

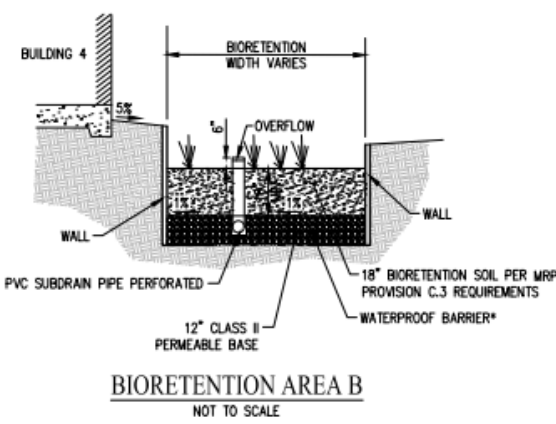
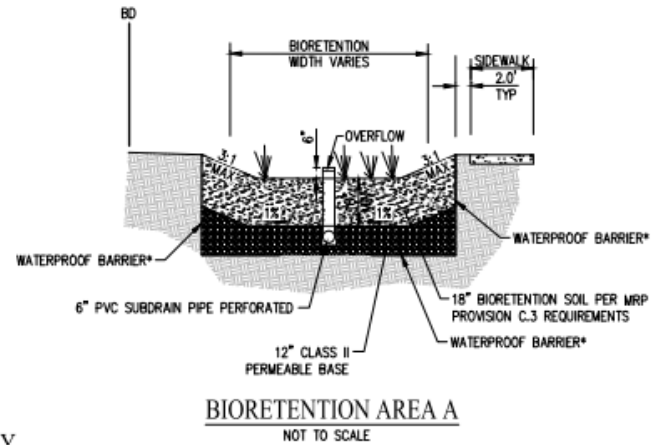

**NOTE:**  
BIORETENTION AREA (B) INCLUDES WATER QUALITY REQUIREMENTS FOR BOTH CONDOMINIUMS AND THE APARTMENT SITE. CONDOMINIUM HOA WILL MAINTAIN BOTH BIORETENTION AREAS. THE STORMWATER CONTROL PLAN AND ASSOCIATED OPERATIONS AND MAINTENANCE MANUAL WILL INCLUDE THE ENTIRE SITE AND BOTH BIORETENTION AREAS TOGETHER.

**PRELIMINARY STORMWATER TREATMENT SUMMARY**

AREA ID	TREATMENT TYPE	IMPERVIOUS AREA (SF)	TREATMENT AREA REQUIRED (SF)	TREATMENT AREA PROVIDED (SF)
A	BIORETENTION	4,560	197	230
B	BIORETENTION	81,360	3,365	3,400

\* INCLUDES FUTURE APARTMENT SITE

- \*NOTE:**
- INSTALL DEEPEINED CURBS IN ADDITION TO WATERPROOF BARRIER WHERE NECESSARY PER GEOTECHNICAL RECOMMENDATIONS
  - INSTALL 3" OF FLOAT-RESISTING MULCH ON EXPOSED SOIL AREAS BETWEEN PLANTINGS PER ALAMEDA COUNTY C.3 STORMWATER TECHNICAL GUIDANCE DATED JANUARY 1, 2015.

**VESTING TENTATIVE MAP  
STORMWATER CONTROL PLAN  
TELLES PROPERTY - TRACT 8335**

CITY OF HAYWARD ALAMEDA COUNTY CALIFORNIA

SCALE: 1" = 30'

DATE: APRIL 2017  
JOB NO.: 2492-000

Carlson, Barbee & Gibson, Inc.  
CIVIL ENGINEERS-SURVEYORS-PLANNERS

2633 CAMINO RAMON, SUITE 350  
SAN RAMON, CALIFORNIA 94583

(925) 866-0322  
www.cbgi.com

SHEET NO.  
**TM.6**

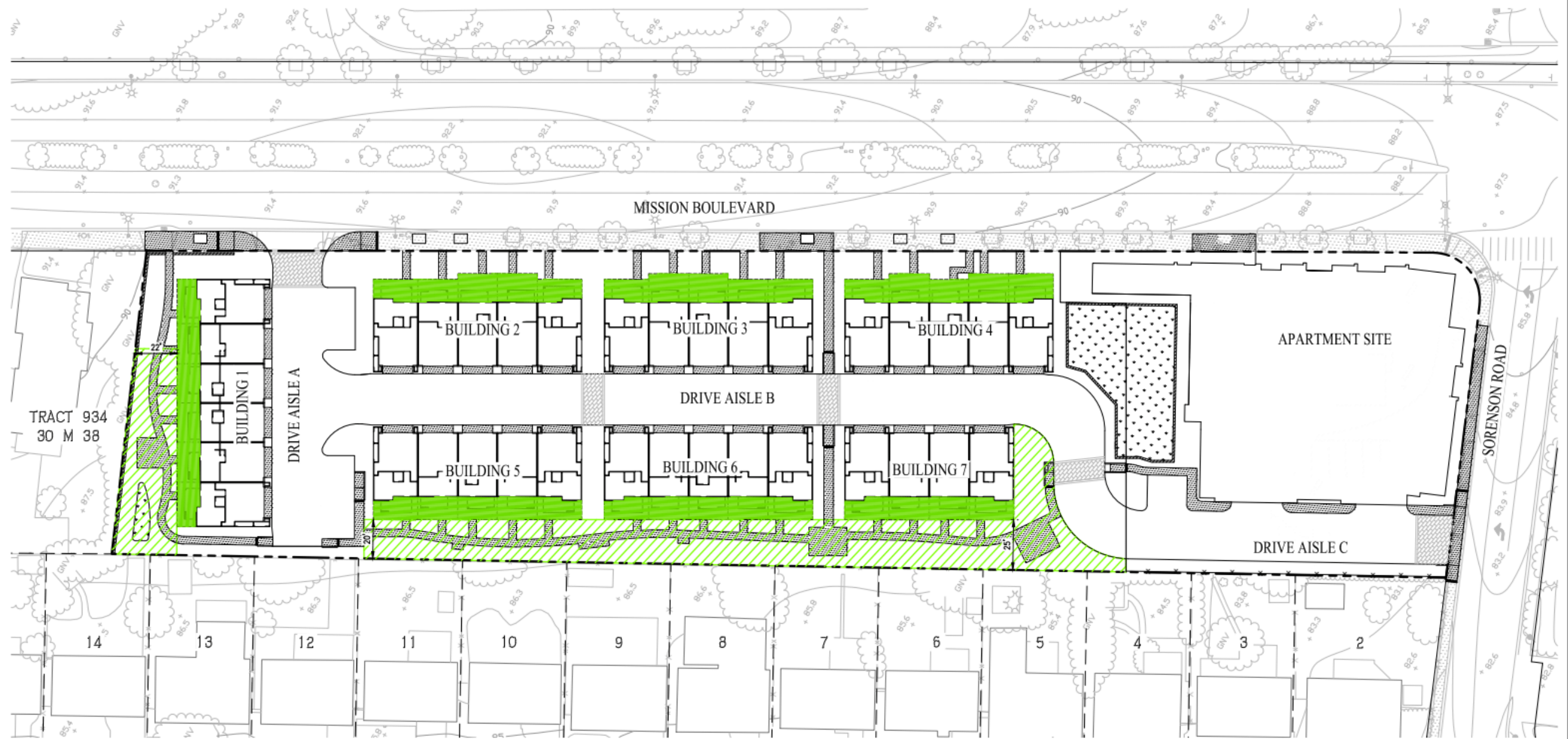

**LEGEND**

EXISTING	PROPOSED	DESCRIPTION
---	---	BOUNDARY
---	---	PRECAST WALL
---	---	FENCE
x 100.0	x 100.0	SPOT ELEVATIONS
		BIORETENTION AREA

OPEN SPACE AREA SUMMARY			
AREA TYPE	REQUIRED AREA (SF)	PROVIDED AREA (SF)	
	COMMON SPACE AREA 13,000 (15% OF LOT AREA)	13,250 SF (15% OF LOT AREA)	
	PRIVATE OPEN SPACE 3,500 (100 SF/UNIT)	9,500 (270 SF/UNIT)	

NOTE: APARTMENT SITE OPEN SPACE IS WITHIN THE APARTMENT BUILDING. SEE APARTMENT ARCHITECTURE.

OPEN SPACE EXHIBIT  
TELLES PROPERTY - TRACT 8335

CITY OF HAYWARD ALAMEDA COUNTY CALIFORNIA

SCALE: 1" = 30' DATE: APRIL 2017 JOB NO.: 2492-000

Carlson, Barbee & Gibson, Inc. CIVIL ENGINEERS • SURVEYORS • PLANNERS  
2533 CAMINO RAMON, SUITE 350 SAN RAMON, CALIFORNIA 94583 (925) 866-0322 www.cbgi.com

SHEET NO. C.1



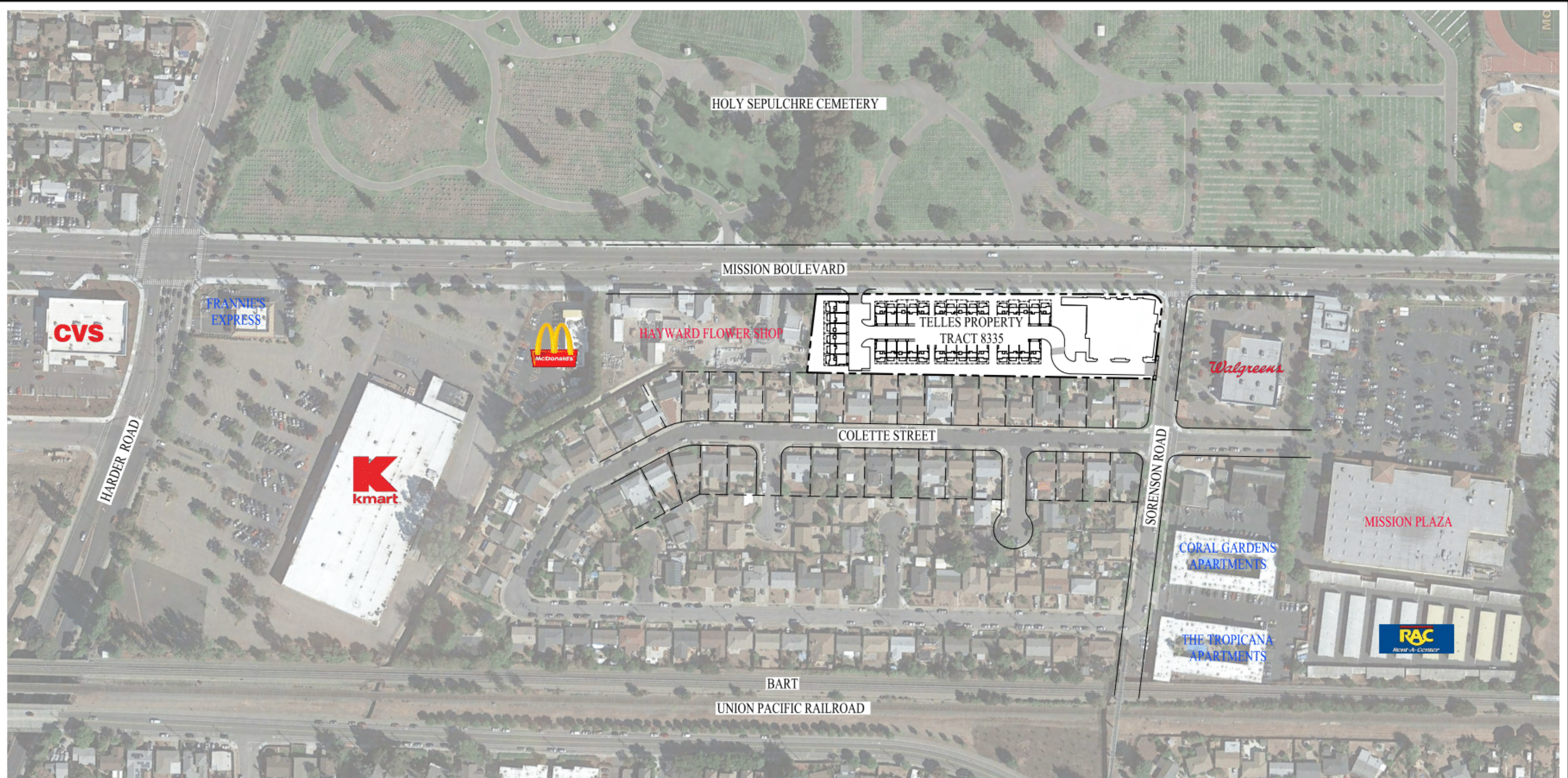

SITE CONTEXT EXHIBIT  
**TELLES PROPERTY - TRACT 8335**

CITY OF HAYWARD ALAMEDA COUNTY CALIFORNIA

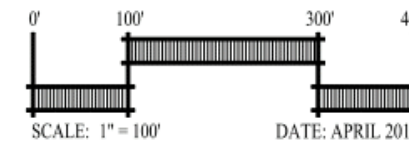
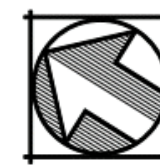

DATE: APRIL 2017  
 JOB NO.: 2492-000

**cbg** Carlson, Barbee & Gibson, Inc.  
 CIVIL ENGINEERS • SURVEYORS • PLANNERS  
 2633 CAMINO RAMON, SUITE 350 SAN RAMON, CALIFORNIA 94583 (925) 866-0322 www.cbgi.com

SHEET NO.  
**C.2**

# TELLES PROPERTY

## PLANNED DEVELOPMENT SUBMITTAL

### HAYWARD, CALIFORNIA

## PROJECT DIRECTORY

**CLIENT**  
 KB HOMES  
 5000 EXECUTIVE PARKWAY, SUITE 125  
 SAN RAMON, CA 94583  
 PH: (925) 983-4521  
 CONTACT: JOHN COMPAGLIA

**LANDSCAPE ARCHITECT**  
 GATES + ASSOCIATES  
 271 CROW CANYON ROAD  
 SAN RAMON, CA 94583  
 PH: (925) 736-8176  
 CONTACT: LINDA GATES

**CIVIL ENGINEER**  
 CARLSON, BARBEE & GIBSON  
 2633 CAMINO RAMON, SUITE 350  
 SAN RAMON, CA 94583  
 PH: (925) 866-0322  
 CONTACT: LEE ROSENBLATT

**ARCHITECT**  
 SDG ARCHITECTURE+ENGINEERING  
 3361 WALNUT BOULEVARD, SUITE 120  
 BRENTWOOD, CA 94513  
 PH: (925) 634-7000  
 CONTACT: RALPH STRAUSS

## SHEET INDEX

- L0.1-C COVER SHEET
- L0.2-C NOTES AND LEGENDS
- L0.3-C HYDROZONE PLAN
- L1.1-C EXISTING TREE SURVEY
- L2.1-C CONCEPTUAL LANDSCAPE PLAN
- L2.2-C LANDSCAPE ENLARGEMENT PLAN
- L3.1-C CONCEPTUAL LANDSCAPE DETAILS
- L3.2-C CONCEPTUAL LANDSCAPE DETAILS
- L3.3-C CONCEPTUAL LANDSCAPE DETAILS
- L3.4-C CONCEPTUAL LANDSCAPE DETAILS
- L4.1-C CONCEPTUAL IRRIGATION PLAN
- L4.2-C IRRIGATION NOTES AND LEGEND
- L4.3-C IRRIGATION DETAILS
- L4.4-C IRRIGATION DETAILS
- L4.5-C IRRIGATION DETAILS
- L4.6-C IRRIGATION DETAILS
- L4.7-C IRRIGATION CALCS

## PLANTING NOTES

1. ALL WORK SHALL BE PERFORMED BY PERSONS FAMILIAR WITH PLANTING WORK AND UNDER THE SUPERVISION OF A QUALIFIED PLANTING FOREMAN.
2. PLANT MATERIAL LOCATIONS SHOWN ARE DIAGRAMMATIC AND MAY BE SUBJECT TO CHANGE IN THE FIELD BY THE LANDSCAPE ARCHITECT.
3. ALL TREES ARE TO BE STAKED AS SHOWN ON THE TREE STAKING/GUYING DETAIL.
4. PLANT COUNT IS FOR THE CONVENIENCE OF THE CONTRACTOR. IN CASE OF DISCREPANCIES, THE PLAN SHALL GOVERN.
5. PLANT LOCATIONS ARE TO BE ADJUSTED IN THE FIELD AS NECESSARY TO SCREEN UTILITIES BUT NOT TO BLOCK WINDOWS NOR IMPEDE ACCESS.
6. THE LANDSCAPE ARCHITECT RESERVES THE RIGHT TO MAKE SUBSTITUTIONS, ADDITIONS, AND DELETIONS IN THE PLANTING SCHEME AS THEY FEEL NECESSARY WHILE WORK IS IN PROGRESS. SUCH CHANGES ARE TO BE ACCOMPANIED BY EQUITABLE ADJUSTMENTS IN THE CONTRACT PRICE IF WHEN NECESSARY.
7. BRANCHING HEIGHT OF TREES SHALL BE A 6'-0" MINIMUM ABOVE FINISH GRADE.
8. ALL TREES IN A FORMAL GROUP PLANTING SHALL BE MATCHING IN SIZE AND SHAPE.
9. LANDSCAPE CONTRACTOR SHALL HIRE AN ACCREDITED SOILS ANALYSIS FIRM TO TEST SOIL AND ABIDE BY RECOMMENDATIONS CONTAINED WITHIN FOR PROPER PLANT GROWTH.
10. ON GRADE PLANTING BACKFILL MIX SHALL CONSIST OF 50% IMPORTED TOPSOIL, 50% NATIVE SOIL (WITH NO ROCKS LARGER THAN 2" DIAMETER).
11. ALL ON-GRADE PLANTING AREAS ARE TO RECEIVE IRON AND NITROGEN STABILIZED REDWOOD SOIL CONDITIONER AT THE RATE OF 6 CUBIC YARDS/1000 SQUARE FEET, EVENLY TILLED 6" DEEP INTO THE SOIL TO FINISH GRADE.
12. ALL PLANTING AREAS SHALL BE TOP-DRESSED WITH 3" LAYER OF ORGANIC RECYCLED CHIP MULCH - DARK BROWN. THIS MULCH IS SUITABLE AS STABILIZING MULCH ON SLOPES GREATER THAN 4:1.
13. ALL STREET TREES TO BE INSTALLED IN ACCORDANCE WITH THE STANDARDS AND SPECIFICATIONS OF THE CITY.
14. ALL TREES WITHIN 5' OF PAVING AREAS SHALL HAVE DEEP ROOT BARRIERS INSTALLED. DEEP ROOT BARRIER MODEL NO. UB-38.2 (415) 344.1484.
15. THE LANDSCAPE CONTRACTOR SHALL AS A PART OF THIS BID PROVIDE FOR A PLANTING ALLOWANCE FOR THE AMOUNT OF \$1,500.00 (ONE THOUSAND FIVE HUNDRED DOLLARS), TO BE USED FOR SUPPLYING AND INSTALLING ADDITIONAL PLANT MATERIAL AS DIRECTED BY THE LANDSCAPE ARCHITECT AND APPROVED BY THE OWNER IN WRITING. THE UNUSED PORTION OF THE ALLOWANCE SHALL BE RETURNED TO THE OWNER AT THE BEGINNING OF THE MAINTENANCE PERIOD.
16. CONTRACTOR SHALL EXCAVATE ALL LIME-TREATED SOILS FROM ALL PLANTING AREAS.
17. ADJACENT TO CURBS OR PAVING, CONTRACTOR TO HOLD CENTER OF PLANTINGS 1/2 THE DISTANCE OF THE ON-CENTER SPACING.
18. THE LANDSCAPE CONTRACTOR IS TO PROVIDE AN AGRICULTURAL SUITABILITY ANALYSIS AND PERCOLATION TEST VERIFYING 3" PER HOUR DRAIN RATE FOR ON-SITE AND IMPORTED TOPSOIL. RECOMMENDATIONS FOR AMENDMENTS AND DRAINAGE SOLUTIONS CONTAINED IN THIS ANALYSIS, SHALL BE CARRIED OUT BEFORE PLANTING OCCURS IF DRAINAGE IS FOUND TO NOT AT A PROPER RATE.

## GENERAL NOTES

- UTILITIES ON SITE SHALL BE SCREENED BY EVERGREEN SHRUBS
- FOR BIO-RETENTION AREA CROSS-SECTION, SEE CIVIL DRAWINGS
- SCHEMATIC CONCEPT PLANS WERE BASE ON CITY OF HAYWARD'S WATER CONSERVATION IN LANDSCAPING REGULATIONS GUIDELINES AND CHECKLIST. FOLLOWING CITY'S APPROVAL OF PD SUBMITTAL DOCUMENTS, THE CONSTRUCTION DOCUMENTS SHALL ALSO FOLLOW CITY OF HAYWARD'S WATER CONSERVATION IN LANDSCAPING REGULATIONS GUIDELINES.

## LAYOUT NOTES

1. CONTRACTOR SHALL VERIFY ALL GRADES, EXISTING CONDITIONS AND DIMENSIONS IN THE FIELD PRIOR TO COMMENCING WORK ALL DISCREPANCIES OR QUESTIONS SHALL BE BROUGHT TO THE ATTENTION OF THE LANDSCAPE ARCHITECT FOR RESOLUTION.
2. ALL WRITTEN DIMENSIONS SUPERSEDE ALL SCALED DISTANCES AND DIMENSIONS. DIMENSIONS SHOWN ARE FROM THE FACE OF THE BUILDING, WALL, BACK OF CURB, EDGE OF WALK, PROPERTY LINE, OR CENTERLINE OF COLUMN UNLESS OTHERWISE NOTED ON THE DRAWINGS.
3. ALL ANGLES ARE 45 DEGREE, 90 DEGREE, OR 135 DEGREE UNLESS OTHERWISE NOTED.
4. ALL CURVES AND ALL TRANSITIONS BETWEEN CURVES AND STRAIGHT EDGES SHALL BE SMOOTH.
5. SEE IRRIGATION SCHEMATIC FOR GENERAL SYSTEM REQUIREMENTS AND FOR LOCATION OF IRRIGATION MAINLINE PIPING. SLEEVES TO ACCOMMODATE IRRIGATION PIPING, SIZED AS NEEDED, SHALL BE PLACED UNDER AND THROUGH SLABS AND WALLS, PRIOR TO POURING.
6. SCORE LINES IN SIDEWALKS SHALL BE SPACED TO EQUAL THE WIDTH OF THE WALKWAY, UNLESS OTHERWISE SHOWN. EXPANSION JOINTS IN SIDEWALKS SHALL BE 30' ON CENTER MAXIMUM AND AS SHOWN ON THE PLANS. EXPANSION JOINTS SHALL BE PLACED AT THE INTERFACE OF WALLS AND BUILDINGS AND AT THE CHANGE OF DIRECTION OF TRAVEL.
7. BUILDING LAYOUT AND LOCATION, SIDEWALK, CURB AND GUTTER, GRADING AND DRAINAGE IS BASED ON DRAWINGS PREPARED BY THE ARCHITECT AND THE CIVIL ENGINEER.
8. SEE ELECTRICAL ENGINEER'S PLANS AND LIGHTING PLAN FOR ADDITIONAL INFORMATION.
9. 6" CONCRETE MOW BAND SHALL BE INSTALLED IN BETWEEN THE SEAT WALL AND THE LAWN AREA, AS WELL AS ALONG THE EDGE OF THE RUBBER SURFACING PLAY AREA.
10. HANDRAILS ARE ONLY REQUIRED AT EACH RESIDENCE WHEN THE NUMBER OF RISERS IS 3 OR MORE.

## WATER EFFICIENT LANDSCAPE STATEMENT

I HAVE COMPLIED WITH THE CRITERIA OF THE CITY OF HAYWARD BAY FRIENDLY WATER EFFICIENT LANDSCAPE ORDINANCE AND APPLIED THEM FOR THE EFFICIENT USE OF WATER IN THE LANDSCAPE AND IRRIGATION DESIGN PLAN.

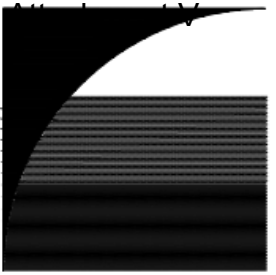

**GATES + ASSOCIATES**  
 LANDSCAPE ARCHITECTURE  
 LAND PLANNING • URBAN DESIGN  
 2671 CROW CANYON RD. SAN RAMON, CA 94583  
 T 925.736.8176 www.gates.com

## TELLES PROPERTY

HAYWARD  
 CALIFORNIA

ISSUE:	DESCRIPTION:	DATE:
ISSUE 1	PLAN REVIEW	04-23-18
ISSUE 2	2ND PLAN REVIEW	10-03-18
ISSUE 3	3RD PLAN REVIEW	01-19-17
ISSUE 4	4TH PLAN REVIEW	04-04-17
ISSUE 5	5TH PLAN REVIEW	06-30-17

NOT FOR CONSTRUCTION



PROJECT NUMBER: PROJECT #  
 DRAWN: BM  
 CHECK: MO  
 DATE: 04/02/2017  
 SCALE:



## LANDSCAPE NOTES

# L0.1-C

# PLANT LIST

TREES	BOTANICAL NAME	COMMON NAME	SIZE	SPACING	WATER USE (WUCOLS IV)	MATURE SIZE
AS	Acer rubrum 'Red Sunset'	Red Maple	24" Box	As Shown	M	30'-0"
AM	Arbutus 'Marina'	Arbutus Marina	24" Box	As Shown	L	30'-0"
CO	Cercis canadensis	Eastern Redbud	15 GAL	As Shown	VL	25'-0"
CT	Chitalpa x tashkentensis	NCN	24" Box	As Shown	L	25'-0"
ED	Elaeocarpus decipiens	Japanese Blueberry	15 GAL	As Shown	L	25'-0"
PC	Pistacia chinensis	Chinese Pistache	24" Box	As Shown	L	40'-0"
QA	Quercus agrifolia	Coast Live Oak	36" Box	As Shown	L	50'-0"
LM	Lagerstroemia hybrids 'Natchez'	Crape Myrtle	15 GAL	As Shown	L	12'-0"
PA	Platanus acerifolia 'Columbia'	London Plane Tree	36" Box	As Shown	M	30'-0"
TC	Tilia cordata	Little Leaf Linden	24" Box	As Shown	M	25'-0"
<b>SHRUBS</b>						
AD	Arctostaphylos densiflora 'Howard McMin'	Manzanita	5 Gal	6'-0" O.C.	L	7'-0"
BB	Berberis buxifolia 'Nana'	Dwarf Magellan Barberry	1 Gal	2'-0" O.C.	M	2'-0"
BW	Buddleja x weyeriana 'Bicolor'	Butterfly Bush	5 Gal	4'-6" O.C.	L	6'-0"
CS	Coleonema 'Sunset Gold'	Golden Breath of Heaven	1 Gal	3'-6" O.C.	M	4'-0"
DI	Dietses iridioides	African Iris	1 Gal	3'-0" O.C.	L	3'-0"
DV	Dietses grandiflora 'Variegata'	Striped Fortnight Lily	5 Gal	3'-0" O.C.	L	3'-0"
HS	Helictotrichon sempervirens	Blue Oat Grass	1 Gal	3'-0" O.C.	L	3'-0"
LA	Lavandula angustifolia 'Hidcote'	English Lavender	1 Gal	3'-0" O.C.	L	3'-0"
LL	Lomandra longifolia 'Breeze'	Dwarf Mat Rush	1 Gal	3'-0" O.C.	L	3'-0"
LU	Leucadendron 'Safari Sunset'	Safari Conebush	5 Gal	5'-0" O.C.	L	6'-0"
MC	Myrtus communis	Myrtle	5 Gal	3'-6" O.C.	L	4'-6"
PS	Pennisetum alopecuroides 'Hameln'	Dwarf Fountain Grass	1 Gal	3'-0" O.C.	L	3'-0"
PH	Penstemon heterophyllus 'Margarita BOP'	Margarita BOP	1 Gal	2'-6" O.C.	L	2'-6"
PY	Phormium 'Maori Sunrise'	Flax	1 Gal	5'-0" O.C.	M	5'-0"
PG	Phormium tenax 'Wings of Gold'	Dwarf Variegated Flax	1 Gal	3'-0" O.C.	L	3'-0"
PW	Pittosporum 'Wheeler Dwarf'	Dwarf Mock Orange	1 Gal	2'-6" O.C.	M	2'-6"
RY	Rosa 'Carpet Rose Yellow'	Yellow Carpet Rose	1 Gal	3'-0" O.C.	L	3'-6"
SE	Senecio madralescae	Blue Chalk Sticks	1 Gal	2'-0" O.C.	L	2'-0"
SM	Salvia microphylla 'Hot Lips'	Hot Lips Sage	1 Gal	3'-0" O.C.	L	3'-0"
TF	Teucrium fruticans 'Azureum'	Bush Germander	5 Gal	4'-0" O.C.	L	6'-0"
TL	Teucrium lucidrys 'Prostrata'	Groundcover Germander	1 Gal	3'-6" O.C.	L	4'-0"
<b>GROUNDCOVERS</b>						
CK	Coprosma x kirkii 'Variegata'	Creeping Coprosma	1 Gal	4'-0" O.C.	L	5'-0"
EG	Erigeron glaucus	Beach Aster	1 Gal	18" O.C.	L	18"
EK	Erigeron karvinskianus	Fleabane	1 Gal	2'-6" O.C.	L	3'-0"
GL	Grevillea lanigera 'Coastal Gem'	Grevillea	1 Gal	4' O.C.	L	4'-6"
LM	Lantana montevidensis	Creeping lantana	1 Gal	4' O.C.	L	4'-0"
MP	Myoporum parvifolium	Myoporum	1 Gal	6' O.C.	L	6'-0"
OF	Osteospermum fruticosum 'Cream Symphony'	African Trailing Daisy	1 Gal	3'-0" O.C.	L	3'-6"
RSS	Senecio serpens	Blue Chalksticks	1 Gal	18" O.C.	L	18" O.C.
<b>VINES</b>						
BB	Bougainvillea 'Barabara Karst'	Bougainvillea	5 Gal	As Shown	L	N/A
CC	Cytostoma callistegoides	Violet Trumpet Vine	5 Gal	As Shown	L	N/A
HV	Hardenbergia violacea	Hardenbergia	5 Gal	As Shown	L	N/A

**WATER USE RATING LEGEND:**  
 WUCOLS III CATEGORIES OF WATER NEEDS FROM: UNIVERSITY OF CALIF COOPERATIVE EXTENSION, CALIF DEPARTMENT OF WATER RESOURCES, U.S. BUREAU OF RECLAMATION  
 H = HIGH  
 M = MODERATE  
 L = LOW  
 VL = VERY LOW

# LAYOUT LEGEND

	PEDESTRIAN CONCRETE PAVING FINISH: MEDIUM BROOM COLOR: STANDARD GREY ALL PEDESTRIAN CONCRETE PAVING AT PATIO SHALL BE STANDARD GREY COLOR WITH SALT FINISH.	2 1.3.2-C
	PERMEABLE PAVERS AT PARKING MFR: BASALITE	
	STAMPED AC PAVING COLOR AND PATTERN: TBD	
	2 POST METAL ARBOR	1 1.3.4-C
	4 POST METAL ARBOR	2 1.3.4-C
	PICNIC TABLE MFR: LANDSCAPE FORMS PI: (800) 521-2546 MODEL: CHARLIE - ADA COMPLIANT 67" TABLE WITHOUT UMBRELLA HOLE COLOR: BLACK INSTALL PER MFG SPECS	
	BENCH MFR: LANDSCAPE FORMS PI: (800) 521-2546 MODEL: MAGGIE COLOR: BLACK INSTALL PER MFG SPECS	
	ENTRY MONUMENT AND WALL	6 1.3.3-C
	ENTRY MONUMENT	7 1.3.3-C
	COLUMN	2 1.3.3-C
	GRANITE BOULDER	3 1.3.2-C
	ORNAMENTAL PATIO FENCE	1 1.3.3-C
	CMU PERIMETER WALL	5 1.3.2-C
	6' ORNAMENTAL IRON FENCE	4 1.3.2-C
	FENCE AT BIO-RETENTION	8 1.3.3-C

# TREE LEGEND

Botanical Name	Common Name
Platanus acerifolia 'Columbia' <i>Existing Street Tree Species</i>	London Plane Tree
Pistacia chinensis	Chinese Pistachio
Arbutus 'Marina'	NCN
Lagerstroemia i. 'Natchez'	Crape Myrtle
Tilia cordata	Little Leaf Linden
Acer rubrum 'Red Sunset'	Red Maple
Chitalpa x tashkentensis	NCN
Elaeocarpus decipiens	Japanese Blueberry
Cercis canadensis	Eastern Redbud
Buddleja x weyeriana 'Bicolor'	Bicolor Butterfly Bush
Leucadendron 'Safari Sunset'	Safari Conebush

# PLANTING LEGEND

XX	TREE NAME
XX	QUANTITY
XX	SHRUB NAME
XX	QUANTITY
XX	GROUNDCOVER
--	QUANTITY
XX	VINE
XX	QUANTITY

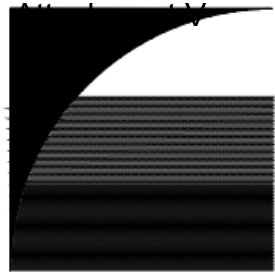

**GATES + ASSOCIATES**  
 LANDSCAPE ARCHITECTURE  
 LAND PLANNING • URBAN DESIGN  
 2671 CROW CANYON RD. SAN RAMON, CA 94583  
 T 925.776.8176 www.gates.com

**TELLES PROPERTY**

HAYWARD CALIFORNIA

ISSUE:	DESCRIPTION:	DATE:
ISSUE 1	PLAN REVIEW	04-23-18
ISSUE 2	2ND PLAN REVIEW	10-03-16
ISSUE 3	3RD PLAN REVIEW	01-19-17
ISSUE 4	4TH PLAN REVIEW	04-04-17
ISSUE 5	5TH PLAN REVIEW	06-30-17

**NOT FOR CONSTRUCTION**



PROJECT NUMBER:	PROJECT #
DRAWN:	BM
CHECK:	MO
DATE:	04/04/2017
SCALE:	



LANDSCAPE LEGEND

**L0.2-C**

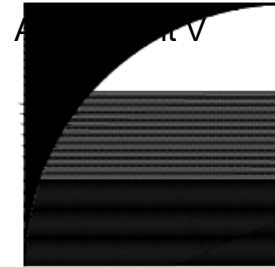

# GATES + ASSOCIATES

LANDSCAPE ARCHITECTURE  
LAND PLANNING • URBAN DESIGN  
2671 CROW CANYON RD. SAN RAMON, CA 94583  
T 925.716.1176 www.gates.com

## TELLES PROPERTY

HAYWARD  
CALIFORNIA

ISSUE	DESCRIPTION	DATE
ISSUE 1	PLAN REVIEW	04-22-16
ISSUE 2	2ND PLAN REVIEW	10-03-16
ISSUE 3	3RD PLAN REVIEW	01-19-17
ISSUE 4	4TH PLAN REVIEW	04-04-17
ISSUE 5	5TH PLAN REVIEW	06-30-17

**NOT FOR CONSTRUCTION**

*Daniel Gates*  
03/12/2017  
02/08/2016

PROJECT NUMBER: PROJECT #  
DRAWN: BM  
CHECK: MO  
DATE: 04/04/2017  
SCALE: 1" = 20'-0"



### HYDROZONE PLAN

# L0.3-C

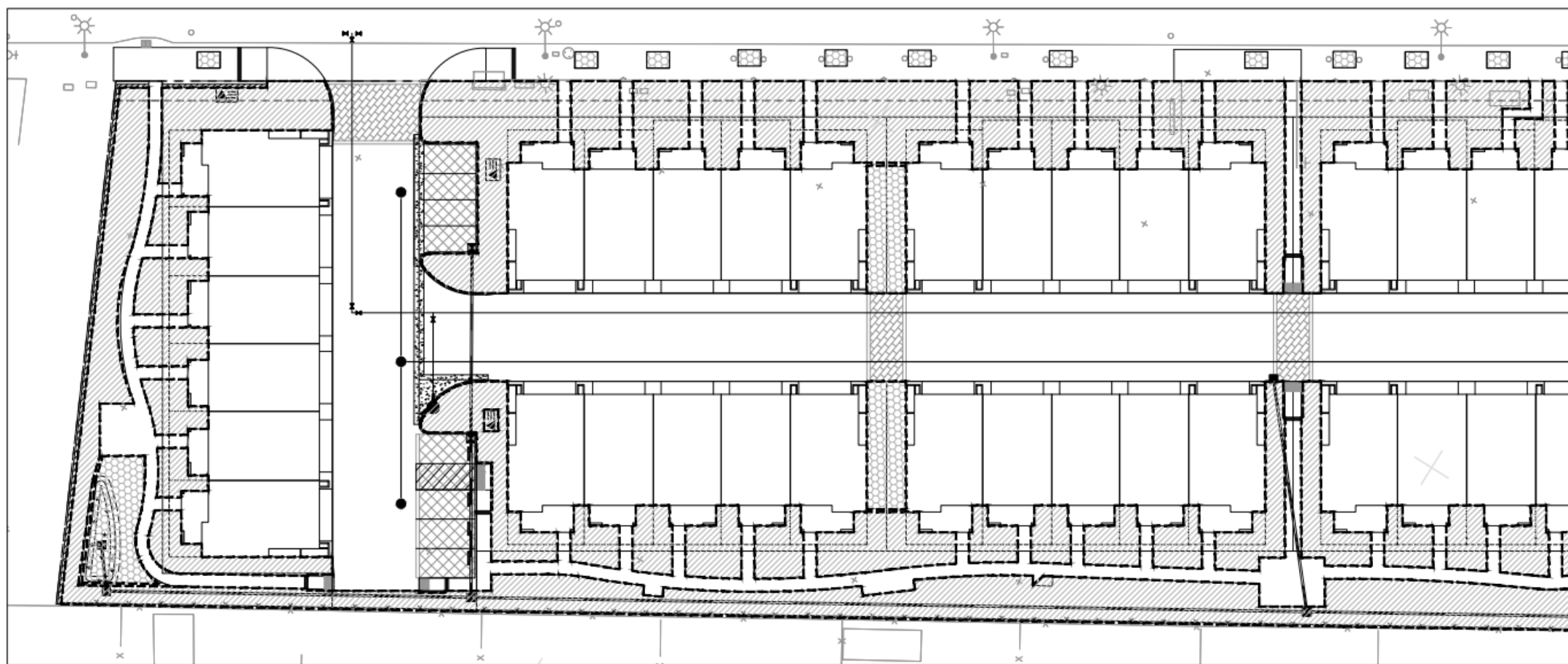

MATCHLINE - SEE BOTTOM LEFT

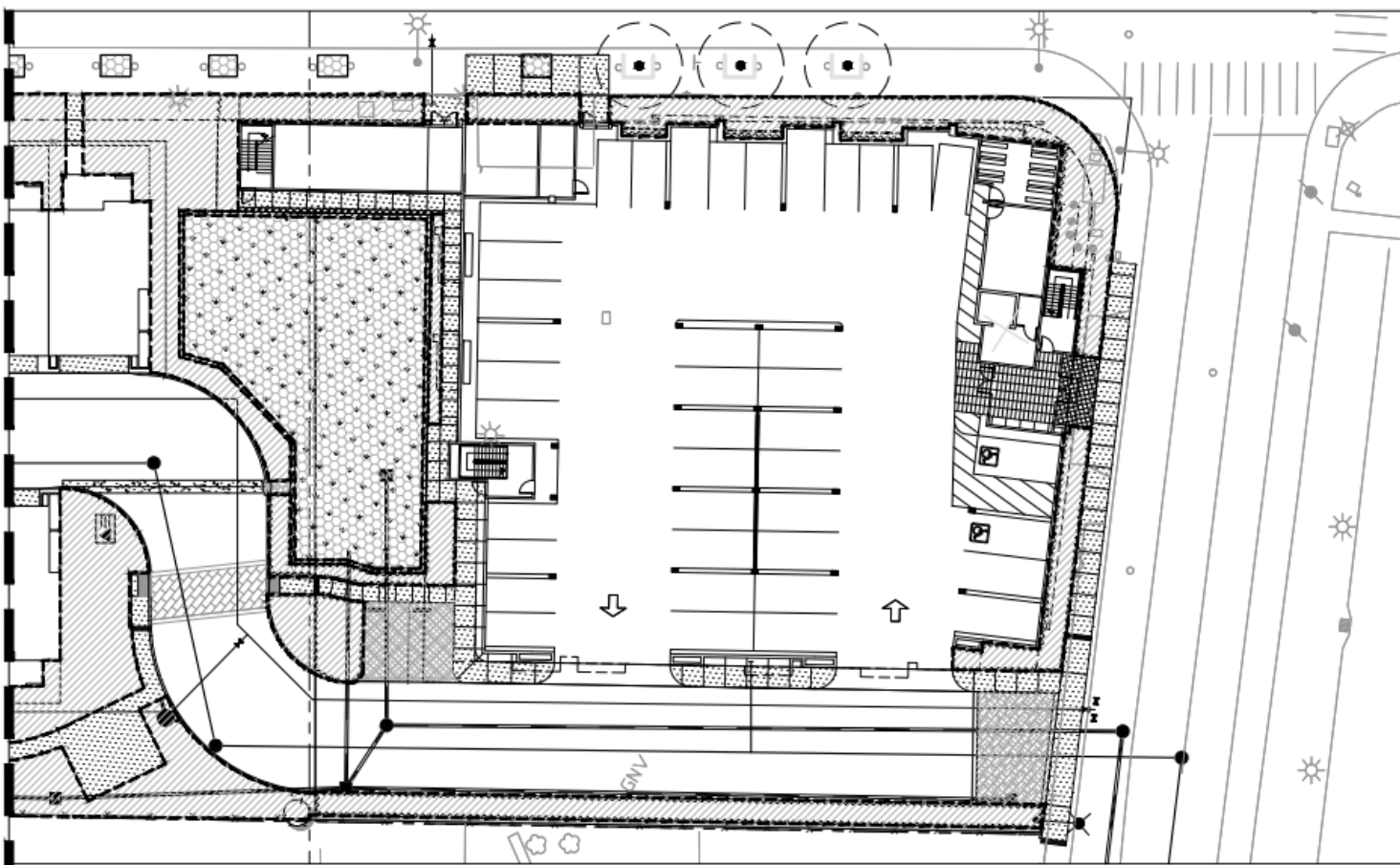

MATCHLINE - SEE TOP

### HYDROZONE LEGEND

A	LOW WATER USE	29,796 SF	88%
B	MODERATE WATER USE	4,199 SF	12%
TOTAL PLANTING AREA		33,995 SF	100%

EXISTING STREET TREE ASSESSMENT CHART



STREET TREE MITIGATION SUMMARY CHART:

Recommendations for Action, Telles property, Hayward					Recommendations for Action, continued, Telles property, Hayward				
Tree #	Species	Trunk Diameter	Protected?	Impacts	Tree #	Species	Trunk Diameter	Protected?	Impacts
568	Hackberry	14	Yes	Remove, within N. develop. parcel	585	London plane	5	Yes	Preserve, street tree
569	Hackberry	10	Yes	Remove, within N. develop. parcel	586	London plane	4	Yes	Preserve, street tree
570	Hackberry	11	Yes	Remove, within N. develop. parcel	587	London plane	4	Yes	Preserve, street tree
571	Hackberry	11	Yes	Remove, within N. develop. parcel	588	London plane	4	Yes	Preserve, street tree
572	Hackberry	11	Yes	Remove, within N. develop. parcel	589	London plane	4	Yes	Preserve, street tree
573	Hackberry	11	Yes	Remove, within N. develop. parcel	590	London plane	5	Yes	Preserve, street tree
574	Hackberry	9	Yes	Remove, within N. develop. parcel	591	London plane	4	Yes	Preserve, street tree
575	Hackberry	11	Yes	Remove, within N. develop. parcel	592	London plane	4	Yes	Preserve, street tree
576	Hackberry	14	Yes	Remove, within S. remainder parcel	593	Calif. black walnut	24,20	Yes	Preserve, off-site
577	Hackberry	6	No	Remove, within S. remainder parcel	594	Calif. pepper	36	Yes	Preserve, off-site
578	Hackberry	9	Yes	Remove, within S. remainder parcel	595	Holly oak	8	Yes	Preserve, off-site
579	Hackberry	11	Yes	Remove, within S. remainder parcel	596	Privet	4,3,3,2,2,1	Yes	Preserve, off-site
580	Hackberry	9	Yes	Remove, within S. remainder parcel	597	Avocado	9	Yes	Preserve, off-site
581	Blackwood acacia	20	Yes	Remove, within S. remainder parcel	598	Peach	4,3,3,2	Yes	Preserve, off-site
582	London plane	5	Yes	Preserve, street tree	599	Coast live oak	30	Yes	Preserve, off-site
583	London plane	4	Yes	Preserve, street tree					
584	London plane	5	Yes	Preserve, street tree					

	QUANTITY	APPRAISED VALUE	MITIGATION MEASURE
TREES TO BE REMOVED	32	\$8,450 (Total APPRAISED VALUE)	(7)XS150/ UPSIZED 36 BOX STREET TREE = \$1,050 (Platanus acerifolia) (15)XS350/ 36" BOX TREE = \$5,250 (Quercus agrifolia)
TREES TO BE PRESERVED IN PLACE	18	\$33,444	N/A
TOTAL MITIGATION TREES	31		
TOTAL MITIGATION VALUE			\$6,300

NOTE: REFER TO ARBORIST TREE ASSESSMENT AND APPRAISAL REPORT DATED AUGUST 15, 2016 PREPARED BY HORT SCIENCE FOR DETAILED INFORMATION ON TREE ASSESSMENT CHART, TREE APPRAISAL AND TREE PROTECTION PLAN.

LEGEND

-  TREES TO BE REMOVED
-  TREES TO BE PRESERVED IN PLACE

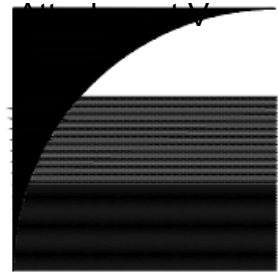
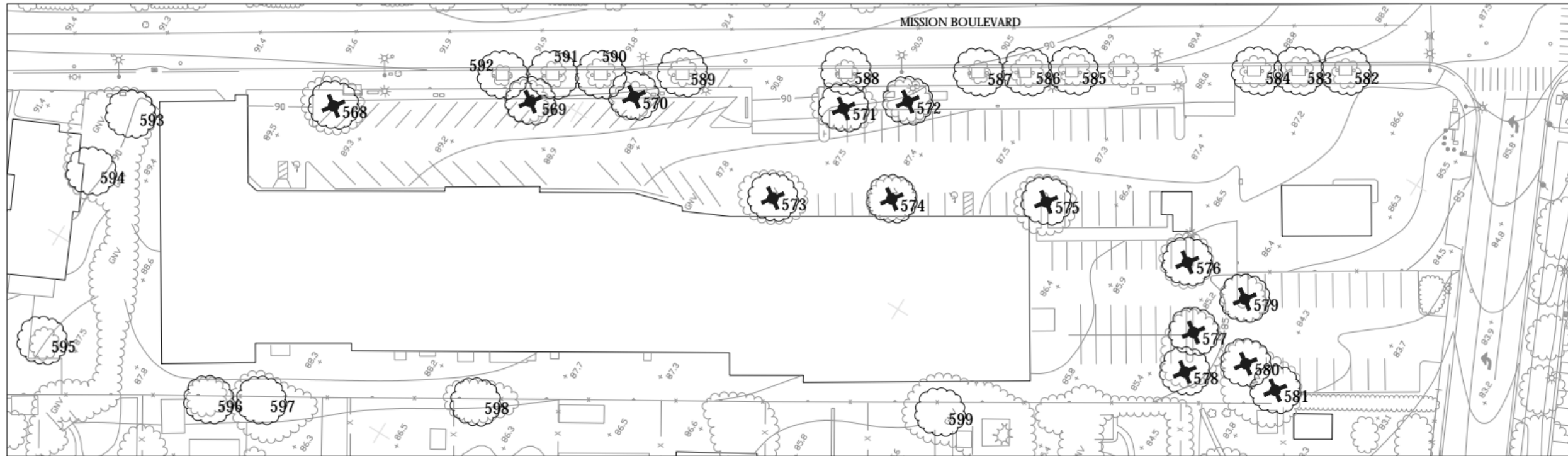

**GATES + ASSOCIATES**  
 LANDSCAPE ARCHITECTURE  
 LAND PLANNING • URBAN DESIGN  
 2671 CROW CANYON RD. SAN RAMON, CA 94583  
 T 925.776.8176 www.gates.com

**TELLES PROPERTY**

HAYWARD CALIFORNIA

ISSUE:	DESCRIPTION:	DATE:
ISSUE 1	PLAN REVIEW	04-23-18
ISSUE 2	2ND PLAN REVIEW	10-03-18
ISSUE 3	3RD PLAN REVIEW	01-19-17
ISSUE 4	4TH PLAN REVIEW	04-04-17
ISSUE 5	5TH PLAN REVIEW	06-30-17

**NOT FOR CONSTRUCTION**



PROJECT NUMBER: PROJECT #  
 DRAWN: BM  
 CHECK: MO  
 DATE: 04/04/2017  
 SCALE:



EXISTING TREE SURVEY

**L1.1-C**

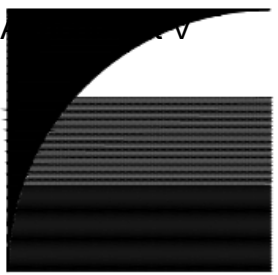

**GATES**  
+ ASSOCIATES  
LANDSCAPE ARCHITECTURE  
LAND PLANNING • URBAN DESIGN  
2671 CROW CANYON RD., SAN RAMON, CA 94583  
T 925.736.8176 www.gates.com

**TELLES**  
PROPERTY

HAYWARD  
CALIFORNIA

ISSUE	DESCRIPTION	DATE
ISSUE 1	PLAN REVIEW	04-22-16
ISSUE 2	2ND PLAN REVIEW	10-03-16
ISSUE 3	3RD PLAN REVIEW	01-19-17
ISSUE 4	4TH PLAN REVIEW	04-04-17
ISSUE 5	5TH PLAN REVIEW	06-30-17

**NOT FOR  
CONSTRUCTION**



PROJECT NUMBER: PROJECT #  
DRAWN: BM  
CHECK: MO  
DATE: 04/04/2017  
SCALE: 1" = 20'-0"



LANDSCAPE CONCEPT

**L2.1-C**

**TREE LEGEND**

Botanical Name	Common Name	Botanical Name	Common Name
Platanus acerifolia 'Columbia'	London Planetree	Acer rubrum 'Red Sunset'	Red Maple
Platanus acerifolia	Existing Street Tree Species	Clitropa x tashkentensis	NCN
Pistacia chinensis	Chinese Pistacho	Elaeocarpus decipiens	Japanese Blueberry
Arbutus 'Marina'	NCN	Cercis canadensis	Eastern Redbud
Lagerstroemia 'Natchez'	Crape Myrtle	Arctostaphylos densiflora 'Howard McMill'	Manzanita
Tilia cordata	Little Leaf Linden	Buddleja x weyeriana 'Bicolor'	Bicolor Butterfly Bush
● S85	Existing Tree to Remain	Leucadendron 'Safari Sunset'	Safari Conebush

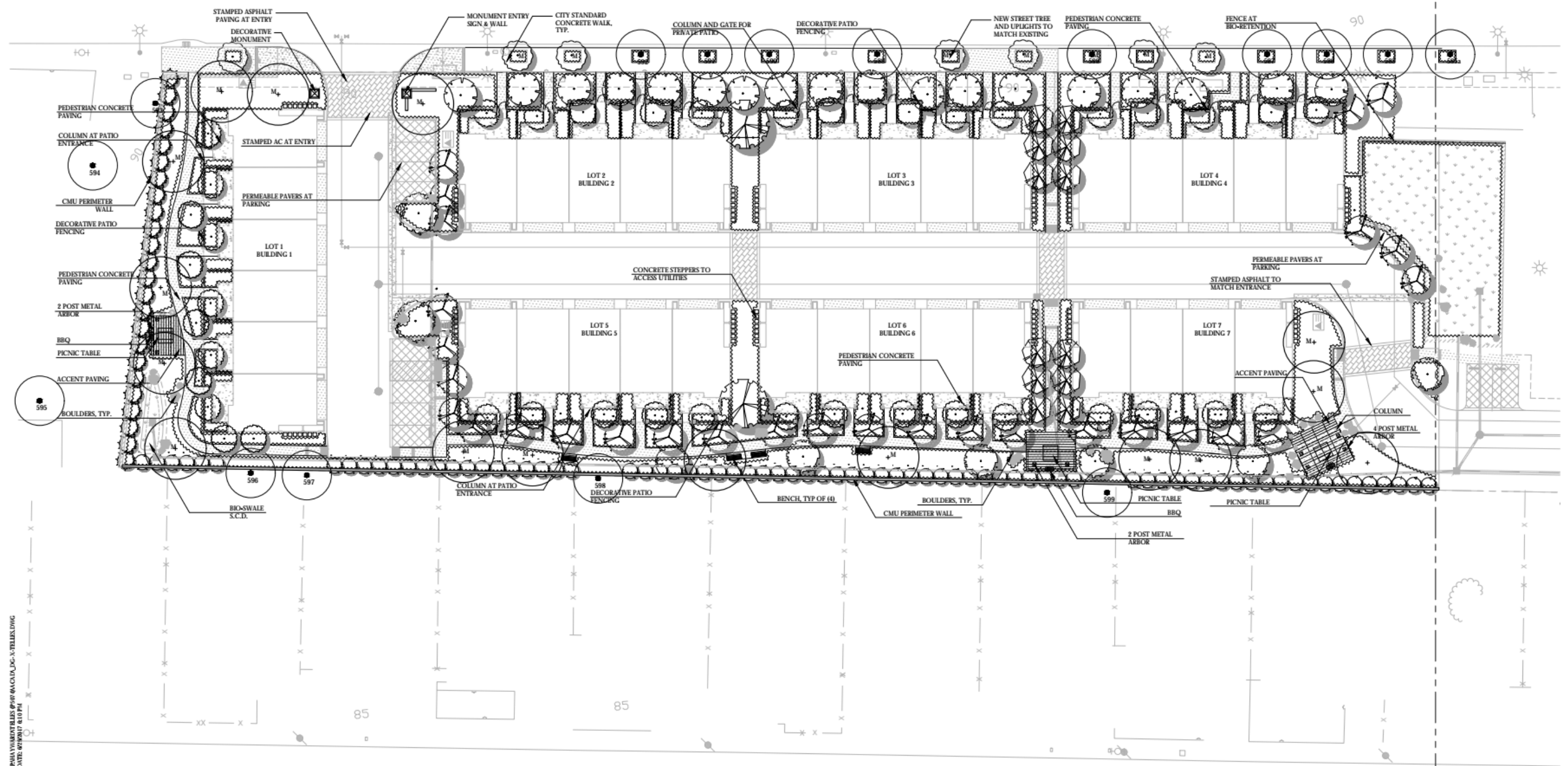

DATE: 04/04/2017 10:54 AM FILED: 04/04/2017 10:54 AM PROJECT: TELLES PROPERTY L2.1-C

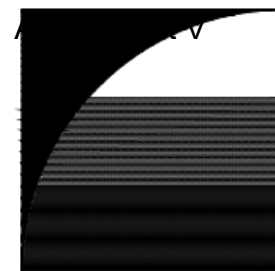

**GATES**  
**+ASSOCIATES**  
 LANDSCAPE ARCHITECTURE  
 LAND PLANNING • URBAN DESIGN  
 2871 CROW CANYON RD., SAN RAMON, CA 94583  
 T 925.736.8176 www.gates.com

**TELLES**  
**PROPERTY**

HAYWARD  
 CALIFORNIA

ISSUE	DESCRIPTION	DATE
ISSUE 1	PLAN REVIEW	04-22-16
ISSUE 2	2ND PLAN REVIEW	10-03-16
ISSUE 3	3RD PLAN REVIEW	01-19-17
ISSUE 4	4TH PLAN REVIEW	04-04-17
ISSUE 5	5TH PLAN REVIEW	06-30-17

**NOT FOR  
 CONSTRUCTION**



PROJECT NUMBER: PROJECT #  
 DRAWN: BM  
 CHECK: MO  
 DATE: 04/04/2017  
 SCALE: AS SHOWN



LANDSCAPE CONCEPT  
 ENLARGEMENT

**L2.2-C**

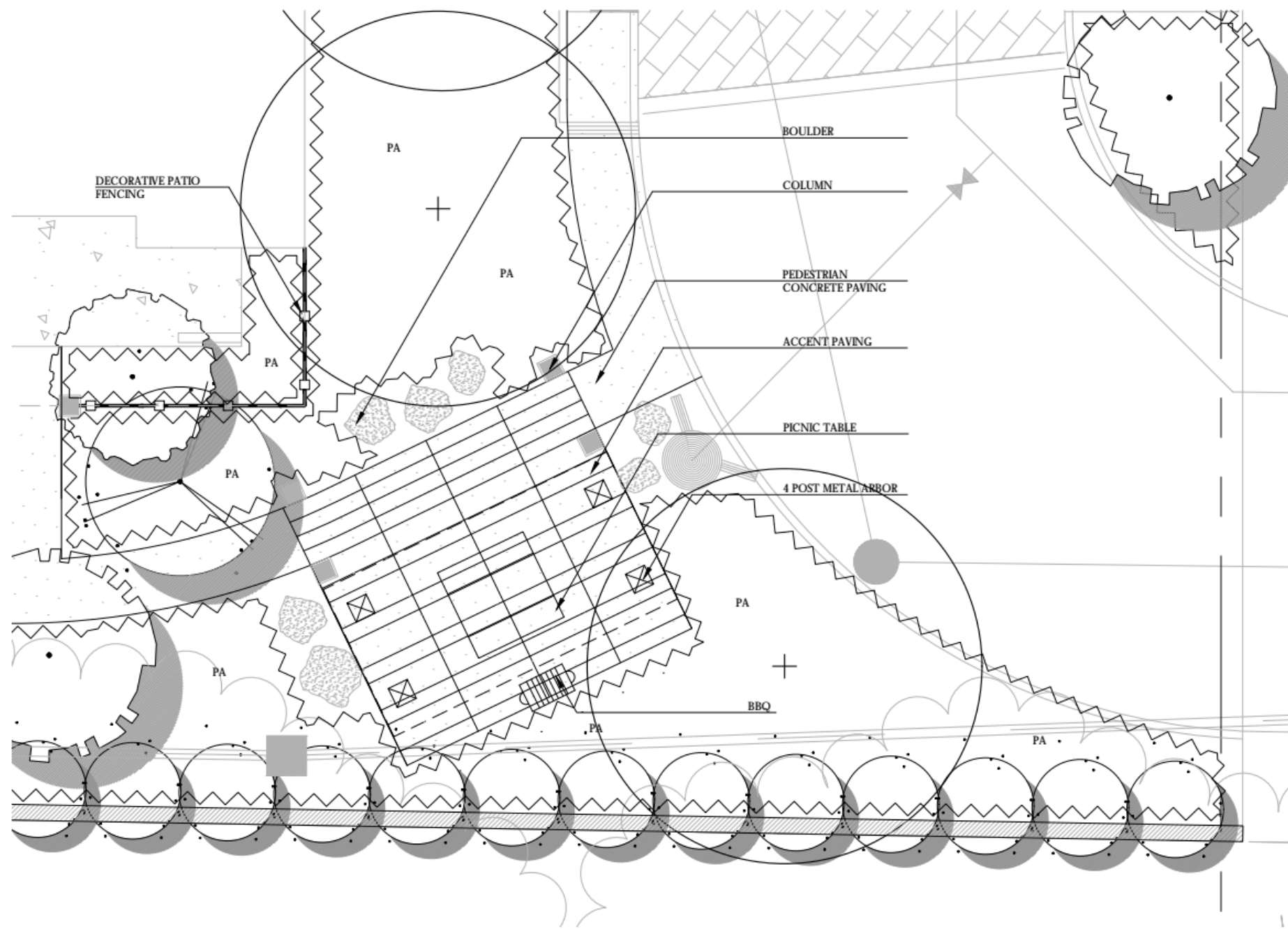

**COMMON AREA ENLARGEMENT PLAN**  
 SCALE: 1" = 10'-0"

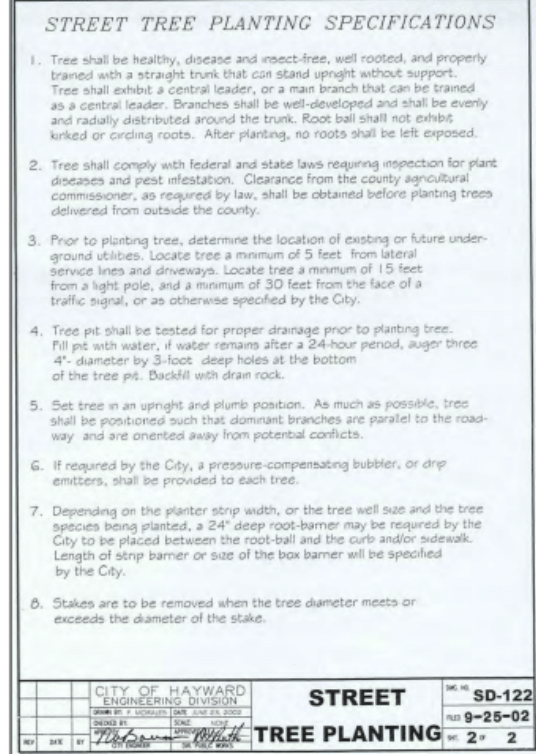
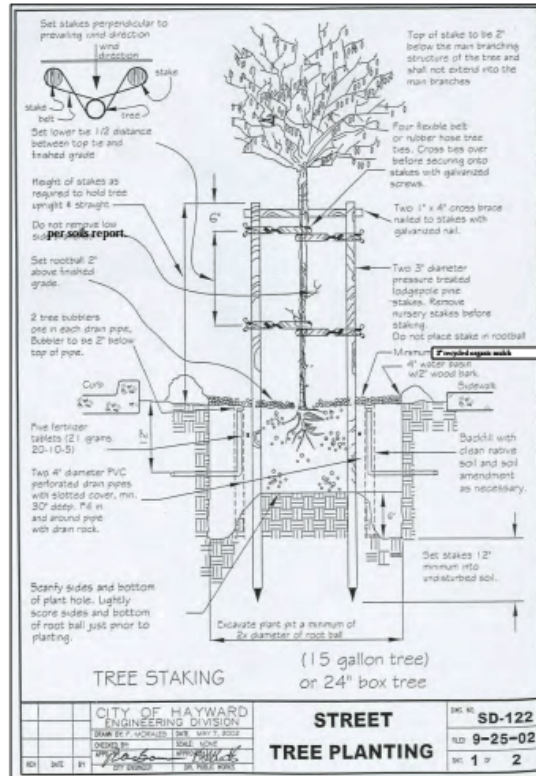

**6 STREET TREE PLANTING**  
 SCALE: 1" = 1'-0"

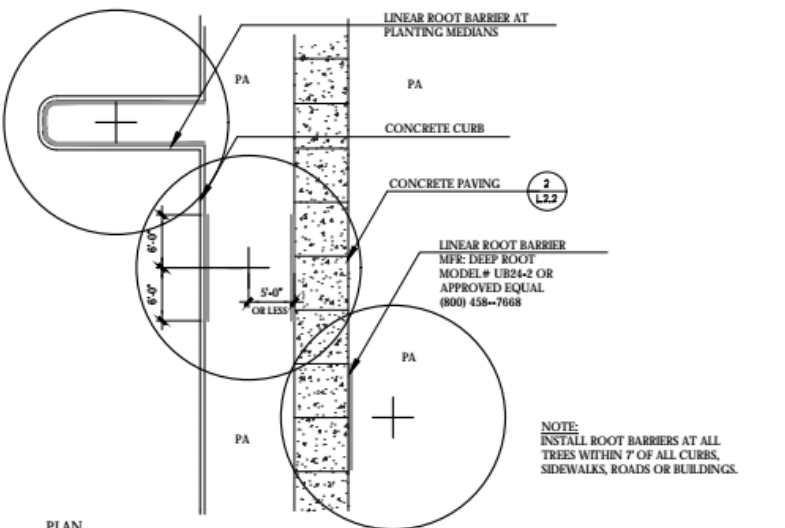

**5 LINEAR ROOT BARRIER**  
 SCALE: 1" = 10'-0"

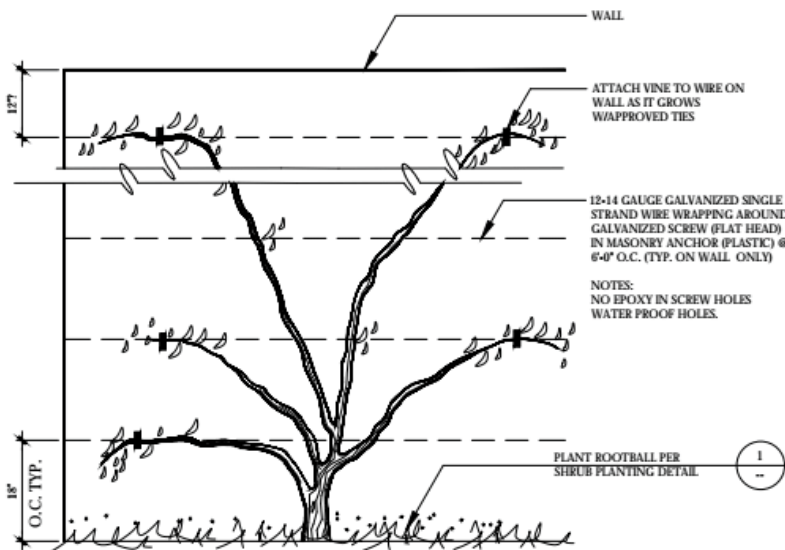

**4 VINE PLANTING**  
 SCALE: N.T.S.

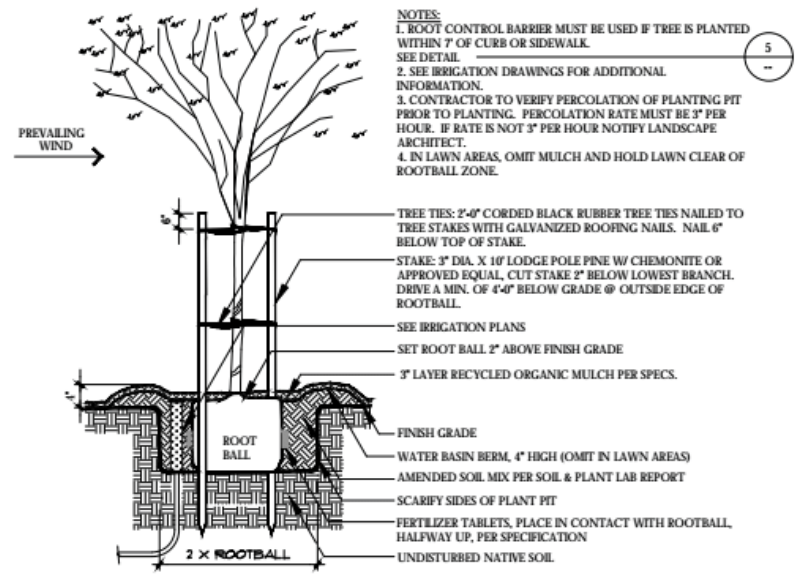

**3 TREE STAKING DETAIL - ON SITE**  
 SCALE: 3/8" = 1'-0"

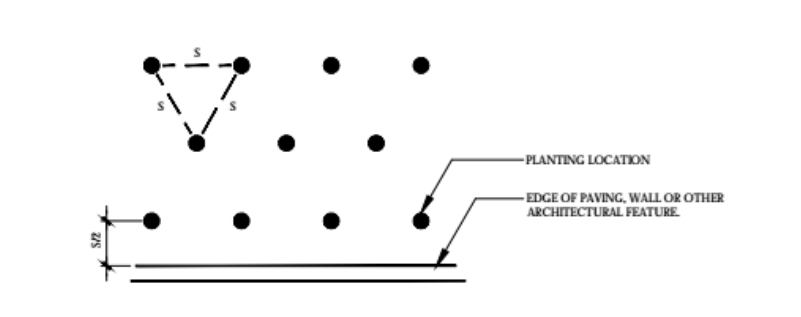

**2 PLANT SPACING**  
 SCALE: N.T.S.

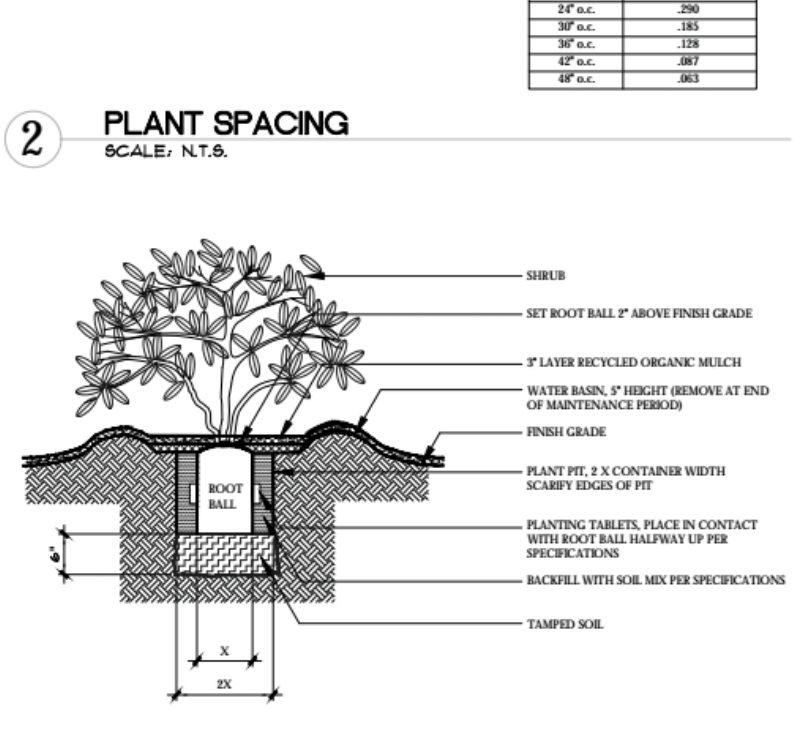

**1 SHRUB PLANTING**  
 SCALE: N.T.S.

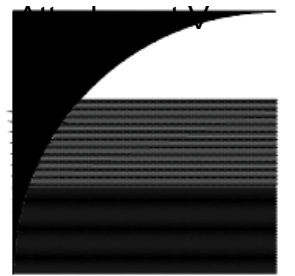

**GATES + ASSOCIATES**  
 LANDSCAPE ARCHITECTURE  
 LAND PLANNING • URBAN DESIGN  
 2671 CROW CANYON RD. SAN RAMON, CA 94583  
 T 925.776.8176 www.gates.com

**TELLES PROPERTY**

HAYWARD CALIFORNIA

ISSUE:	DESCRIPTION:	DATE:
ISSUE 1	PLAN REVIEW	04-23-18
ISSUE 2	2ND PLAN REVIEW	10-03-18
ISSUE 3	3RD PLAN REVIEW	01-19-17
ISSUE 4	4TH PLAN REVIEW	04-04-17
ISSUE 5	5TH PLAN REVIEW	06-30-17

**NOT FOR CONSTRUCTION**



PROJECT NUMBER: PROJECT #  
 DRAWN: BM  
 CHECK: MO  
 DATE: 04/04/2017  
 SCALE: VARIES



LANDSCAPE DETAILS

**L3.1-C**

DATE PLOTTED: 04/04/2017 10:01:17 AM



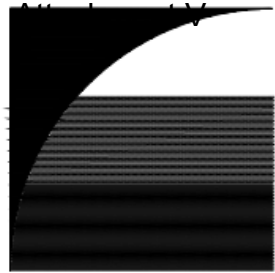

**GATES + ASSOCIATES**  
 LANDSCAPE ARCHITECTURE  
 LAND PLANNING • URBAN DESIGN  
 2671 CROW CANYON RD. SAN RAMON, CA 94583  
 T 925.736.8176 www.gates.com

**TELLES PROPERTY**

HAYWARD CALIFORNIA

ISSUE:	DESCRIPTION:	DATE:
ISSUE 1	PLAN REVIEW	04-23-18
ISSUE 2	2ND PLAN REVIEW	10-03-18
ISSUE 3	3RD PLAN REVIEW	01-19-17
ISSUE 4	4TH PLAN REVIEW	04-04-17
ISSUE 5	5TH PLAN REVIEW	06-30-17

**NOT FOR CONSTRUCTION**



PROJECT NUMBER:	PROJECT #
DRAWN:	BM
CHECK:	MO
DATE:	04/04/2017
SCALE:	VARIES



LANDSCAPE DETAILS

**L3.2-C**

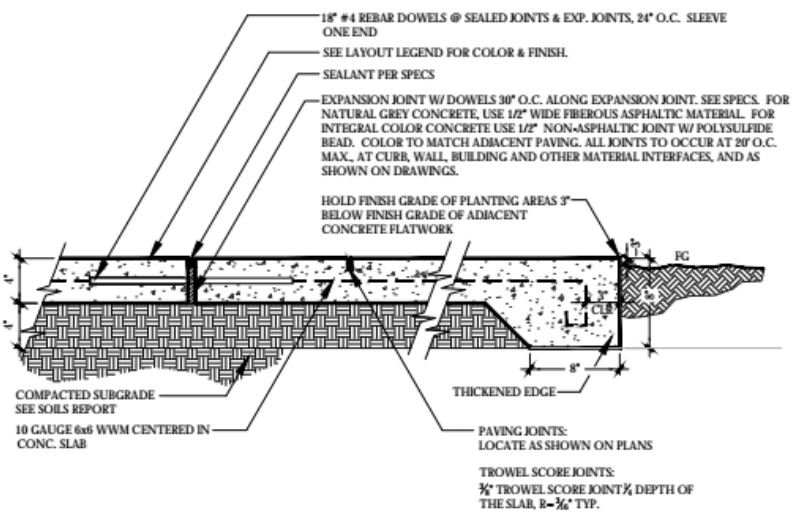
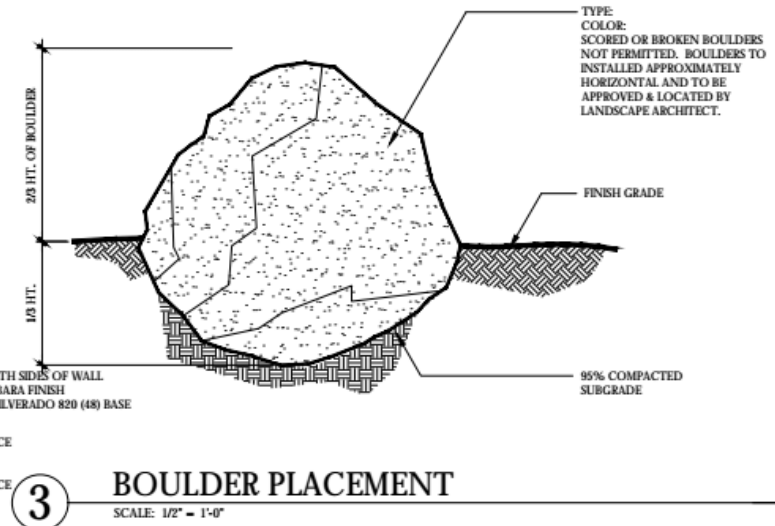

**2 PEDESTRIAN CONCRETE PAVING**  
 SCALE: 1 1/2" = 1'-0"

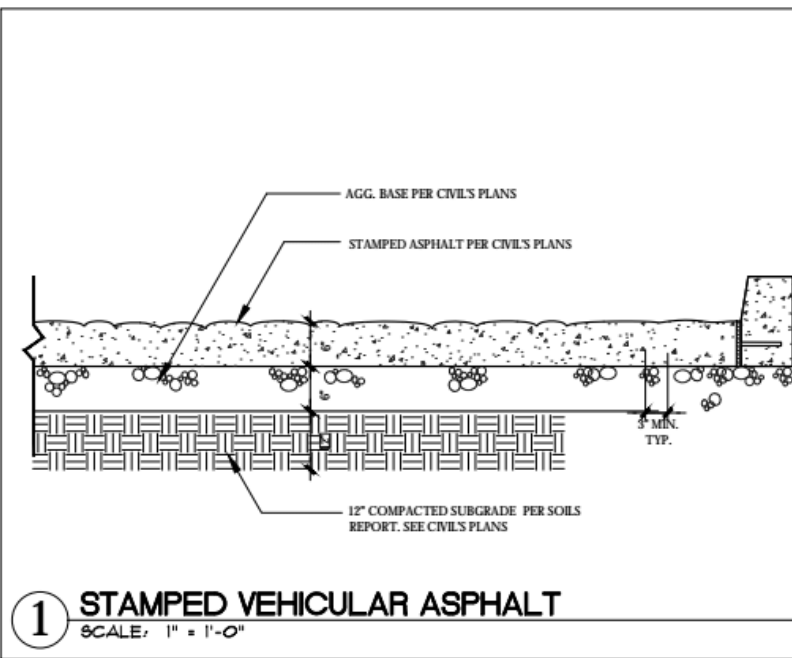

**1 STAMPED VEHICULAR ASPHALT**  
 SCALE: 1" = 1'-0"

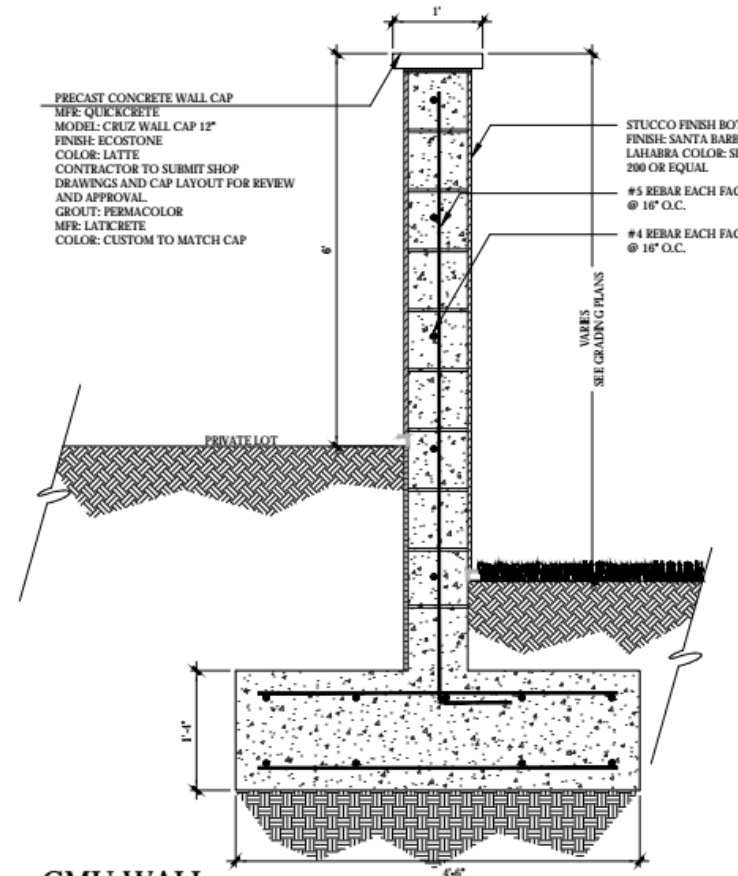

**5 CMU WALL**  
 SCALE: 1" = 1'-0"

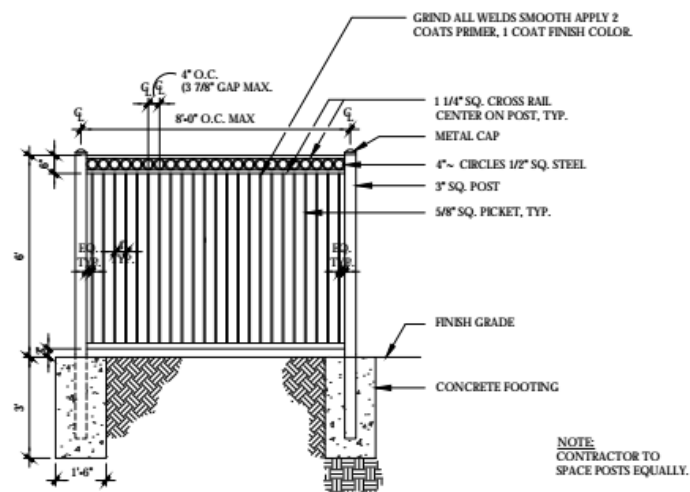

**4 6' ORNAMENTAL FENCE**  
 SCALE: 3/8" = 1'-0"

SCALE FACTOR = 12

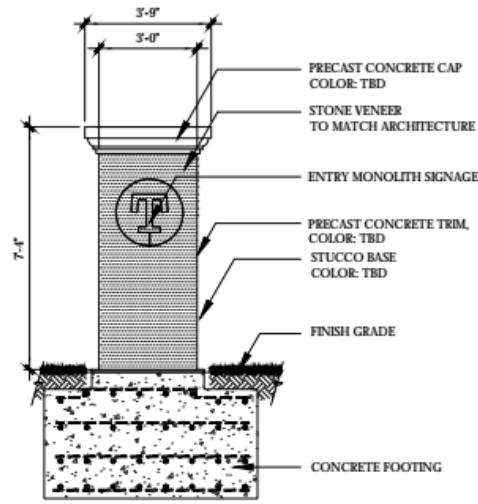

**7** DECORATIVE MONOLITH  
SCALE: 3/8" = 1'-0"

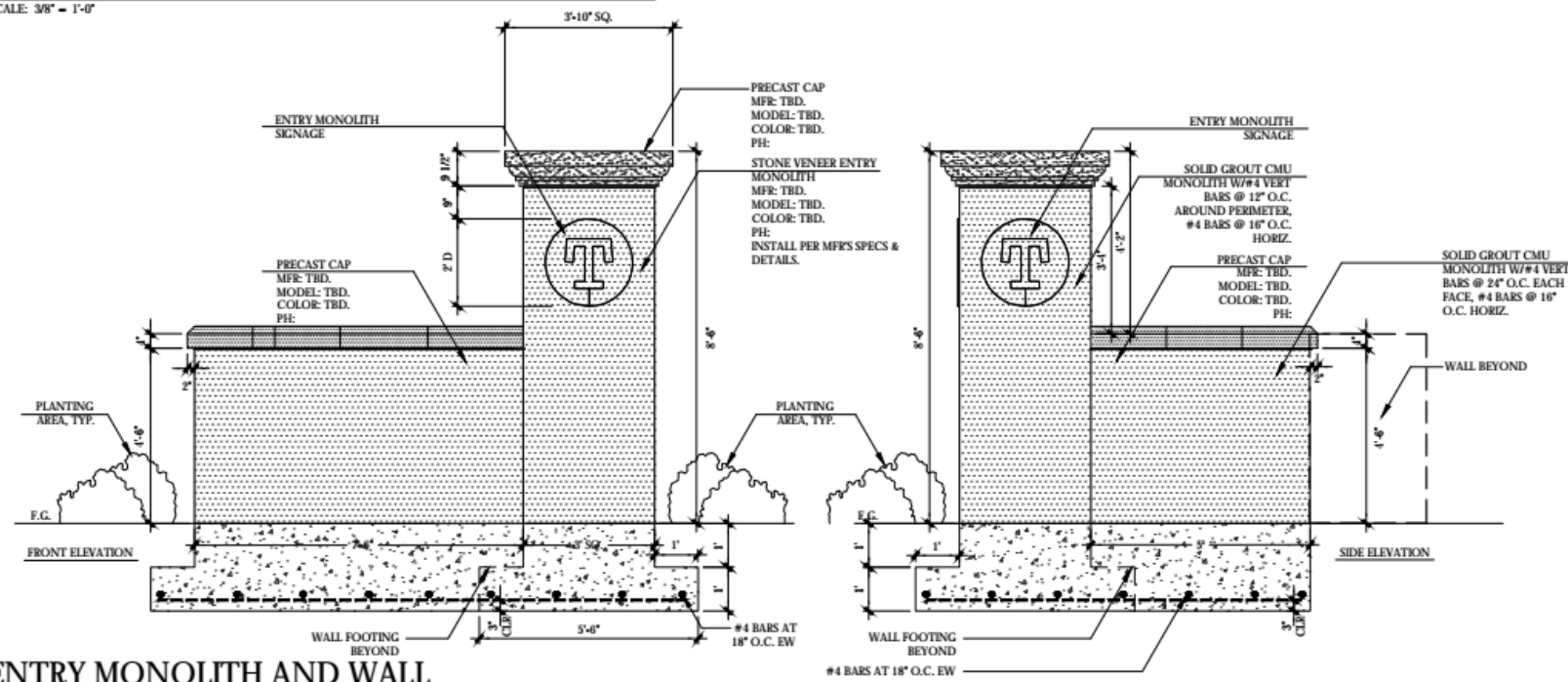

**6** ENTRY MONOLITH AND WALL  
SCALE: 1/2" = 1'-0"

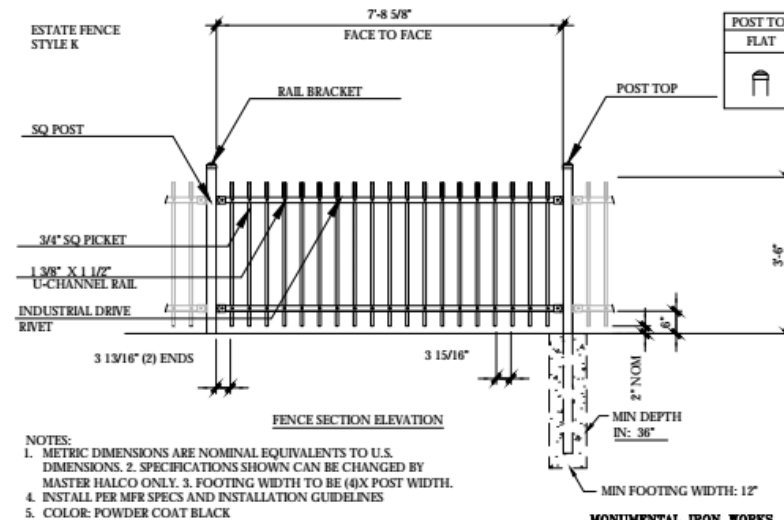

**8** FENCE AT RETENTION BASIN  
SCALE: 1/2" = 1'-0"

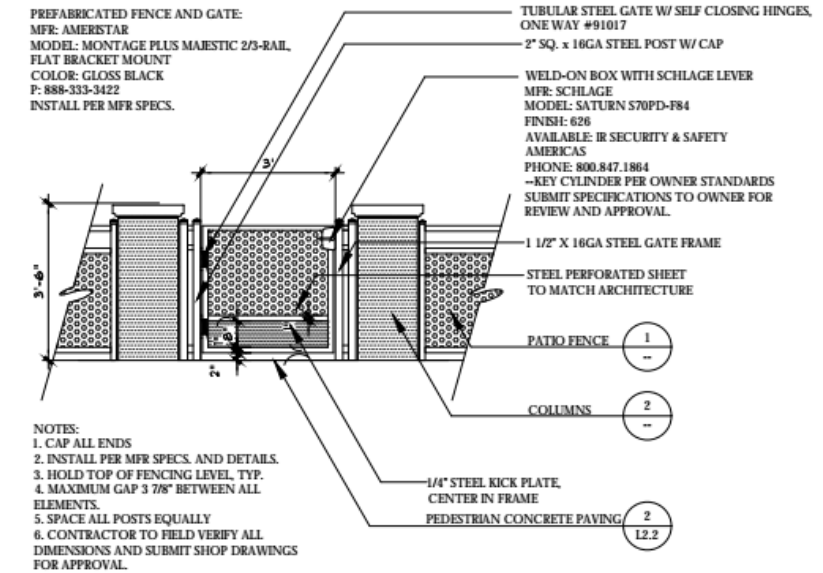

**3** 42" ORNAMENTAL METAL GATE  
SCALE: 1/2" = 1'-0"

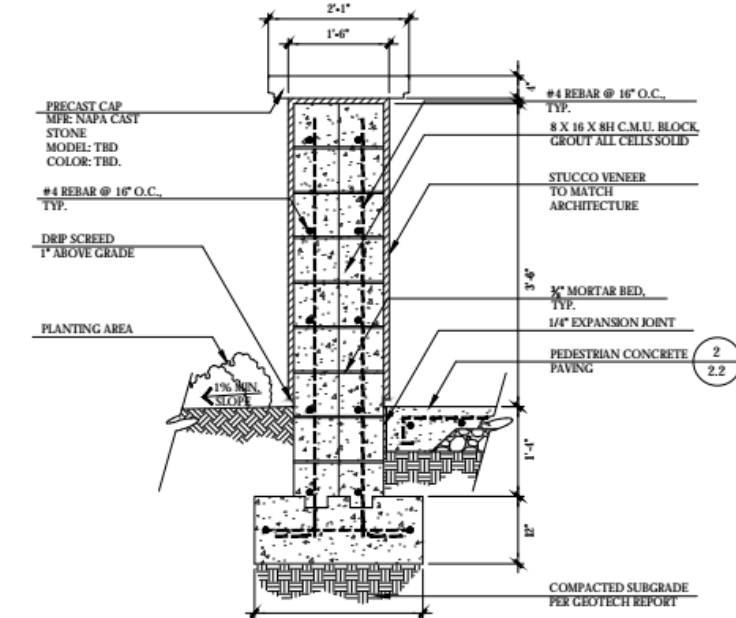

**2** COLUMN @ PATIOS SECTION  
SCALE: 3/4" = 1'-0"

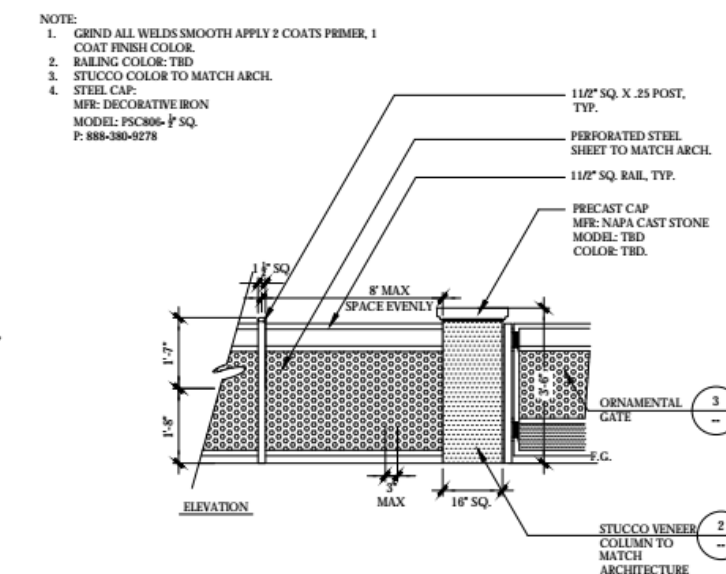

**1** PATIO WALL - ELEVATION  
SCALE: 1/2" = 1'-0"

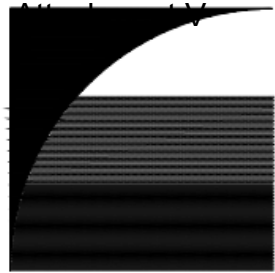

**GATES + ASSOCIATES**  
LANDSCAPE ARCHITECTURE  
LAND PLANNING • URBAN DESIGN  
2671 CROW CANYON RD. SAN RAMON, CA 94583  
T 925-776-8176 www.gates.com

**TELLES PROPERTY**

HAYWARD CALIFORNIA

ISSUE	DESCRIPTION	DATE
ISSUE 1	PLAN REVIEW	04-23-16
ISSUE 2	2ND PLAN REVIEW	10-03-16
ISSUE 3	3RD PLAN REVIEW	01-19-17
ISSUE 4	4TH PLAN REVIEW	04-04-17
ISSUE 5	5TH PLAN REVIEW	06-30-17

**NOT FOR CONSTRUCTION**



PROJECT NUMBER:	PROJECT #
DRAWN:	BM
CHECK:	MO
DATE:	04/04/2017
SCALE:	VARIABLE



LANDSCAPE DETAILS

**L3.3-C**

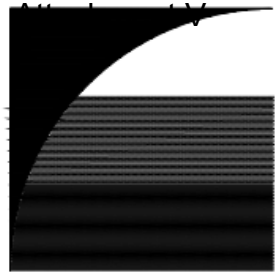

**GATES  
+ASSOCIATES**  
LANDSCAPE ARCHITECTURE  
LAND PLANNING • URBAN DESIGN  
2671 CROW CANYON RD. SAN RAMON, CA 94583  
T 925.736.8176 www.gates.com

**TELLES  
PROPERTY**

HAYWARD  
CALIFORNIA

ISSUE:	DESCRIPTION:	DATE:
ISSUE 1	PLAN REVIEW	04-23-18
ISSUE 2	2ND PLAN REVIEW	10-03-18
ISSUE 3	3RD PLAN REVIEW	01-19-17
ISSUE 4	4TH PLAN REVIEW	04-04-17
ISSUE 5	5TH PLAN REVIEW	06-30-17

**NOT FOR  
CONSTRUCTION**



PROJECT NUMBER:	PROJECT #
DRAWN:	BM
CHECK:	MO
DATE:	04/04/2017
SCALE:	VARIES



LANDSCAPE DETAILS

**L3.4-C**

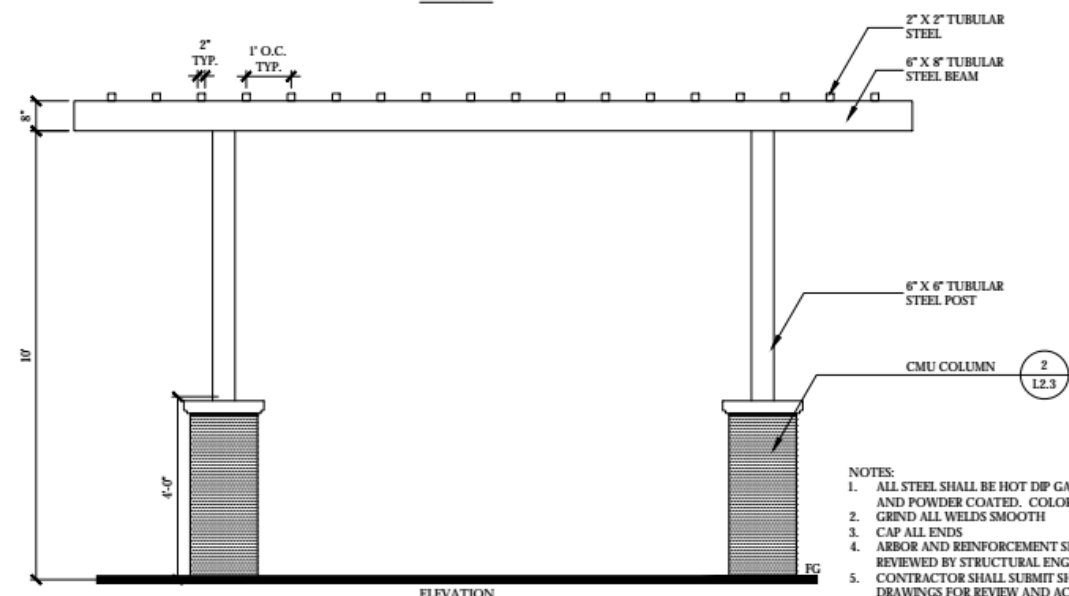
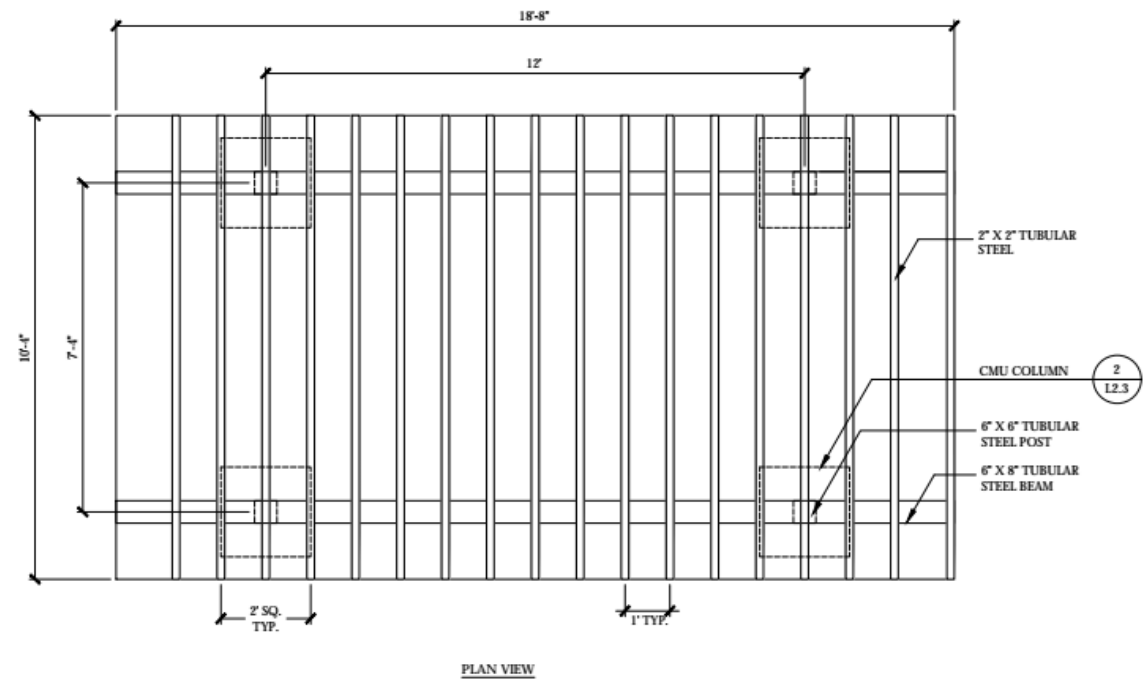

**2** 4 POST METAL ARBOR  
SCALE: 1/2" = 1'-0"

- NOTES:
1. ALL STEEL SHALL BE HOT DIP GALVANIZED AND POWDER COATED. COLOR TBD.
  2. GRIND ALL WELDS SMOOTH
  3. CAP ALL ENDS
  4. ARBOR AND REINFORCEMENT SHALL BE REVIEWED BY STRUCTURAL ENGINEER.
  5. CONTRACTOR SHALL SUBMIT SHOP DRAWINGS FOR REVIEW AND ACCEPTANCE

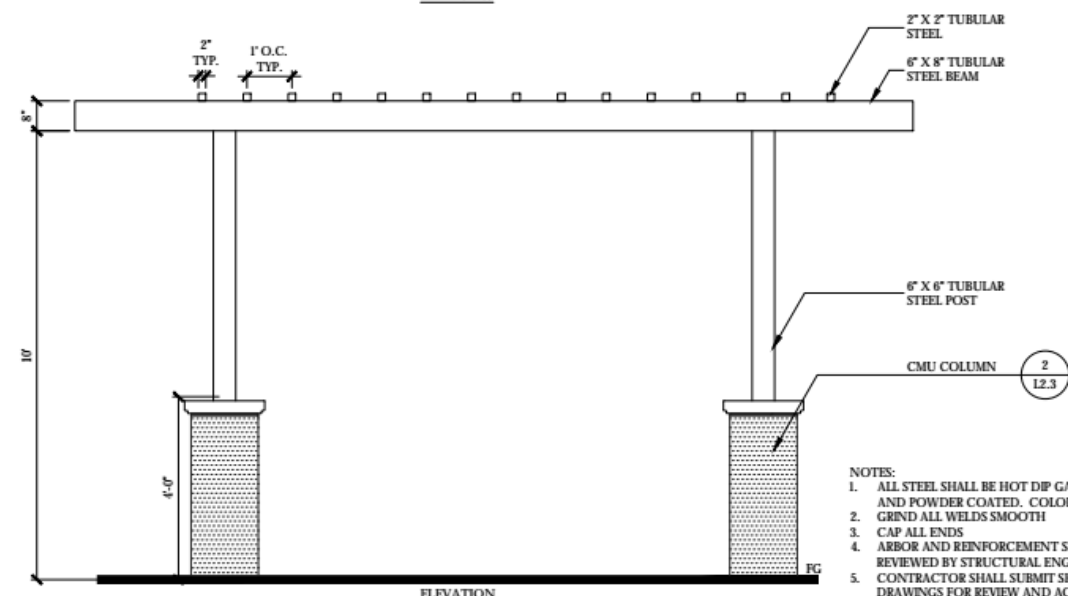
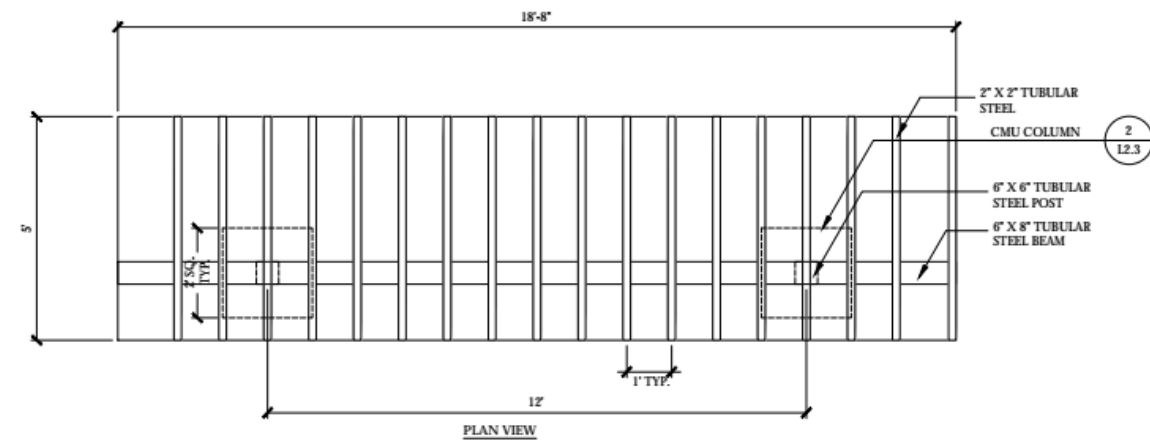

**1** 2 POST METAL ARBOR  
SCALE: 1/2" = 1'-0"

- NOTES:
1. ALL STEEL SHALL BE HOT DIP GALVANIZED AND POWDER COATED. COLOR TBD.
  2. GRIND ALL WELDS SMOOTH
  3. CAP ALL ENDS
  4. ARBOR AND REINFORCEMENT SHALL BE REVIEWED BY STRUCTURAL ENGINEER.
  5. CONTRACTOR SHALL SUBMIT SHOP DRAWINGS FOR REVIEW AND ACCEPTANCE

# WATER EFFICIENT LANDSCAPE STATEMENT

THE IRRIGATION SYSTEM SHALL BE DESIGNED TO MEET CURRENT HAYWARD WATER EFFICIENCY LANDSCAPE ORDINANCE REGULATIONS WHILE ACHIEVING THE GOAL OF EFFECTIVELY AND EFFICIENTLY PROVIDING THE LANDSCAPE WITH WATER BY MEANS OF HIGH EFFICIENCY SPRAY IRRIGATION TO THE TURF AND GROUND COVER AREAS AND DRIP IRRIGATION BUBBLERS TO RESTRICTED SHRUB PLANTING AND SHRUB MASS PLANTING AREAS AS APPLICABLE.

A WATER EFFICIENT LANDSCAPE WORKSHEET SHALL BE INCLUDED WITH HYDROZONE INFORMATION TABLE, WATER BUDGET CALCULATIONS AND IRRIGATION OPERATION SCHEDULES. THE EVAPOTRANSPIRATION FACTOR (ETAP) SHALL NOT EXCEED 0.65.

TREE BUBBLERS SHALL BE INCLUDED ON SEPARATE CIRCUITS TO ISOLATE THE IRRIGATION TO THE TREES AND PROVIDE DEEP WATERING TO PROMOTE A DEEPER ROOT STRUCTURE.

SPRAY IRRIGATION SYSTEMS FOR GROUND COVER AREAS GREATER THAN 8' WIDE IN ANY DIRECTION SHALL BE DESIGNED WITH COMMERCIAL SERIES SPRAY HEADS WITH HIGH EFFICIENCY NOZZLES THAT INCLUDE INTERNAL CHECK VALVES AND PRESSURE COMPENSATION DEVICES. THE HEADS SHALL BE DESIGNED IN A HEAD TO HEAD LAYOUT TO ACHIEVE AN EVEN LEVEL OF PRECIPITATION THROUGHOUT THE IRRIGATION SYSTEM. THE NOZZLES DELIVER WATER AT MINIMUM 70% EFFICIENCY WITH A LOW PRECIPITATION RATE THAT MATCHES THE INFILTRATION RATE OF THE SOIL.

THE DRIP SYSTEM WILL INCORPORATE PRESSURE COMPENSATING DRIP BUBBLERS WITH 1/4" DRIP TUBES TO EACH PLANT WHICH DELIVERS WATER AT 90% EFFICIENCY AT AN APPLICATION RATE THAT MATCHES THE SOIL TYPE.

A SEPARATE METER FOR IRRIGATION SHALL BE PROVIDED.

TREES WITH DIFFERENT WATERING REQUIREMENTS SHALL BE IRRIGATED ON SEPARATE VALVES.

BIO-TREATMENT AREA SHALL BE IRRIGATED WITH MATCHED PRECIPITATION ROTATOR TYPE, OR AS EFFICIENT OVERHEAD SPRAY IRRIGATION SYSTEM ALLOWING "CYCLE AND SOAKING" PROGRAM FUNCTION ON A SEPARATE VALVE.

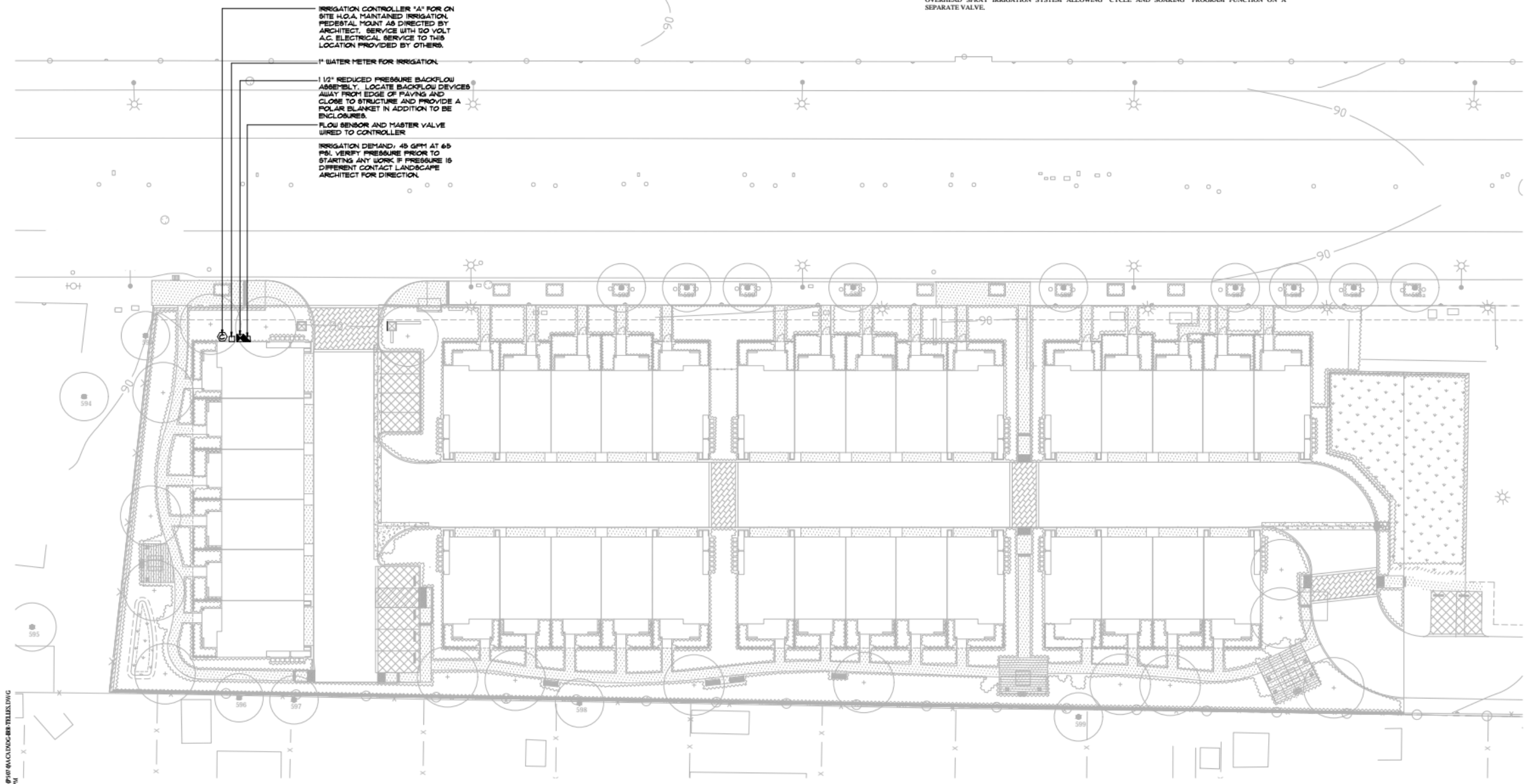

**GATES**  
**+ASSOCIATES**  
LANDSCAPE ARCHITECTURE  
LAND PLANNING • URBAN DESIGN  
2671 CROW CANYON RD. SAN RAMON, CA 94583  
T 925.736.8176 www.gates.com

**TELLES**  
**PROPERTY**  
HAYWARD  
CALIFORNIA

ISSUE	DESCRIPTION	DATE
ISSUE 1	PLAN REVIEW	04-22-16
ISSUE 2	2ND PLAN REVIEW	10-03-16
ISSUE 3	3RD PLAN REVIEW	01-19-17
ISSUE 4	4TH PLAN REVIEW	04-04-17
ISSUE 5	5TH PLAN REVIEW	06-30-17

**NOT FOR CONSTRUCTION**



PROJECT NUMBER: PROJECT #  
DRAWN: BM  
CHECK: MO  
DATE: 04/04/2017  
SCALE: 1" = 20'-0"

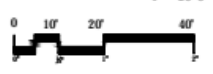

IRRIGATION PLAN

**L4.1-C**

**IRRIGATION NOTES**

- THIS DESIGN IS DIAGRAMMATIC. ALL PIPING, VALVES, ETC. SHOWN WITHIN PAVED AREAS IS FOR DESIGN CLARIFICATION ONLY AND SHALL BE INSTALLED IN PLANTING AREAS WHERE POSSIBLE. AVOID ANY CONFLICTS BETWEEN THE SPRINKLER SYSTEM, PLANTING AND ARCHITECTURAL FEATURES.
- DO NOT WILLFULLY INSTALL THE SPRINKLER SYSTEM AS SHOWN ON THE DRAWINGS WHEN IT IS OBVIOUS IN THE FIELD THAT OBSTRUCTIONS, GRADE DIFFERENCES OR DIFFERENCES IN THE AREA DIMENSIONS EXIST THAT MIGHT NOT HAVE BEEN CONSIDERED IN THE ENGINEERING. SUCH OBSTRUCTIONS OR DIFFERENCES SHOULD BE BROUGHT TO THE ATTENTION OF THE OWNER'S ACCORDINGLY, FURNISHING SUCH FITTINGS, ETC., AS MAY BE REQUIRED TO MEET SUCH CONDITIONS. DRAWINGS ARE GENERALLY DIAGRAMMATIC AND INDICATIVE OF THE WORK TO BE INSTALLED. THEN WORK SHALL BE INSTALLED IN SUCH A MANNER AS TO AVOID CONFLICTS BETWEEN IRRIGATION SYSTEMS, PLANTING, AND ARCHITECTURAL FEATURES.
- IT IS THE RESPONSIBILITY OF THE IRRIGATION CONTRACTOR TO FAMILIARIZE HIMSELF WITH ALL GRADE DIFFERENCES, LOCATION OF WALLS, RETAINING WALLS, ETC. HE SHALL COORDINATE HIS WORK WITH THE GENERAL CONTRACTOR AND OTHER SUBCONTRACTORS FOR THE LOCATION AND THE INSTALLATION OF PIPE SLEEVES THROUGH WALLS, UNDER ROADWAYS, PAVING, STRUCTURES, ETC.
- DUE TO THE SCALE OF THE DRAWINGS, IT IS NOT POSSIBLE TO INDICATE ALL OFFSETS, FITTINGS, SLEEVES, ETC., WHICH MAY BE REQUIRED. THE CONTRACTOR SHALL CAREFULLY INVESTIGATE THE STRUCTURAL AND FINISHED CONDITIONS AFFECTING ALL OF HIS WORK AND PLAN HIS WORK ACCORDINGLY, FURNISHING SUCH FITTINGS, ETC., AS MAY BE REQUIRED TO MEET SUCH CONDITIONS. DRAWINGS ARE GENERALLY DIAGRAMMATIC AND INDICATIVE OF THE WORK TO BE INSTALLED. THEN WORK SHALL BE INSTALLED IN SUCH A MANNER AS TO AVOID CONFLICTS BETWEEN IRRIGATION SYSTEMS, PLANTING, AND ARCHITECTURAL FEATURES.
- ELECTRICAL CONTRACTOR TO SUPPLY 120 VOLT A.C. (2.5 AMP) SERVICE TO CONTROLLER LOCATION. IRRIGATION CONTRACTOR TO MAKE FINAL CONNECTION FROM ELECTRICAL STUB-OUT TO CONTROLLER.
- EACH CONTROLLER SHALL HAVE ITS OWN INDEPENDENT GROUND WIRE.
- VALVE LOCATIONS SHOWN ARE DIAGRAMMATIC. INSTALL IN GROUND COVER/SHRUB AREAS WHERE POSSIBLE (NOT IN LAWN AREA).
- SPLICING OF 24 VOLT WIRES WILL NOT BE PERMITTED EXCEPT IN VALVE BOXES. LEAVE A 24" COIL OF EXCESS WIRE AT EACH SPLICE AND 100 FEET ON CENTER ALONG WIRE RUN. TAPE WIRE IN BUNDLES 10 FEET ON CENTER. NO TAPING PERMITTED INSIDE SLEEVES.
- INSTALL FOUR (4) SPARE CONTROL WIRES ALONG THE ENTIRE MAIN LINE. LOOP 36" EXCESS WIRE INTO EACH SINGLE VALVE BOX AND INTO ONE VALVE BOX IN EACH GROUP OF VALVES. SPARE WIRES SHALL BE YELLOW, COMMON WIRES SHALL BE WHITE AND CONTROL WIRES SHALL BE RED.
- THE IRRIGATION CONTRACTOR SHALL FLUSH AND ADJUST ALL DRIP TUBES FOR OPTIMUM PERFORMANCE.
- NOTIFY ARCHITECT OF ANY ASPECTS OF LAYOUT WHICH WILL PROVIDE INCOMPLETE OR INSUFFICIENT WATER COVERAGE OF PLANT MATERIAL AND DO NOT PROCEED UNTIL HIS INSTRUCTIONS ARE OBTAINED.
- ALL SPRINKLER HEADS SHALL BE SET PERPENDICULAR TO FINISH GRADE OF THE AREA TO BE IRRIGATED UNLESS OTHERWISE DESIGNATED ON THE PLANS.
- INSTALL A VALCON 5000 SERIES SPRING LOADED CHECK VALVE BELOW DRIP BUBBLERS WHERE LOW HEAD DRAINAGE WILL CAUSE EROSION AND EXCESS WATER.
- INSTALL VALVE BOXES 12" FROM AND PERPENDICULAR TO WALK, CURB, BUILDING OR LANDSCAPE FEATURE. AT MULTIPLE VALVE BOX GROUPS, EACH BOX SHALL BE AN EQUAL DISTANCE FROM THE WALK, CURB, ETC. AND EACH BOX SHALL BE 12" APART. SHORT SIDE OF VALVE BOX SHALL BE PARALLEL TO WALK, CURB LAWN, ETC.
- THE SPRINKLER SYSTEM DESIGN IS BASED ON THE MINIMUM OPERATING PRESSURE SHOWN ON THE IRRIGATION DRAWINGS. THE IRRIGATION CONTRACTOR SHALL VERIFY WATER PRESSURE PRIOR TO CONSTRUCTION. REPORT ANY DIFFERENCE BETWEEN THE WATER PRESSURE INDICATED ON THE DRAWINGS AND THE ACTUAL PRESSURE READING AT THE IRRIGATION POINT OF CONNECTION TO THE OWNER'S AUTHORIZED REPRESENTATIVE.
- OPERATE IRRIGATION CONTROLLER(S) BETWEEN THE HOURS OF 10:00 PM AND 7:00 AM.
- IRRIGATION CONTRACTOR TO NOTIFY ALL LOCAL JURISDICTIONS FOR INSPECTION AND TESTING OF INSTALLED BACKFLOW PREVENTION DEVICE.
- PRIOR TO TRENCHING, CALL UNDERGROUND SERVICE ALERT, (1-800) 642-2444 FOR NORTHERN CALIFORNIA
- WHEN VERTICAL OBSTRUCTIONS (STREET LIGHTS, TREES, FIRE HYDRANTS, ETC.) INTERFERE WITH THE PATTERN OF THE DRIP TUBING LAYOUT SO AS TO PREVENT PROPER COVERAGE, THE IRRIGATION CONTRACTOR SHALL FIELD ADJUST THE DRIP SYSTEM AT THE LOCATION OF THE OBSTRUCTION SO AS TO PROVIDE PROPER COVERAGE. ALL ADJUSTMENTS SHALL BE MADE AT NO ADDITIONAL COST TO THE OWNER.

**IRRIGATION LEGEND**

SYMBOL	MODEL NUMBER	DESCRIPTION	PSI	GPM	RADIUS
	570Z-12P-PR COM-OT-15F,H,Q	TORO 12" POP-UP SPRAY HEAD WITH PRECISION SERIES NOZZLES	30	2.3, 1.15, .30	15'
	570Z-12P-PR COM-OT-FH,Q	TORO 12" POP-UP SPRAY HEAD WITH PRECISION SERIES NOZZLES	30	1.5, .75, .40,	12'
	570Z-12P-PR COM-OT-8H,Q	TORO 12" POP-UP SPRAY HEAD WITH PRECISION SERIES NOZZLES	30	.70, .35,	8'
	1401	RAINBIRD FLOOD BUBBLER	30	.25	-
	RWS-B-C-1401	TREE BUBBLERS IN TURF- ONE RAINBIRD BUBBLER IN DEEP WATERING TUBE PER TREE	30	.25	-
	OCT856	PEPCO OCTA BUBBLER-SHRUBS	30	6 GPH PER OUTLET	-
	5633	PEPCO QUADRA BUBBLER-SHRUBS	30	6 GPH PER OUTLET	-
	M64/AP100	SPEARS FLUSHING END PLUG - LOCATE AT END OF LONG DRIP LINES			
	P-220-27	TORO REMOTE CONTROL VALVE			
	T-113-K	NIBCO GATE VALVE (LINE SIZE) WITH CROSS HANDLE INSIDE ROUND VALVE BOX			
	33-DLRC	RAIN BIRD 3/4" QUICK COUPLING VALVE			
	825Y-BV-SBBC-30SS	FEBCO BACKFLOW PREVENTOR WITH STRONG BOX ENCLOSURE TO BE INSTALLED PER CITY OF HAYWARD STANDARD DETAIL #202 SHEET L3.7			
	1-1201-1151-8130 PMR-MF-30-1"	AMIAD 1" FILTER WITH 130 MESH SCREEN WITH SENNINGER 1" IN-LINE PRESSURE REDUCING VALVE (1-22 GPM)			
	FS150P 3100-1.5"	RAINBIRD FLOW SENSOR WITH SUPERIOR NORMALLY OPEN MASTER VALVE			
	ESP12LXME ESPLXMSM12 (X3) ETC-LX LXMPED RSD-BE	RAINBIRD ET BASED CONTROLLER MOUNTED INSIDE RAINBIRD METAL PEDESTAL ENCLOSURE WITH ET DATA CARD AND WIRED RAIN SENSOR. CONTROLLER IS 48 STATION CAPACITY - 12 STATION BASE CONTROLLER PLUS THREE (3) 12 STATION MODULES ADDED TO CONTROLLER.			
		IRRIGATION INSIDE DASHED OUTLINE AREA: TORO DL2000 DRIPLINE DRIP EMITTER TUBING PART NUMBER: RGP-412-10 - 1.0 GPH EMITTERS 12" ON CENTER DRIPLINE PIPE WITH TORO LOC-EZE FITTINGS (OR EQUAL) INSTALLED 4" COVER BELOW SOIL LEVEL AND 8" FROM EDGE OF SIDEWALK OR CURB. INSTALL DRIPLINE PER INSTALLATION DETAILS SHEET L-8			
		STATION NUMBER GALLONS PER MINUTE VALVE SIZE			
		MAINLINE: SCHEDULE 40 PVC PLASTIC PIPE WITH SCHEDULE 40 PVC SOLVENT WELD FITTINGS. 18" COVER.			
		LATERAL LINE: 1120-CLASS 200 PVC PLASTIC PIPE WITH SCHEDULE 40 PVC SOLVENT WELD FITTINGS. 12" COVER.			
		SLEEVE: 1120-200 PSI PVC PLASTIC PIPE W/SCHEDULE 40 PVC PLASTIC FITTINGS. 24" COVER. SIZE NOTED ON PLANS.			

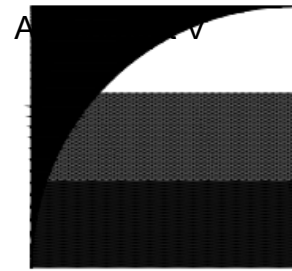

**GATES + ASSOCIATES**  
 LANDSCAPE ARCHITECTURE  
 LAND PLANNING • URBAN DESIGN  
 2671 CROW CANYON RD. SAN RAMON, CA 94583  
 T 925.736.8176 www.gates.com

**TELLES  
 PROPERTY**

HAYWARD  
 CALIFORNIA

ISSUE	DESCRIPTION	DATE
ISSUE 1	PLAN REVIEW	04-22-16
ISSUE 2	2ND PLAN REVIEW	10-03-16
ISSUE 3	3RD PLAN REVIEW	01-19-17
ISSUE 4	4TH PLAN REVIEW	04-04-17
ISSUE 5	5TH PLAN REVIEW	06-30-17

**NOT FOR  
 CONSTRUCTION**



PROJECT NUMBER: PROJECT #  
 DRAWN: BM  
 CHECK: MO  
 DATE: 04/04/2017  
 SCALE:



IRRIGATION  
 NOTES & LEGEND

**L4.2-C**

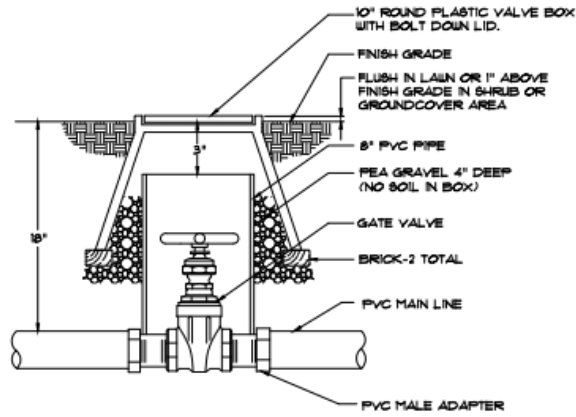

1 GATE VALVE INSTALLATION  
NTS

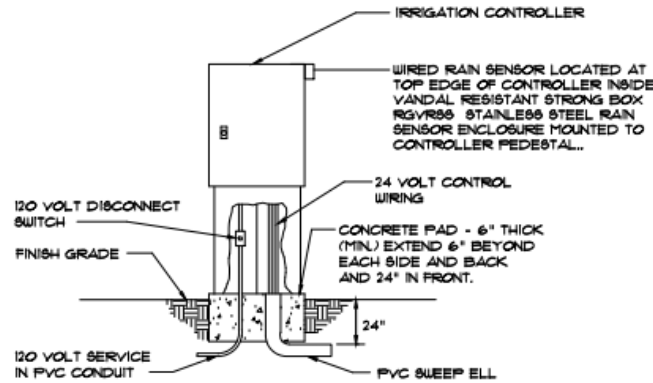

2 PEDESTAL MOUNT CONTROLLER  
NTS

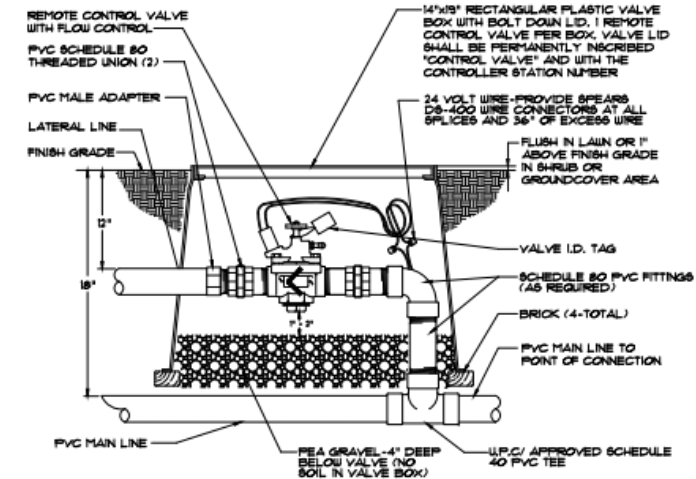

3 REMOTE CONTROL VALVE INSTALLATION  
NTS

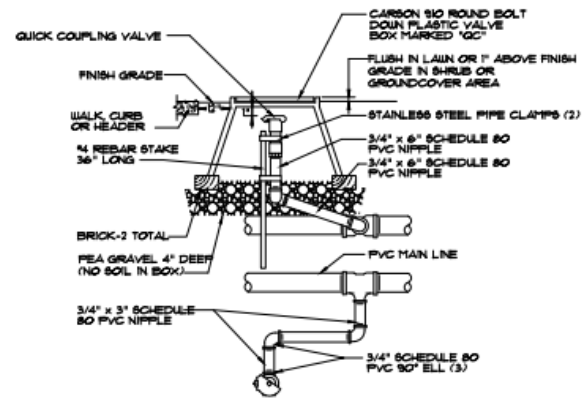

4 3/4" QUICK COUPLER IN BOX  
NTS

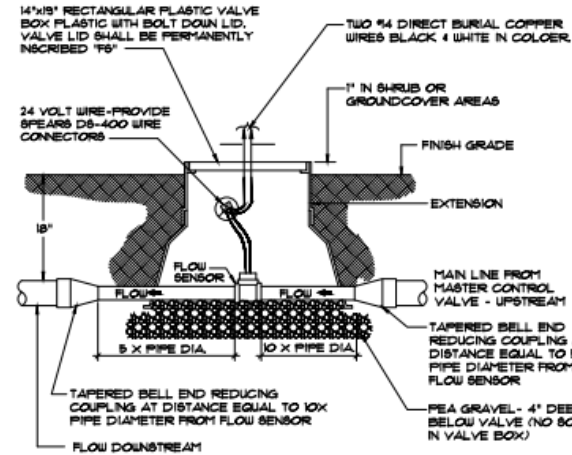

5 FLOW SENSOR INSTALLATION  
NTS

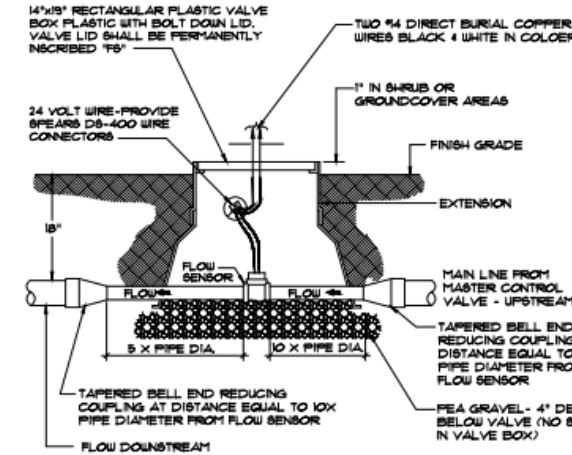

6 FLOW SENSOR INSTALLATION  
NTS

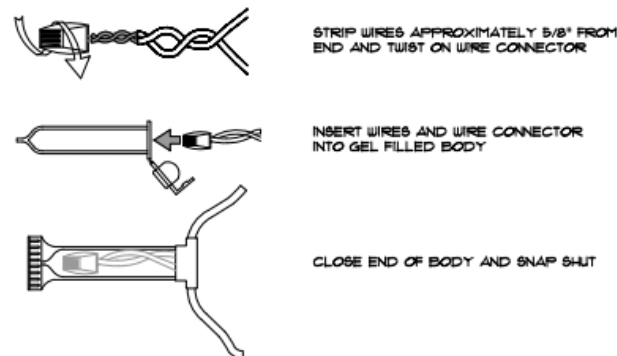

7 DBRY20 WIRE CONNECTION  
NTS

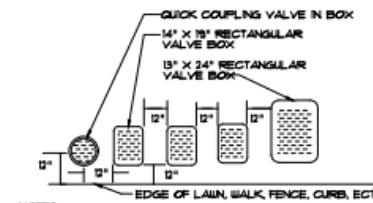

- NOTES:
- CENTER BOX OVER REMOTE CONTROL VALVE TO FACILITATE SERVICING VALVE.
  - SET BOXES 1" ABOVE FINISH GRADE IN GROUND COVER/SHRUB AREA AND FLUSH WITH FINISH GRADE IN TURF AREA.
  - SET PVC AND VALVE BOX ASSEMBLY IN GROUND COVER/SHRUB AREA WHERE POSSIBLE. INSTALL IN LAWN AREA ONLY IF GROUND COVER DOES NOT EXIST ADJACENT TO LAWN.
  - SET BOXES PARALLEL TO EACH OTHER AND PERPENDICULAR TO EDGE.
  - AVOID HEAVILY COMPACTING SOIL AROUND VALVE BOX EDGES TO PREVENT COLLAPSE AND DEFORMATION OF VALVE BOX SIDES.
  - ALL VALVE BOXES SHALL HAVE BOLT DOWN LIDS.
  - VALVE LID SHALL BE PERMANENTLY INSCRIBED 'CONTROL VALVE' AND WITH THE CONTROLLER STATION NUMBER.

8 VALVE BOX INSTALLATION  
NTS

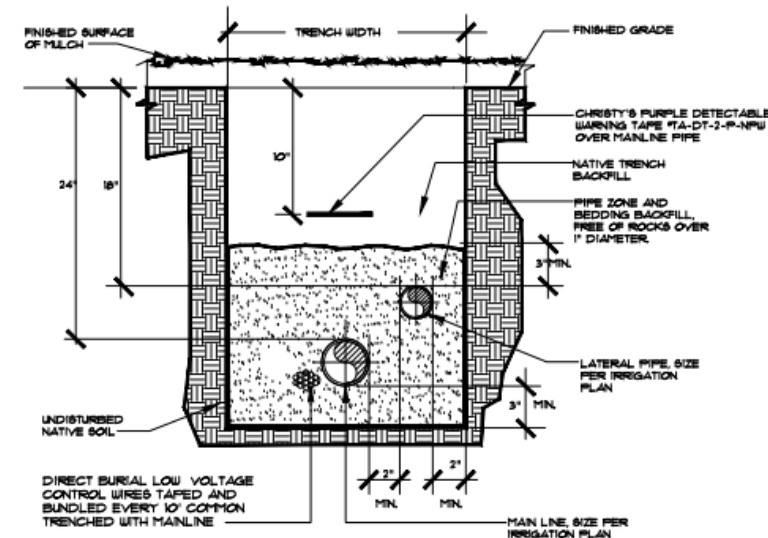

9 TYPICAL COMBINATION TRENCH  
NTS

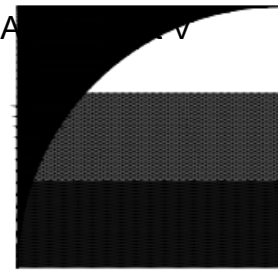

**GATES + ASSOCIATES**  
LANDSCAPE ARCHITECTURE  
LAND PLANNING • URBAN DESIGN  
2671 CROW CANYON RD. SAN RAMON, CA 94583  
T 925.736.8176 www.gates.com

**TELLES PROPERTY**

HAYWARD CALIFORNIA

ISSUE	DESCRIPTION	DATE
ISSUE 1	PLAN REVIEW	04-22-16
ISSUE 2	2ND PLAN REVIEW	10-03-16
ISSUE 3	3RD PLAN REVIEW	01-19-17
ISSUE 4	4TH PLAN REVIEW	04-04-17
ISSUE 5	5TH PLAN REVIEW	06-30-17

**NOT FOR CONSTRUCTION**



PROJECT NUMBER: PROJECT #  
DRAWN: BM  
CHECK: MO  
DATE: 04/04/2017  
SCALE:



IRRIGATION DETAILS

**L4.3-C**

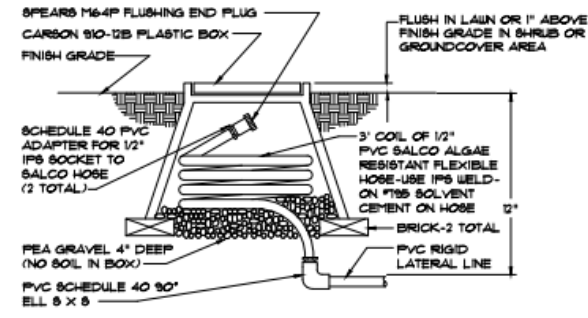

10 FLUSHING END PLUG INSTALLATION  
NTS

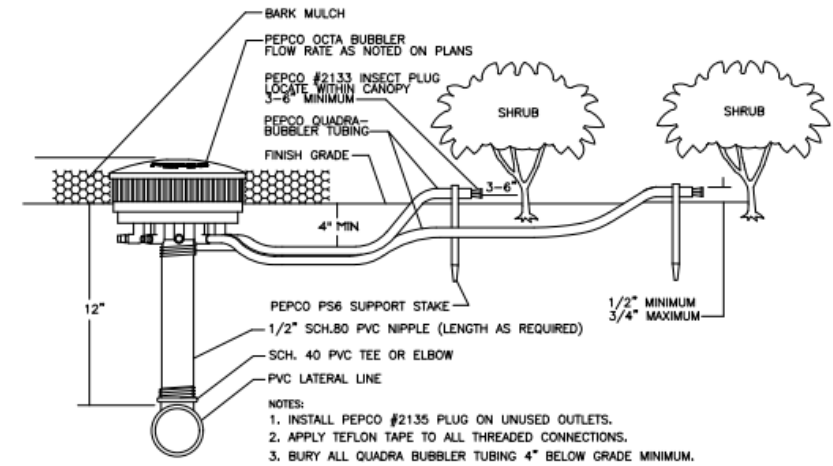

11 OCTA-BUBBLER DETAIL  
NTS

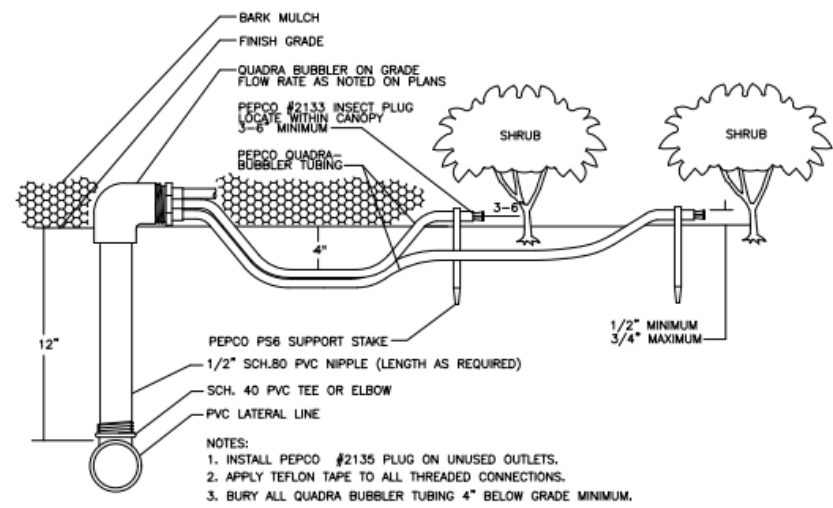

12 DRIP BUBBLER INSTALLATION  
NTS

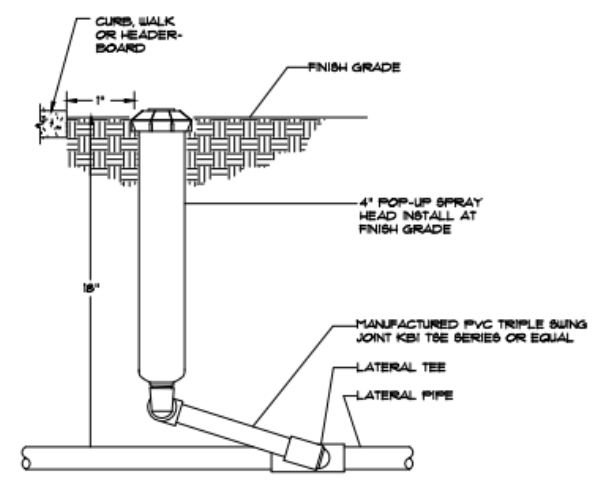

13 POP-UP 4" SPRAY HEAD INSTALLATION  
NTS

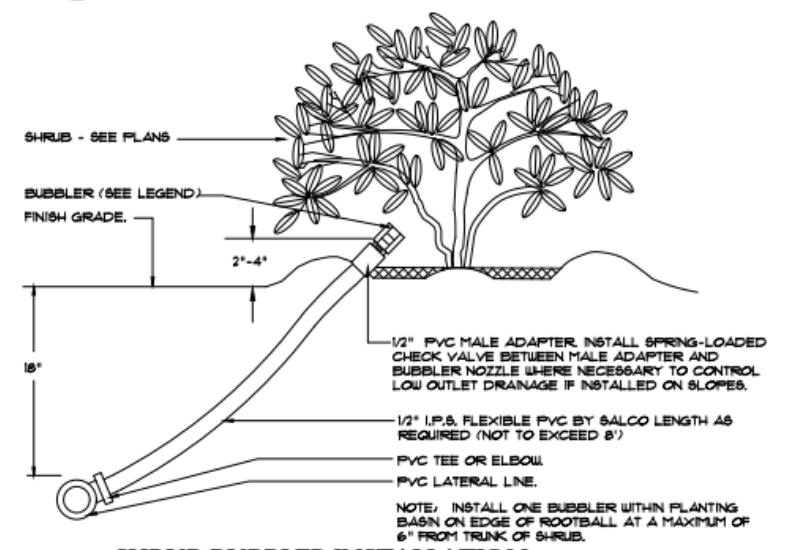

14 SHRUB BUBBLER INSTALLATION  
NTS

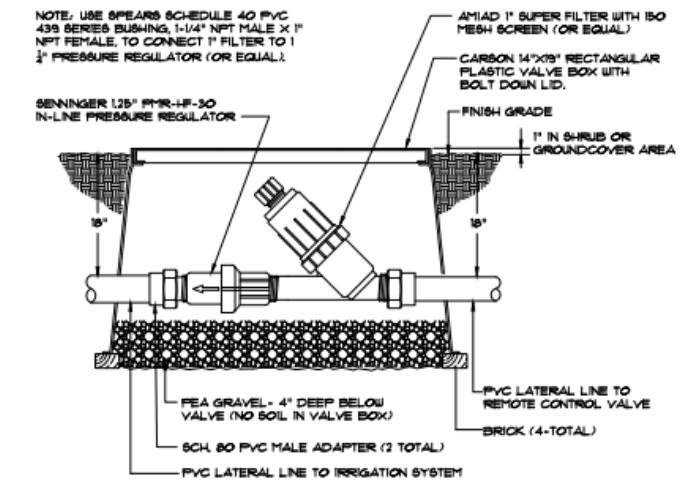

15 FILTER AND PRESSURE REGULATOR  
NTS

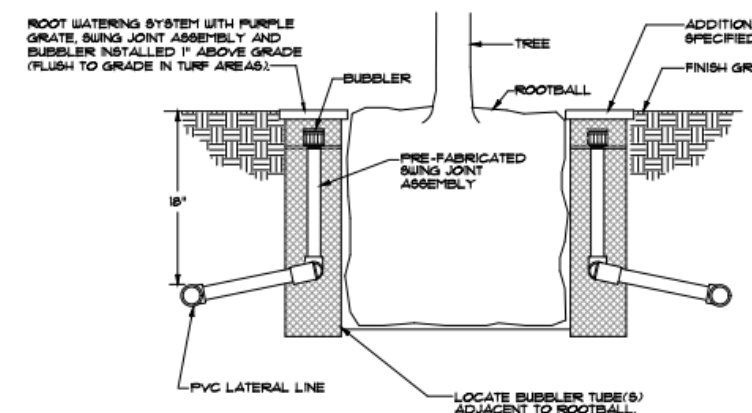

16 TREE BUBBLER INSTALLATION  
NTS

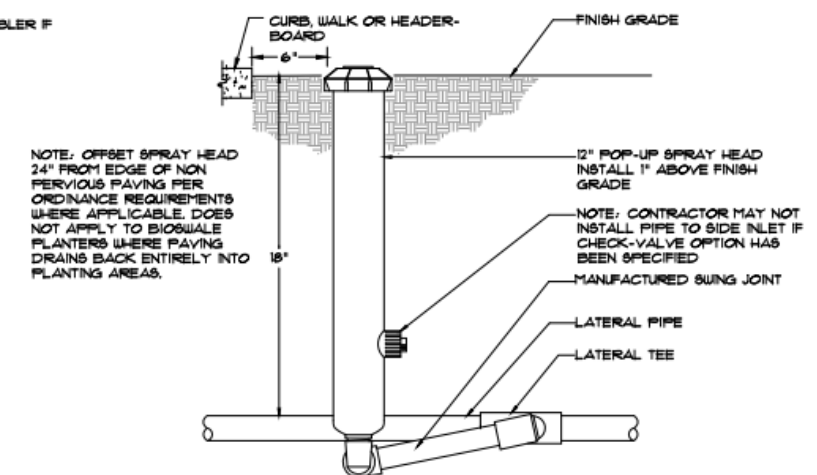

17 SPRAY HEAD INSTALLATION  
NTS

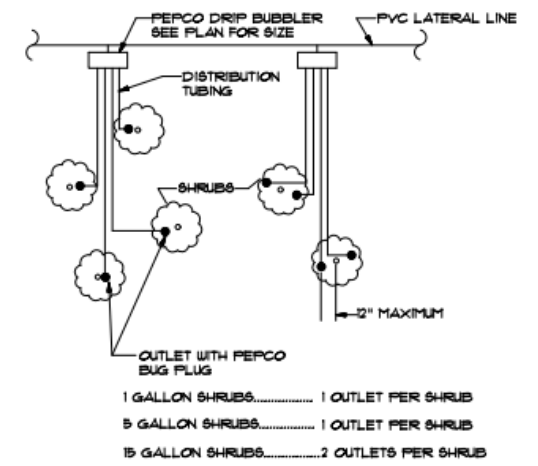

18 TYPICAL DRIP BUBBLER LAYOUT  
NTS

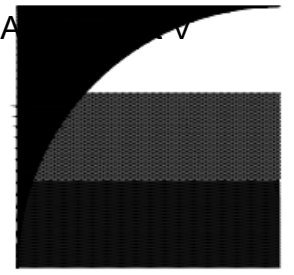

**GATES + ASSOCIATES**  
LANDSCAPE ARCHITECTURE  
LAND PLANNING • URBAN DESIGN  
2671 CROW CANYON RD. SAN RAMON, CA 94583  
T 925.736.8176 www.gates.com

**TELLES PROPERTY**

HAYWARD CALIFORNIA

ISSUE	DESCRIPTION	DATE
ISSUE 1	PLAN REVIEW	04-22-16
ISSUE 2	2ND PLAN REVIEW	10-03-16
ISSUE 3	3RD PLAN REVIEW	01-19-17
ISSUE 4	4TH PLAN REVIEW	04-04-17
ISSUE 5	5TH PLAN REVIEW	06-30-17

**NOT FOR CONSTRUCTION**



PROJECT NUMBER: PROJECT #  
DRAWN: BM  
CHECK: MO  
DATE: 04/04/2017  
SCALE:



IRRIGATION DETAILS

**L4.4-C**

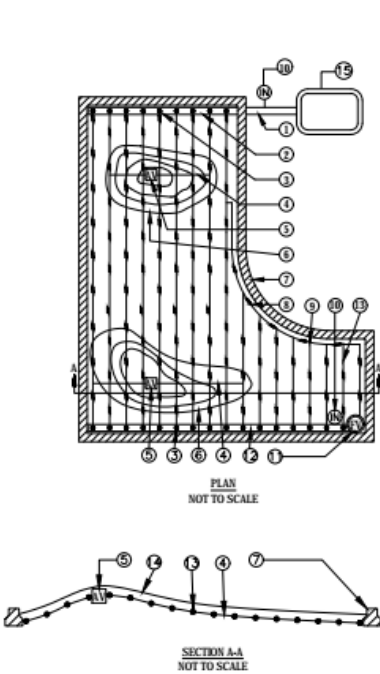

- 1 PVC LATERAL LINE FROM DRIP ZONE KIT.
- 2 PVC SUPPLY MANIFOLD.
- 3 TORO DL2000 MANIFOLD TO ELBOW CONNECTION (TYP).
- 4 AIR/VACUUM RELIEF LATERAL, TORO BLUE STRIPE POLY TUBING CENTERED ON MOUND OR BERM.
- 5 TORO DL2000 AIR/VACUUM RELIEF VALVE (YD-500-34) PLUMBED TO TORO BLUE STRIPE POLY TUBING (T-EHP1645) AT EACH HIGH POINT.
- 6 BERM (TYP).
- 7 EDGE OF PLANTER.
- 8 PERIMETER LATERALS 2" TO 4" FROM EDGE.
- 9 TORO DL2000 TEE (FTT16).
- 10 TORO T-DL-MP9 OPERATION INDICATOR CONNECTED TO LATERAL LINE INSTALLED AT THE EDGE OF THE LANDSCAPE NEAR THE CONTROL VALVE AND AT END OF DRIPLINE ZONE NEAR FLUSH VALVE.
- 11 TORO DL2000 AUTOMATIC FLUSH VALVE PLUMBED TO FLUSH MANIFOLD AT LOW POINT.
- 12 PVC FLUSH MANIFOLD.
- 13 TORO DL2000 DRIPLINE LATERAL.
- 14 FINISHED GRADE.
- 15 REMOTE CONTROL VALVE.

19 TYPICAL DRIP LAYOUT ON MOUNDS  
NTS

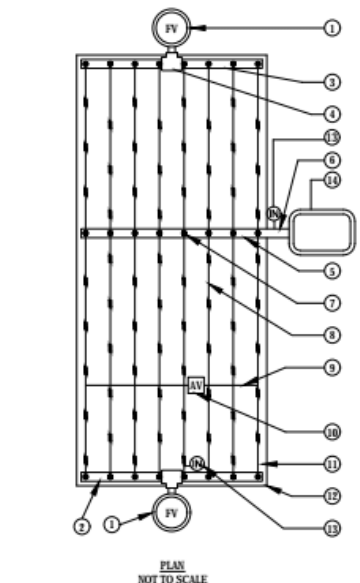

- 1 TORO DL2000 AUTOMATIC FLUSH VALVE PLUMBED TO FLUSH MANIFOLD AT LOW POINT.
- 2 MANIFOLD AT LOW POINT.
- 3 PVC FLUSH MANIFOLD.
- 4 TORO DL2000 MANIFOLD-TO-ELBOW CONNECTION (TYP).
- 5 PVC LATERAL LINE FROM DRIP ZONE KIT.
- 6 PVC SUPPLY MANIFOLD.
- 7 TORO DL2000 MANIFOLD-TO-TEE CONNECTION.
- 8 TORO DL2000 DRIPLINE LATERAL.
- 9 AIR/VACUUM RELIEF LATERAL, TORO BLUE STRIPE POLY TUBING (T-EHP1645) CENTERED ON MOUND OR BERM.
- 10 TORO DL2000 AIR/VACUUM RELIEF VALVE (YD-500-34) PLUMBED TO TORO BLUE STRIPE POLY TUBING AT EACH HIGH POINT.
- 11 PERIMETER LATERALS 2" TO 4" FROM EDGE.
- 12 AREA PERIMETER.
- 13 TORO T-DL-MP9 OPERATION INDICATOR CONNECTED TO LATERAL LINE INSTALLED AT THE EDGE OF THE LANDSCAPE NEAR THE CONTROL VALVE.
- 14 REMOTE CONTROL VALVE.

20 TYPICAL CENTER FEED DRIP SYSTEM LAYOUT  
NTS

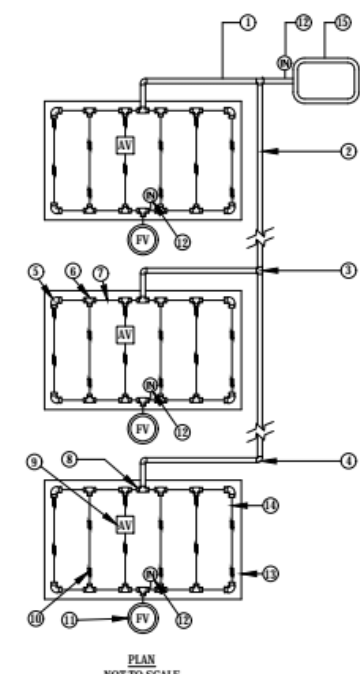

- 1 PVC LATERAL LINE FROM CONTROL VALVE.
- 2 PVC SUPPLY MANIFOLD.
- 3 PVC TEE (SxSxS).
- 4 PVC ELL (SxS).
- 5 TORO LOC-EZE ELL (FEE16).
- 6 TORO LOC-EZE TEE (FTT16).
- 7 TORO BLUE STRIPE POLY TUBING AT SUPPLY AND FLUSH END OF EACH ISLAND.
- 8 TORO LOC-EZE TEE X 1/2" SLIP ADAPTER (FTV16).
- 9 TORO DL2000 AIR/VACUUM RELIEF VALVE (YD-500-34) PLUMBED TO TUBING AT HIGH POINT.
- 10 TORO DL2000 DRIPLINE LATERAL.
- 11 TORO DL2000 AUTOMATIC FLUSH VALVE PLUMBED TO FLUSH MANIFOLD AT LOW POINT.
- 12
- 13 ISLAND PERIMETER.
- 14 PERIMETER LATERALS 2" TO 4" FROM EDGE.
- 15 CONTROL VALVE.

21 TYPICAL ISLAND MANIFOLD  
NTS

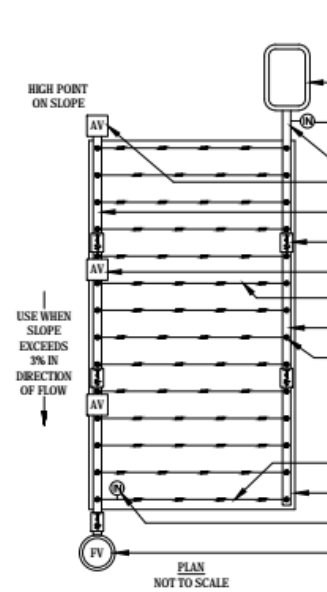

- 1 PVC LATERAL LINE FROM DRIP ZONE KIT.
- 2 TORO DL2000 AIR/VACUUM RELIEF VALVE (YD-500-34) PLUMBED TO PVC FLUSH MANIFOLD AT HIGH POINT.
- 3 PVC FLUSH MANIFOLD.
- 4 INLINE SPRING CHECK VALVE (JV0500-S2) TO HELP CONTROL LOW-HEAD DRAINAGE (TYP).
- 5 TORO DL2000 AIR/VACUUM RELIEF VALVE (YD-500-34) PLUMBED TO PVC FLUSH MANIFOLD JUST BELOW EACH CHECK VALVE (TYP).
- 6 TORO DL2000 DRIPLINE LATERAL.
- 7 PVC SUPPLY MANIFOLD.
- 8 TORO DL2000 MANIFOLD-TO-ELBOW CONNECTION (TYP).
- 9 PERIMETER LATERALS 2" TO 4" FROM EDGE.
- 10 AREA PERIMETER.
- 11 TORO T-DL-MP9 OPERATION INDICATOR CONNECTED TO LATERAL LINE INSTALLED AT THE EDGE OF THE LANDSCAPE NEAR THE CONTROL VALVE AND AT END OF DRIPLINE ZONE NEAR FLUSH VALVE.
- 12 TORO DL2000 AUTOMATIC FLUSH VALVE PLUMBED TO FLUSH MANIFOLD AT LOW POINT.
- 13 REMOTE CONTROL VALVE.

22 TYPICAL DRIP LAYOUT ON SLOPES  
NTS

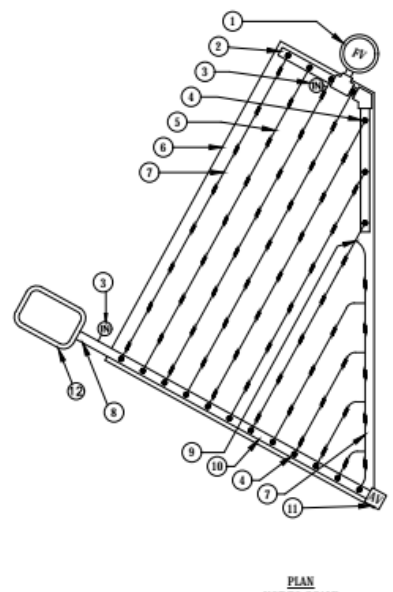

- 1 TORO DL2000 AUTOMATIC FLUSH VALVE PLUMBED TO FLUSH MANIFOLD AT LOW POINT.
- 2 PVC FLUSH MANIFOLD.
- 3 TORO T-DL-MP9 OPERATION INDICATOR CONNECTED TO LATERAL LINE INSTALLED AT THE EDGE OF THE LANDSCAPE NEAR THE CONTROL VALVE AND AT END OF DRIPLINE ZONE NEAR FLUSH VALVE.
- 4 TORO DL2000 MANIFOLD-TO-ELBOW CONNECTION (TYP).
- 5 TORO DL2000 DRIPLINE LATERAL.
- 6 AREA PERIMETER.
- 7 PERIMETER LATERALS 2" TO 4" FROM EDGE.
- 8 PVC LATERAL LINE FROM DRIP ZONE KIT.
- 9 TORO LOC-EZE TEE (FTT16).
- 10 PVC SUPPLY MANIFOLD.
- 11 TORO DL2000 AIR/VACUUM RELIEF VALVE (YD-500-34) PLUMBED TO SUPPLY MANIFOLD AT HIGH POINT.
- 12 REMOTE CONTROL VALVE.

23 TYPICAL DRIP LAYOUT ON MOUNDS  
NTS

1. ASSEMBLE AND INSTALL FILTER, REMOTES CONTROL VALVE AND PRESSURE REGULATING VALVE ASSEMBLIES ACCORDING TO DETAILS.
2. ASSEMBLE AND INSTALL SUPPLY HEADERS ACCORDING TO DETAIL. TAPE OR PLUG OPEN CONNECTIONS TO PREVENT DEBRIS CONTAMINATION.
3. ASSEMBLE AND INSTALL EXHAUST HEADERS IN ACCORDANCE WITH DETAILS. TAPE OR PLUG ALL OPEN CONNECTIONS TO PREVENT DEBRIS CONTAMINATION.
4. INSTALL DRIP LATERALS. TAPE OR PLUG OPEN ENDS WHILE INSTALLING TO PREVENT DEBRIS CONTAMINATION.
5. INSTALL AIR VACUUM RELIEF VALVES AT HIGHEST POINTS OF THE IRRIGATION ZONES IN ACCORDANCE WITH DETAILS.
6. THOROUGHLY FLUSH DRIPLINE LATERALS AND CONNECT TO EXHAUST HEADERS OR INTERCONNECTING LATERALS WHILE FLUSHING.
7. THOROUGHLY FLUSH EXHAUST HEADERS AND INSTALL LINE FLUSHING VALVES ACCORDING TO DETAILS.
8. THOROUGH FLUSHING OF EACH INSTALLATION SEGMENT IS NECESSARY TO ENSURE THAT NO DEBRIS CONTAMINATION OCCURS.
9. LOCATE AND INSTALL CHECK VALVE(S) AS NEEDED AND AS SHOWN IN INSTALLATION DETAILS.
10. SEE IRRIGATION NOTES, LEGEND/SPECIFICATIONS FOR ADDITIONAL INFORMATION.
11. ALL TREES TO BE PLANTED WITHIN CENTER OF DRIP LINE RUNS
12. BURY DRIPLINE 4" BELOW GRADE AND STAKE EACH 36" O.C. LOCATED AT EMITTER AND AS NECESSARY TO INSURE SECURITY.
13. ALL FITTINGS TO BE USED WILL BE PER MANUFACTURERS SPECIFICATION, COMPRESSION FITTINGS OR APPROVED EQUAL.
14. THE TOTAL LENGTH OF ALL INTERCONNECTED DRIP LINE SHALL NOT EXCEED THE MAXIMUM RUN LENGTH. SEE TORO SUBSURFACE IRRIGATION DESIGN GUIDE

24 SUBSURFACE DRIPLINE INSTALLATION NOTES  
NTS

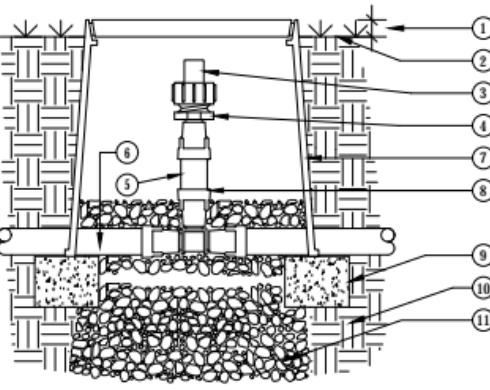

- 1 1" ABOVE FINISH GRADE.
- 2 FINISH GRADE.
- 3 TORO DL2000 FLUSH VALVE (FCH-H-FHT).
- 4 TORO LOC-EZE X 3/4" MHT ADAPTER (FJA16).
- 5 TORO BLUE STRIPE POLY TUBING.
- 6 PVC PIPING.
- 7 8" PURPLE LOCKING ROUND PLASTIC VALVE BOX, HEAT BRAND "FV" ON LID IN 1" HIGH CHARACTERS.
- 8 TORO LOC-EZE TEE (TEE16).
- 9 BRICK SUPPORTS (2 COMMON BRICKS REQUIRED).
- 10 NATIVE SOIL PER SPECIFICATIONS.
- 11 PEA GRAVEL SUMP (6" x 18").

25 FLUSH VALVE INSTALLATION  
NTS

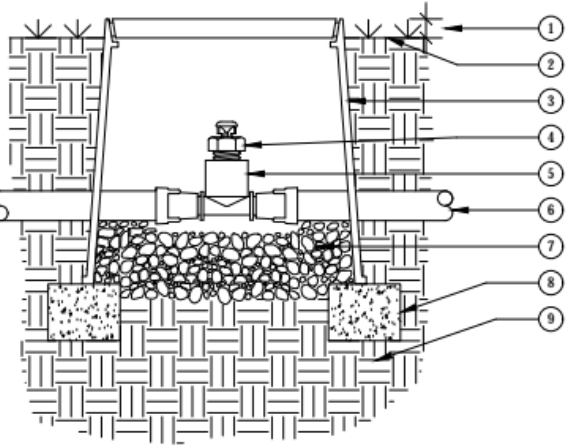

- 1 1" ABOVE FINISH GRADE.
  - 2 FINISH GRADE.
  - 3 6" ROUND PLASTIC VALVE BOX, HEAT BRAND "AR" ON LID IN 1" HIGH CHARACTERS.
  - 4 TORO DL2000 AIR/VACUUM RELIEF VALVE (YD-500-34).
  - 5 TORO LOC-EZE X 1/2" FPT TEE (FTT16).
  - 6 TORO DL2000 TUBING (RGP-XX-XXX) OR TORO BLUE STRIPE POLY TUBING (BHD1645-XXX) AIR-RELIEF LATERAL.
  - 7 PEA GRAVEL SUMP (6" DEEP).
  - 8 BRICK SUPPORTS (2 COMMON BRICKS REQUIRED).
  - 9 NATIVE SOIL PER SPECIFICATIONS.
- NOTE:  
USE ONE AIR/RELIEF VALVE FOR EVERY 7 GPM PER ZONE. LOCATE AT HIGH POINTS. REFER TO TORO PUBLICATION #ALT1111 FOR SPECIFICATIONS.

26 AIR/VACUUM RELIEF VALVE  
NTS

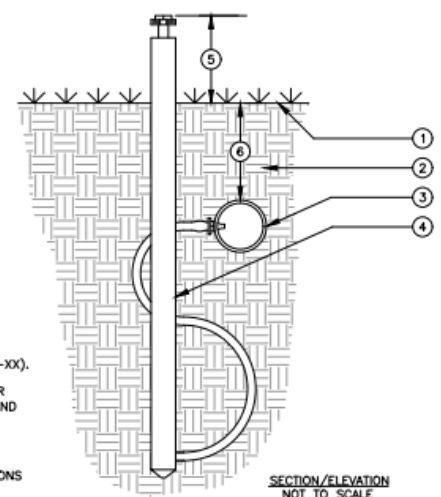

- 1 FINISH GRADE.
- 2 NATIVE SOIL BACKFILL PER SPECIFICATIONS.
- 3 TORO DL2000 DRIPLINE (RGP-XXX-XX).
- 4 TORO DL2000 OPERATION INDICATOR (DL-MP9). USE ONE PER ZONE AND LOCATED AT FLUSH END OF ZONE.
- 5 2"-3" ABOVE FINISH GRADE.
- 6 DEPTH OF TUBING PER SPECIFICATIONS (SEE TORO PUBLICATION #ALT1111).

27 TYPICAL DRIPLINE SUBGRADE INSTALLATION  
NTS

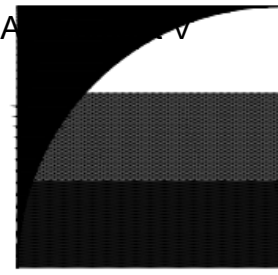

**GATES + ASSOCIATES**  
LANDSCAPE ARCHITECTURE  
LAND PLANNING • URBAN DESIGN  
2671 CROW CANYON RD. SAN RAMON, CA 94583  
T 925.736.8176 www.gates.com

**TELLES PROPERTY**

HAYWARD CALIFORNIA

ISSUE	DESCRIPTION	DATE
ISSUE 1	PLAN REVIEW	04-22-16
ISSUE 2	2ND PLAN REVIEW	10-03-16
ISSUE 3	3RD PLAN REVIEW	01-19-17
ISSUE 4	4TH PLAN REVIEW	04-04-17
ISSUE 5	5TH PLAN REVIEW	06-30-17

**NOT FOR CONSTRUCTION**



PROJECT NUMBER: PROJECT #  
DRAWN: BM  
CHECK: MO  
DATE: 04/04/2017  
SCALE:

IRRIGATION DETAILS

**L4.5-C**



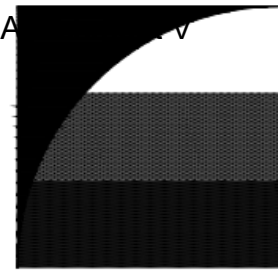

**GATES + ASSOCIATES**  
 LANDSCAPE ARCHITECTURE  
 LAND PLANNING • URBAN DESIGN  
 2671 CROW CANYON RD. SAN RAMON, CA 94583  
 T 925.736.8176 www.gates.com

**TELLES PROPERTY**

HAYWARD CALIFORNIA

ISSUE	DESCRIPTION	DATE
ISSUE 1	PLAN REVIEW	04-22-16
ISSUE 2	2ND PLAN REVIEW	10-03-16
ISSUE 3	3RD PLAN REVIEW	01-19-17
ISSUE 4	4TH PLAN REVIEW	04-04-17
ISSUE 5	5TH PLAN REVIEW	06-30-17

**NOT FOR CONSTRUCTION**



PROJECT NUMBER: PROJECT #  
 DRAWN: IM  
 CHECK: MO  
 DATE: 04/04/2017  
 SCALE:



IRRIGATION DETAILS

**L4.6-C**

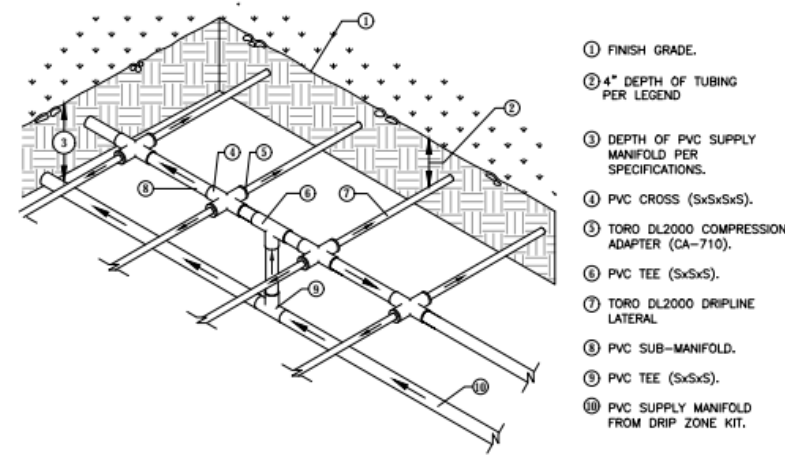

- ① FINISH GRADE.
- ② 4" DEPTH OF TUBING PER LEGEND
- ③ DEPTH OF PVC SUPPLY MANIFOLD PER SPECIFICATIONS.
- ④ PVC CROSS (SxSxT).
- ⑤ TORO DL2000 COMPRESSION ADAPTER (CA-710).
- ⑥ PVC TEE (SxSxS).
- ⑦ TORO DL2000 DRIPLINE LATERAL
- ⑧ PVC SUB-MANIFOLD.
- ⑨ PVC TEE (SxSxS).
- ⑩ PVC SUPPLY MANIFOLD FROM DRIP ZONE KIT.

28 DRIPLINE TO PVC INSTALLATION  
 NTS

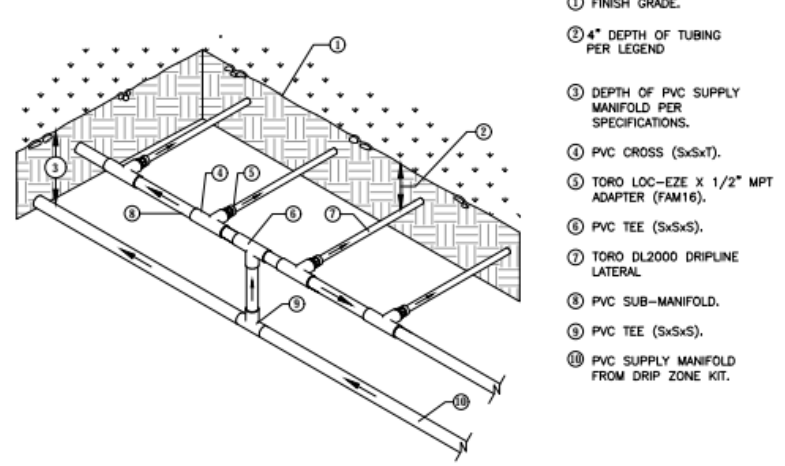

- ① FINISH GRADE.
- ② 4" DEPTH OF TUBING PER LEGEND
- ③ DEPTH OF PVC SUPPLY MANIFOLD PER SPECIFICATIONS.
- ④ PVC CROSS (SxSxT).
- ⑤ TORO LOC-EZE X 1/2" MPT ADAPTER (FAM16).
- ⑥ PVC TEE (SxSxS).
- ⑦ TORO DL2000 DRIPLINE LATERAL
- ⑧ PVC SUB-MANIFOLD.
- ⑨ PVC TEE (SxSxS).
- ⑩ PVC SUPPLY MANIFOLD FROM DRIP ZONE KIT.

29 DRIPLINE TO PVC INSTALLATION  
 NTS

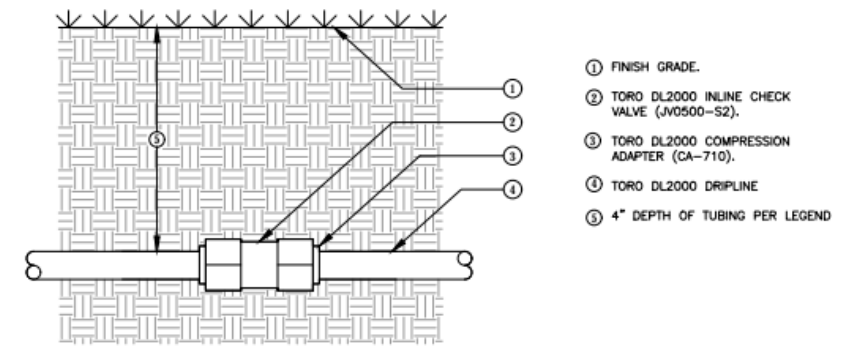

- ① FINISH GRADE.
- ② TORO DL2000 INLINE CHECK VALVE (JV0500-S2).
- ③ TORO DL2000 COMPRESSION ADAPTER (CA-710).
- ④ TORO DL2000 DRIPLINE
- ⑤ 4" DEPTH OF TUBING PER LEGEND

30 DRIPLINE TO INLINE CHECK VALVE DETAIL  
 NTS

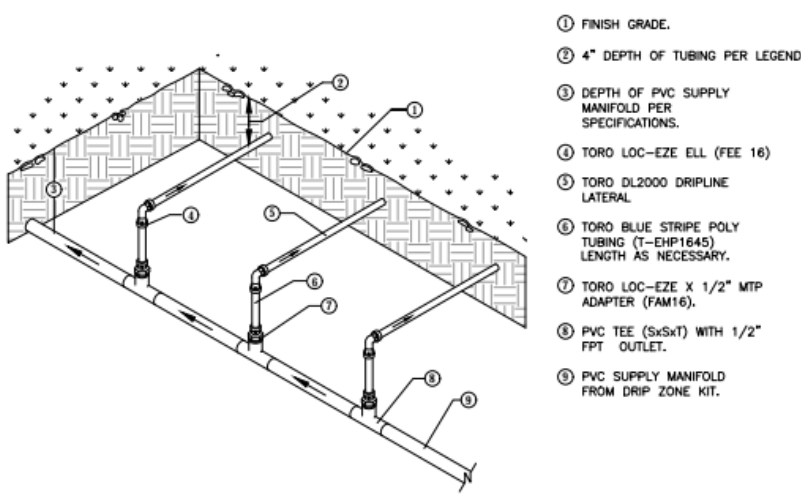

- ① FINISH GRADE.
- ② 4" DEPTH OF TUBING PER LEGEND
- ③ DEPTH OF PVC SUPPLY MANIFOLD PER SPECIFICATIONS.
- ④ TORO LOC-EZE ELL (FEE 16)
- ⑤ TORO DL2000 DRIPLINE LATERAL
- ⑥ TORO BLUE STRIPE POLY TUBING (T-EHP1645) LENGTH AS NECESSARY.
- ⑦ TORO LOC-EZE X 1/2" MPT ADAPTER (FAM16).
- ⑧ PVC TEE (SxSxT) WITH 1/2" FPT OUTLET.
- ⑨ PVC SUPPLY MANIFOLD FROM DRIP ZONE KIT.

31 DRIPLINE TO PVC HEADER INSTALLATION  
 NTS

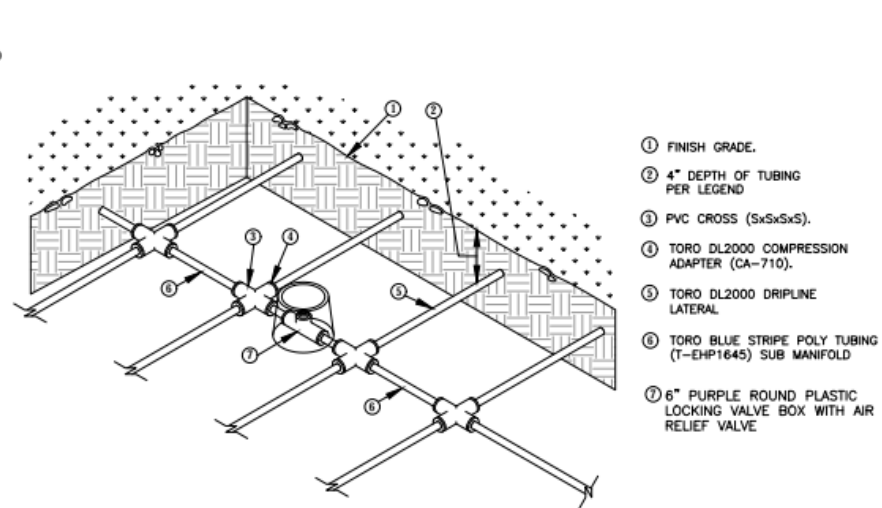

- ① FINISH GRADE.
- ② 4" DEPTH OF TUBING PER LEGEND
- ③ PVC CROSS (SxSxS).
- ④ TORO DL2000 COMPRESSION ADAPTER (CA-710).
- ⑤ TORO DL2000 DRIPLINE LATERAL
- ⑥ TORO BLUE STRIPE POLY TUBING (T-EHP1645) SUB MANIFOLD
- ⑦ 6" PURPLE ROUND PLASTIC LOCKING VALVE BOX WITH AIR RELIEF VALVE

32 AIR VACUUM RELIEF VALVE LOCATION  
 NTS

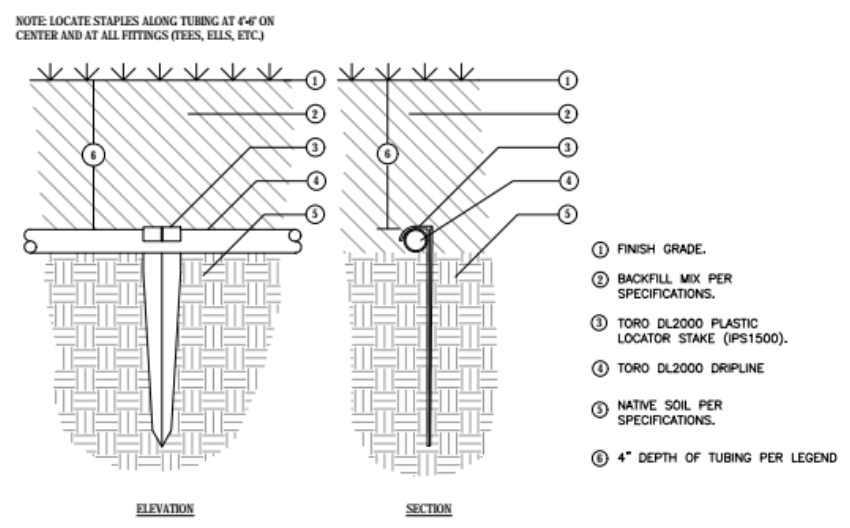

NOTE: LOCATE STAPLES ALONG TUBING AT 4" ON CENTER AND AT ALL FITTINGS (TEES, ELLS, ETC.)

- ① FINISH GRADE.
- ② BACKFILL MIX PER SPECIFICATIONS.
- ③ TORO DL2000 PLASTIC LOCATOR STAKE (IPS1500).
- ④ TORO DL2000 DRIPLINE
- ⑤ NATIVE SOIL PER SPECIFICATIONS.
- ⑥ 4" DEPTH OF TUBING PER LEGEND

33 DRIPLINE STAKE BELOW GRADE DETAIL  
 NTS

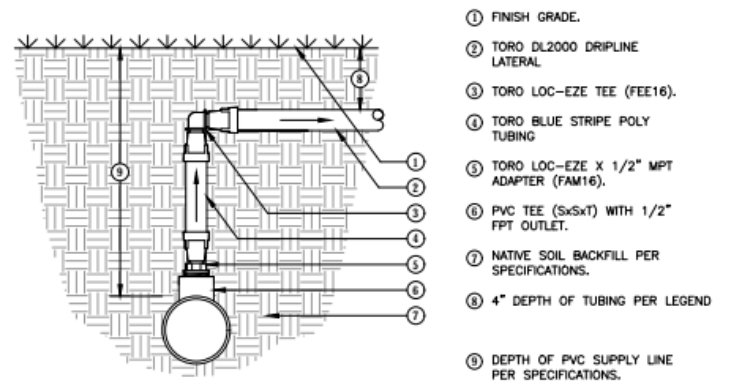

- ① FINISH GRADE.
- ② TORO DL2000 DRIPLINE LATERAL
- ③ TORO LOC-EZE TEE (FEE16).
- ④ TORO BLUE STRIPE POLY TUBING
- ⑤ TORO LOC-EZE X 1/2" MPT ADAPTER (FAM16).
- ⑥ PVC TEE (SxSxT) WITH 1/2" FPT OUTLET.
- ⑦ NATIVE SOIL BACKFILL PER SPECIFICATIONS.
- ⑧ 4" DEPTH OF TUBING PER LEGEND
- ⑨ DEPTH OF PVC SUPPLY LINE PER SPECIFICATIONS.

34 DRIPLINE TO PVC INSTALLATION  
 NTS

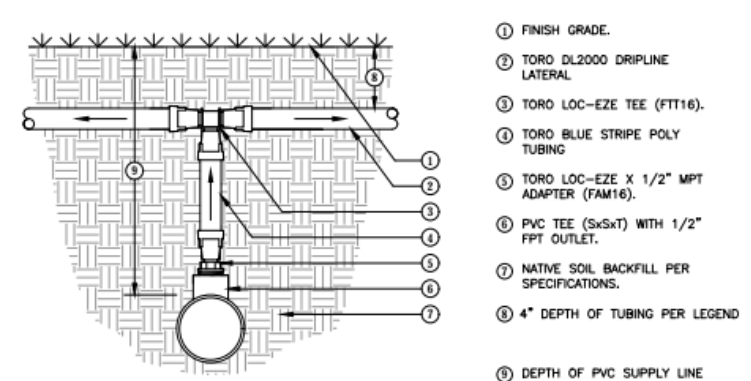

- ① FINISH GRADE.
- ② TORO DL2000 DRIPLINE LATERAL
- ③ TORO LOC-EZE TEE (FTT16).
- ④ TORO BLUE STRIPE POLY TUBING
- ⑤ TORO LOC-EZE X 1/2" MPT ADAPTER (FAM16).
- ⑥ PVC TEE (SxSxT) WITH 1/2" FPT OUTLET.
- ⑦ NATIVE SOIL BACKFILL PER SPECIFICATIONS.
- ⑧ 4" DEPTH OF TUBING PER LEGEND
- ⑨ DEPTH OF PVC SUPPLY LINE PER SPECIFICATIONS.

35 DRIPLINE TO PVC INSTALLATION  
 NTS

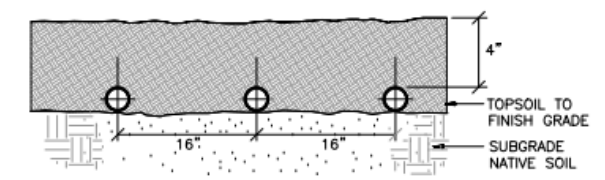

36 TYPICAL DRIPLINE SUBGRADE INSTALLATION  
 NTS

**FOR IRRIGATION AND WATER SERVICES  
WHERE REQUIRED BY CCR, TITLE 17, § 7604**

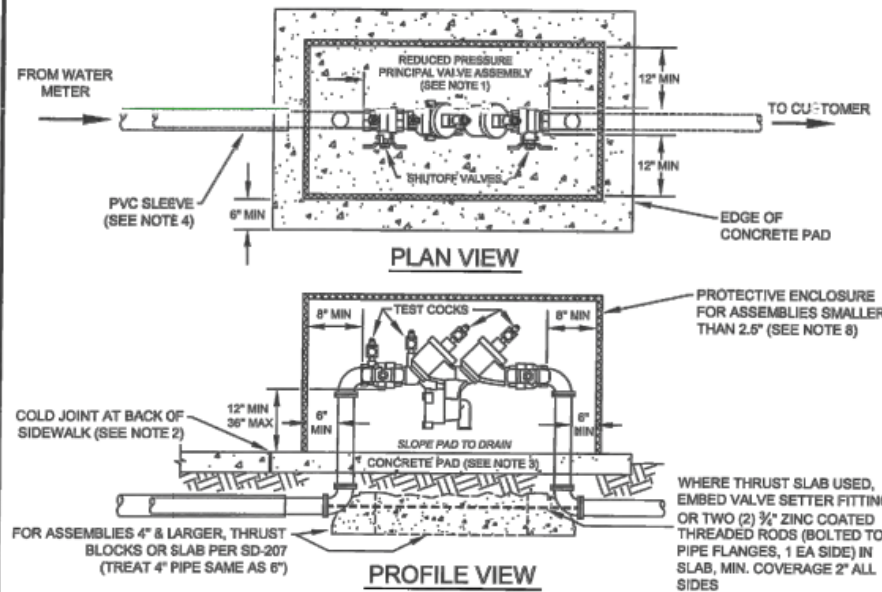

- NOTES:**
1. ALLOWED BACKFLOW ASSEMBLIES AND THEIR ORIENTATIONS SHALL BE LIMITED TO THOSE SPECIFIED ON THE "LIST OF APPROVED BACKFLOW PREVENTION ASSEMBLIES," BY THE UNIVERSITY OF SOUTHERN CALIFORNIA'S FOUNDATION FOR CROSS-CONNECTION CONTROL AND HYDRAULIC RESEARCH, 2010 OR LATEST REVISION.
  2. THE BACKFLOW DEVICE SHALL BE LOCATED: (A) A MAXIMUM OF 8' FROM BACK OF SIDEWALK (TYP.); (B) WHERE SCREENING IS REQUIRED, A MAXIMUM OF 30" FROM BACK OF SIDEWALK; OR (C) AT A LOCATION DETERMINED BY THE WATER DISTRIBUTION CROSS CONNECTION PERSONNEL IN THE FIELD.
  3. CONCRETE PAD SHALL BE CLASS B CONCRETE, 4" MINIMUM THICKNESS, REINFORCED WITH WELDED WIRE MESH.
  4. WHERE SERVICE LINES SMALLER THAN 4" PASS UNDER A SIDEWALK, THEY SHALL BE INSTALLED IN A PVC CASING/SLEEVE AT LEAST 1" LARGER THAN THE SERVICE LINE AND EXTENDS AT LEAST 6" BEYOND THE EDGES OF THE SIDEWALK.
  5. METAL PIPES EXPOSED TO SOIL OR CONCRETE SHALL BE COATED WITH 3M SCOTCHWRAP PIPE PRIMER AND WRAPPED WITH 3M SCOTCHWRAP NO. 81 BLACK PVC TAPE (3" OVERLAP).
  6. THE PORTION OF THE TRENCH FROM BACK OF METER TO THE DEVICE SHALL REMAIN OPEN UNTIL WATER DISTRIBUTION CROSS CONNECTION PERSONNEL HAVE INSPECTED AND APPROVED THE INSTALLATION.
  7. THE TESTING SIDE OF THE DEVICE SHALL HAVE A MINIMUM 24" OF CLEARANCE FROM OBSTRUCTIONS (NON-TRIMMABLE LANDSCAPING, BUILDINGS, UTILITIES, ETC.). MULTIPLE BACKFLOW DEVICES SHALL BE SEPARATED BY A MINIMUM OF 18".
  8. BACKFLOW ASSEMBLIES SMALLER THAN 2.5" SHALL BE COVERED WITH AN INSULATION BLANKET, MIN R-13, GREEN, WEATHERGUARD OR EQUAL AND PROTECTED BY A LOCKABLE WIRE CAGE ENCLOSURE FASTENED TO THE PAD. THE ENCLOSURE SHALL BE HINGED, POWDER COATED GREEN AND SECURED WITH A DOUBLE-LOCKED GALVANIZED CHAIN SUCH THAT EITHER LOCK CAN RELEASE THE CHAIN. ONE LOCK WILL BE SUPPLIED BY CITY.
  9. BACKFLOW ASSEMBLIES 2.5" AND LARGER SHALL BE SECURED BY A DOUBLE-LOCKED, GALVANIZED, STRAIGHT LINK CHAIN THAT LOCKS THE VALVE HANDWHEELS IN THE OPEN POSITION AND EITHER LOCK CAN RELEASE THE CHAIN. ONE LOCK WILL BE SUPPLIED BY CITY. IN AREAS PRONE TO VANDALISM, CITY MAY ADDITIONALLY REQUIRE A LOCKABLE PROTECTIVE ENCLOSURE (SEE NOTE 8).
  10. BOLLARDS MAY BE REQUIRED BY CITY TO PROVIDE ADDITIONAL PROTECTION (SEE SD-223 FOR BOLLARD DETAIL).
  11. BACKFLOW ASSEMBLIES INSTALLED ON POTABLE WATER SERVICES SHALL BE LEAD FREE.
  12. BACKFLOW ASSEMBLIES SHALL BE AT LEAST THE SIZE OF THE WATER METER OR THE WATER SUPPLY LINE ON THE PROPERTY SIZE OF THE METER, WHICHEVER IS LARGER.

		<b>STANDARD - REDUCED PRESSURE PRINCIPAL BACKFLOW PREVENTION ASSEMBLIES</b>		DWG. NO. <b>SD-202</b>
DRW BY: RS DATE: 11/30/12	DWG BY: AA SCALE: NTS	APPD BY: <i>[Signature]</i>	CITY ENGINEER	DR. PUBLIC WORKS
REV:    DATE:    BY:	FILED			SHT. <b>1 OF 1</b>

Water calculation worksheet for the Model Water Efficient Landscape Ordinance AB 1881

Total Landscape Area (sf)	24,730	KL	Landscape Coefficient	Eto	Referenced Evapotranspiration Rate				
Special Landscape Area (SLA)	0	Ks	Species Factor	ETAF	ET Adjustment factor				
Historical Eto for project city	44.2	Kd	Density Factor	LA	Total Landscape area				
Turf Rotor Efficiency	0.75	Kmc	Microclimate Factor	0.62	Conversion factor to gallons				
Flood bubbler Irrigation Efficiency	0.81	IE	Irrigation Efficiency	SLA	Special Landscape Area				
Spray irrigation Efficiency	0.75	MAWA = (Eto)(0.62)(0.55 x LA + 0.45 x SLA)							
Drip Irrigation Efficiency	0.81	ETWU = (Eto)(0.62) [(PFxHA / IE) + SLA]							
Stream Spray Efficiency	0.75								
<b>Maximum Applied Water Use (MAWA)</b>									
Eto	Conversion	ETAF	LA	(1-ETAF)	SLA				
44.2	0.62	0.55	24,730	0.45	0				
					Gallons per year				
Total landscape area					372,736				
<b>MAXIMUM APPLIED WATER ALLOWANCE</b>					<b>372,736</b>				
<b>Estimated Total Water Use (ETWU)</b>									
Hydrozone & Irrigation method	Area (sf)	Eto	Ks	Kd	Kmc	KL	IE	Conversion	Gallons per year
Telles	24,730	44.2	0.4	1	1	0.4	0.81	0.62	334,667
Total area									24,730
<b>TOTAL WATER APPLIED</b>									<b>334,667</b>
Difference between MAWA & ETWU									38,068
% ETWU is under MAWA									10.2%

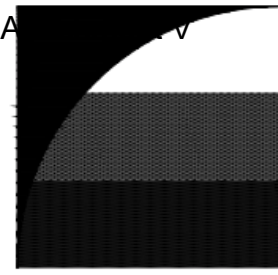

**GATES + ASSOCIATES**  
 LANDSCAPE ARCHITECTURE  
 LAND PLANNING • URBAN DESIGN  
 2671 CROW CANYON RD. SAN RAMON, CA 94583  
 T 925.736.8176 www.gates.com

**TELLES PROPERTY**

HAYWARD CALIFORNIA

ISSUE:	DESCRIPTION:	DATE:
ISSUE 1	PLAN REVIEW	04-22-16
ISSUE 2	2ND PLAN REVIEW	10-03-16
ISSUE 3	3RD PLAN REVIEW	01-19-17
ISSUE 4	4TH PLAN REVIEW	04-04-17
ISSUE 5	5TH PLAN REVIEW	06-30-17

**NOT FOR CONSTRUCTION**



PROJECT NUMBER:                      PROJECT #  
 DRAWN:                                      BM  
 CHECK:                                      MO  
 DATE:                                        04/04/2017  
 SCALE:



IRRIGATION DETAILS AND CALCS

**L4.7-C**

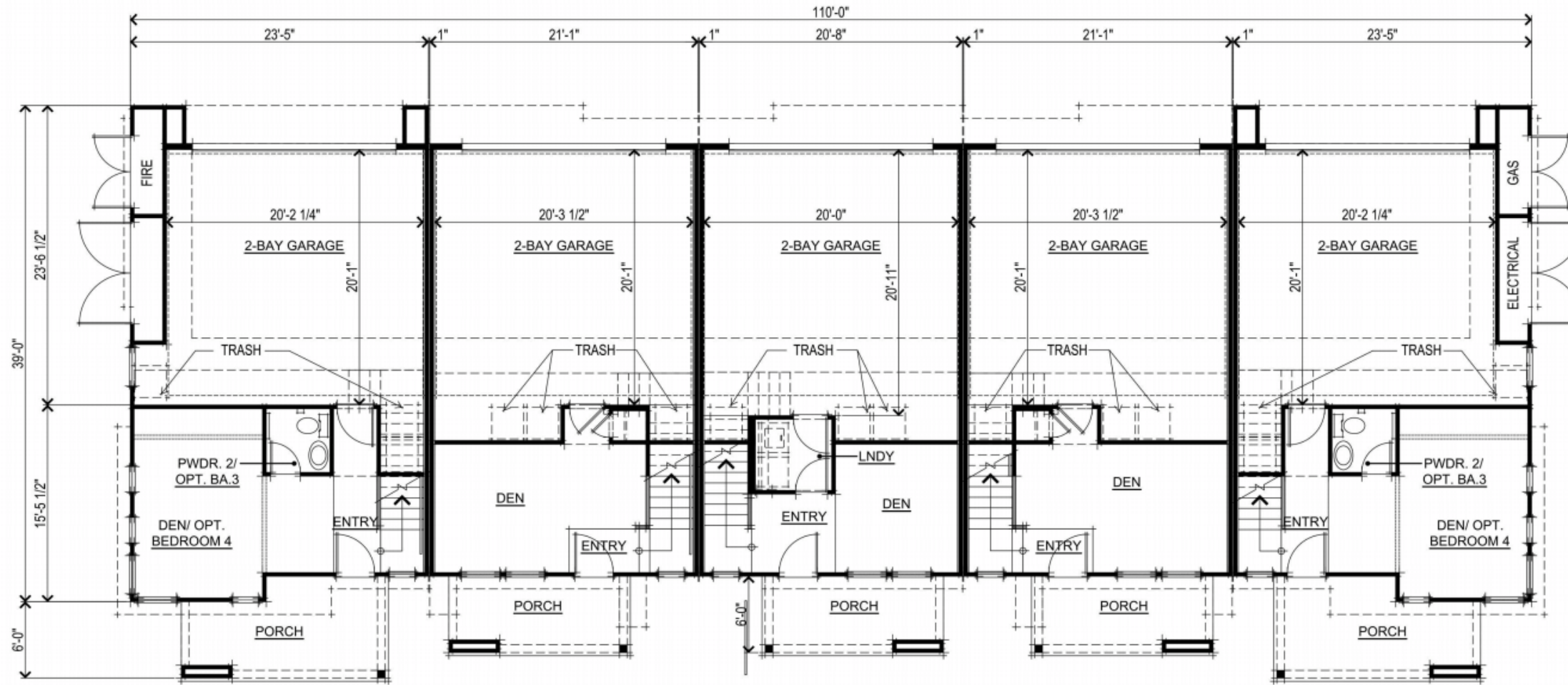

PLAN 3 REVERSE

SQUARE FOOTAGES

FIRST FLOOR	317 SQ. FT.
SECOND FLOOR	913 SQ. FT.
THIRD FLOOR	844 SQ. FT.
TOTAL LIVING	2074 SQ. FT.
2-BAY GARAGE	456 SQ. FT.

PLAN 2 REVERSE

SQUARE FOOTAGES

FIRST FLOOR	244 SQ. FT.
SECOND FLOOR	788 SQ. FT.
THIRD FLOOR	791 SQ. FT.
TOTAL LIVING	1823 SQ. FT.
2-BAY GARAGE	472 SQ. FT.

PLAN 1 REVERSE

SQUARE FOOTAGES

FIRST FLOOR	234 SQ. FT.
SECOND FLOOR	774 SQ. FT.
THIRD FLOOR	727 SQ. FT.
TOTAL LIVING	1735 SQ. FT.
2-BAY GARAGE	469 SQ. FT.

PLAN 2 STANDARD

SQUARE FOOTAGES

FIRST FLOOR	244 SQ. FT.
SECOND FLOOR	788 SQ. FT.
THIRD FLOOR	791 SQ. FT.
TOTAL LIVING	1823 SQ. FT.
2-BAY GARAGE	472 SQ. FT.

PLAN 3 STANDARD

SQUARE FOOTAGES

FIRST FLOOR	317 SQ. FT.
SECOND FLOOR	913 SQ. FT.
THIRD FLOOR	844 SQ. FT.
TOTAL LIVING	2074 SQ. FT.
2-BAY GARAGE	456 SQ. FT.

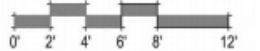

5 UNIT BUILDING FIRST FLOOR PLAN  
A.1-C

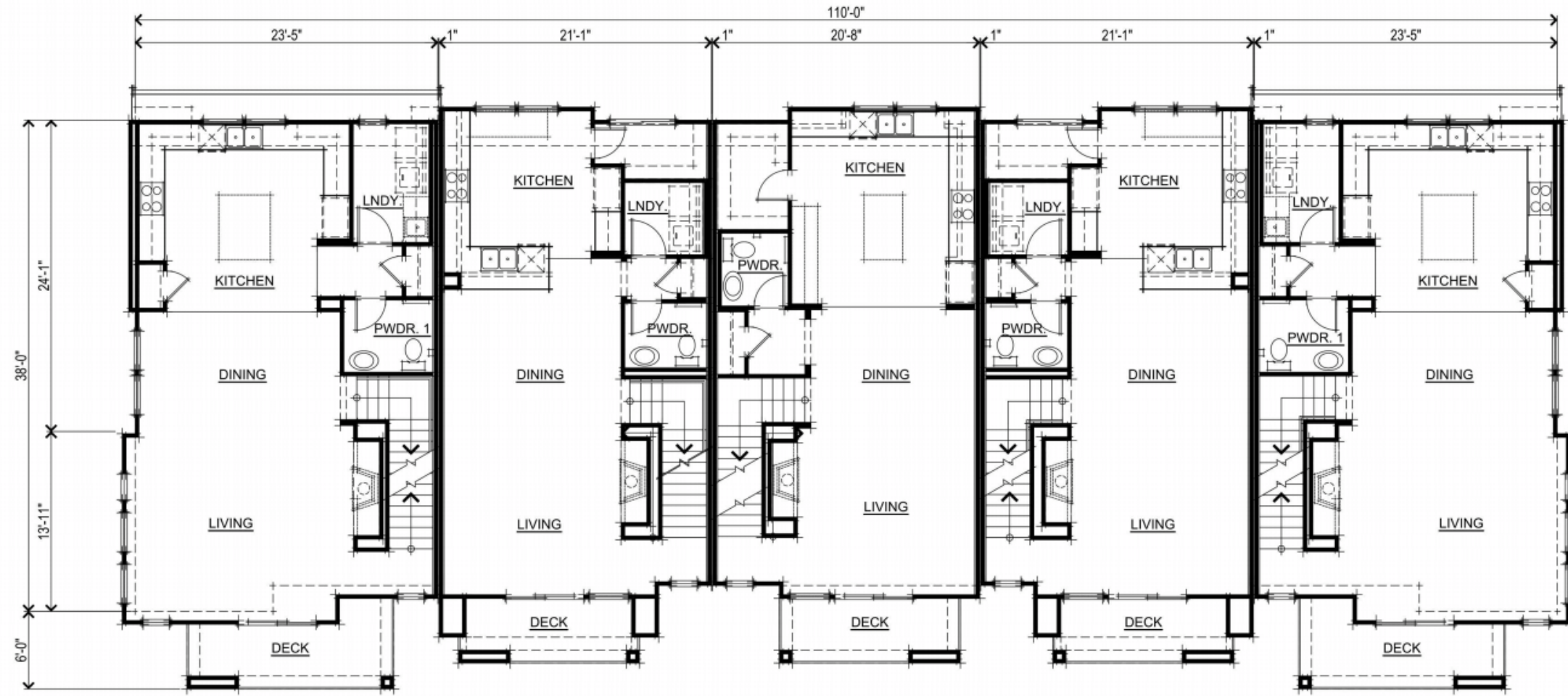

PLAN 3 REVERSE      PLAN 2 REVERSE      PLAN 1 REVERSE      PLAN 2 STANDARD      PLAN 3 STANDARD

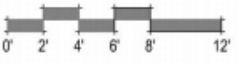

Telles Property  
Hayward, CA  
January 20, 2017

5 UNIT BUILDING SECOND FLOOR PLAN  
A.2-C

**KB Home**  
5000 Executive Parkway, Suite 125, San Ramon, CA 94583  
925.983.4500

3361 Walnut Blvd. Suite 120 Brentwood, CA 94513  
925.634.7000  
www.strausdesign.com



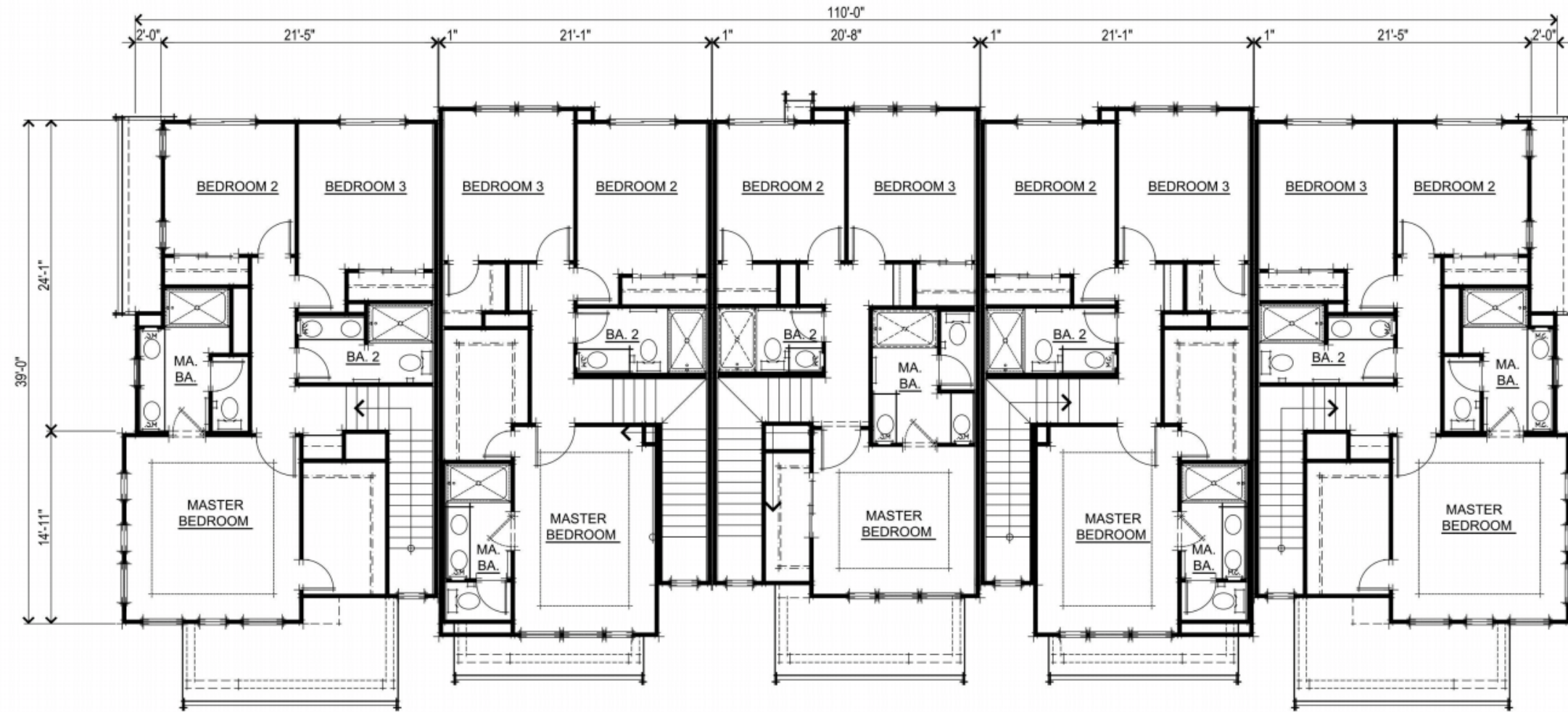

PLAN 3 REVERSE      PLAN 2 REVERSE      PLAN 1 REVERSE      PLAN 2 STANDARD      PLAN 3 STANDARD

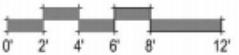

5 UNIT BUILDING THIRD FLOOR PLAN  
A.3-C

Telles Property  
Hayward, CA  
January 20, 2017

**KB Home**  
5000 Executive Parkway, Suite 125, San Ramon, CA 94583  
925.983.4500

3361 Walnut Blvd. Suite 120 Brentwood, CA 94513  
925.634.7000  
www.strausdesign.com



SDG Architects, Inc.

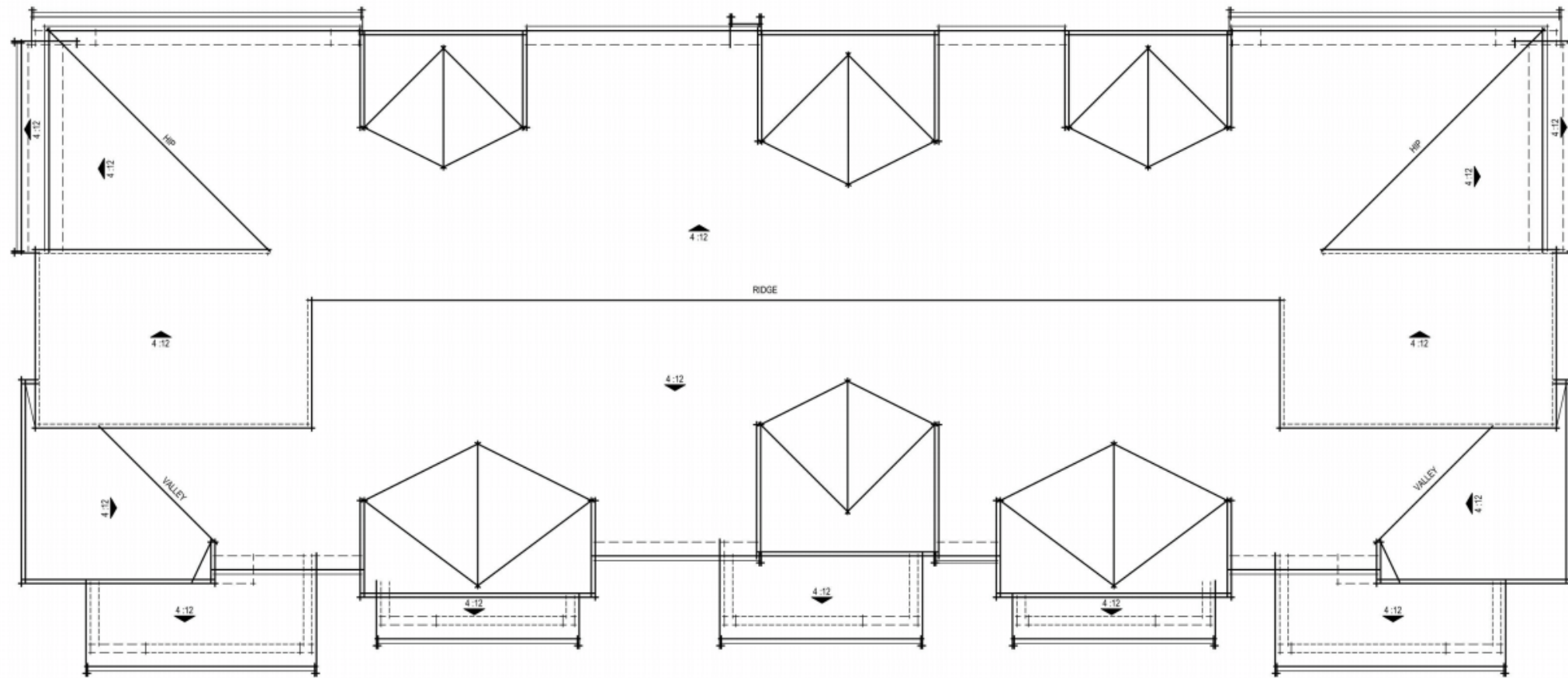

ROOF PLAN

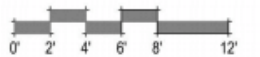

5 UNIT BUILDING ROOF PLAN  
A.4-C

Telles Property  
Hayward, CA  
January 20, 2017

KB Home

5000 Executive Parkway, Suite 125, San Ramon, CA 94583  
925.983.4500

3361 Walnut Blvd. Suite 120 Brentwood, CA 94513  
925.634.7000  
www.strausdesign.com



SDG Architects, Inc.



- TYPICAL EXTERIOR MATERIALS**
- ① - EXTERIOR PLASTER, MEDIUM SAND FINISH
  - ② - BOARD & BATTEN VERTICAL SIDING
  - ③ - FIBER CEMENT HORIZONTAL SIDING
  - ④ - PERFORATED MESH METAL RAILINGS
  - ⑤ - WOOD WINDOW TRIM @ SIDING
  - ⑥ - ARCHITECTURAL QUALITY COMPOSITION SHINGLE ROOFING

RIGHT ELEVATION



FRONT ELEVATION

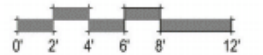

5 UNIT BUILDING FRONT & RIGHT ELEVATIONS  
A.5-C



- TYPICAL EXTERIOR MATERIALS
- ① - EXTERIOR PLASTER, MEDIUM SAND FINISH
  - ② - BOARD & BATTEN VERTICAL SIDING
  - ③ - FIBER CEMENT HORIZONTAL SIDING
  - ④ - PERFORATED MESH METAL RAILINGS
  - ⑤ - WOOD WINDOW TRIM @ SIDING
  - ⑥ - ARCHITECTURAL QUALITY COMPOSITION SHINGLE ROOFING

LEFT ELEVATION



REAR ELEVATION

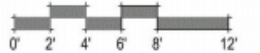

5 UNIT BUILDING REAR & LEFT ELEVATIONS  
A.6-C

Telles Property  
Hayward, CA  
August 3, 2017

KB Home

5000 Executive Parkway, Suite 125, San Ramon, CA 94583  
925.983.4500

3361 Walnut Blvd. Suite 120 Brentwood, CA 94513  
925.634.7000  
www.strausdesign.com



SDG Architects, Inc.





**GAF Roofing**  
Weathered Wood

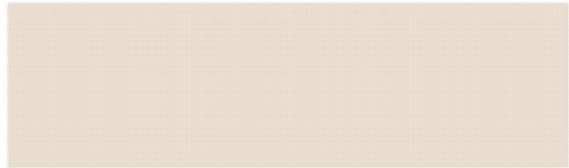

**Exterior Plaster 1**  
SW 6140 Moderate White



**Exterior Plaster 2**  
SW 7692 Cupola Yellow



**Vertical Siding**  
SW 7548 Portico



**Horizontal Siding**  
SW 7696 Toasted Pine Nut



**Trim & Fascia**  
SW 0023 Pewter Tankard



**Accent**  
SW 6179 Artichoke

*Note: All colors and textures are representative samples only, pending verification of actual material suppliers and manufacturers for this particular project.*

# DNS APARTMENT

HAYWARD, CA

## PROJECT DIRECTORY

**CLIENT**  
ROBERT L. TELLES

**LANDSCAPE ARCHITECT**  
GATES + ASSOCIATES  
271 CROW CANYON ROAD  
SAN RAMON, CA 94583  
PH: (925) 736-8176  
CONTACT: MELONIE O'SULLIVAN

**ARCHITECT**  
SDG ARCHITECTURE+ ENGINEERING  
3361 WALNUT BOULEVARD, SUITE 120  
BRENTWOOD, CA 94513  
PH: (925) 634-7000  
CONTACT: RALPH STRAUSS

**CIVIL ENGINEER**  
CARLSON, BARBEE & GIBSON  
2633 CAMINO RAMON, SUITE 350  
SAN RAMON, CA 94583  
PH: (925) 866-0322  
CONTACT: LEE ROSENBLATT

## GENERAL NOTES

1. THE CONTRACTOR AGREES THAT, IN ACCORDANCE WITH GENERALLY ACCEPTED CONSTRUCTION PRACTICES, THE CONTRACTOR WILL BE RESPONSIBLE TO ASSUME SOLE AND COMPLETE RESPONSIBILITY FOR JOB SITE CONDITIONS DURING THE COURSE OF CONSTRUCTION OF THE PROJECT, INCLUDING SAFETY OF ALL PERSONS AND PROPERTY. THIS REQUIREMENT SHALL BE MADE TO APPLY CONTINUOUSLY AND NOT BE LIMITED TO NORMAL WORKING HOURS. THE CONTRACTOR FURTHER AGREES TO DEFEND, INDEMNIFY AND HOLD OWNER AND ENGINEER HARMLESS FROM ANY AND ALL LIABILITY, REAL OR ALLEGED, IN CONNECTION WITH THE PERFORMANCE OF WORK ON THIS PROJECT, EXEMPTING LIABILITY ARISING FROM THE SOLE NEGLIGENCE OF ENGINEER.
2. EXCAVATIONS SHALL BE ADEQUATELY SHORED, BRACED AND SHEETED SO THAT THE EARTH WILL NOT SLIDE OR SETTLE AND SO THAT ALL EXISTING IMPROVEMENTS OF ANY KIND WILL BE FULLY PROTECTED FROM DAMAGE. ANY DAMAGE RESULTING FROM A LACK OF ADEQUATE SHORING, BRACING AND SHEETING, SHALL BE THE RESPONSIBILITY OF THE CONTRACTOR AND HE SHALL EFFECT NECESSARY REPAIRS OR RECONSTRUCTION AT HIS OWN EXPENSE. WHERE THE EXCAVATION FOR A CONDUIT TRENCH, AND/OR STRUCTURE IS FIVE FEET OR MORE IN DEPTH, THE CONTRACTOR SHALL PROVIDE ADEQUATE SHEETING, SHORING AND BRACING OR EQUIVALENT METHOD, FOR THE PROTECTION OF LIFE, OR LMB, WHICH SHALL CONFORM TO THE APPLICABLE CONSTRUCTION SAFETY ORDERS OF THE DIVISION OF INDUSTRIAL SAFETY OF THE STATE OF CALIFORNIA, THE CONTRACTOR SHALL ALWAYS COMPLY WITH OSHA REQUIREMENTS.
3. ALL APPLICABLE REQUIREMENTS OF THE CALIFORNIA CONSTRUCTION AND GENERAL INDUSTRY SAFETY ORDERS, THE OCCUPATIONAL SAFETY AND HEALTH ACT AND THE CONSTRUCTION SAFETY ACT SHALL BE MET.
4. IT IS THE RESPONSIBILITY OF THE CONTRACTOR TO OBTAIN PERMITS NECESSARY TO PERFORM THE WORK SHOWN IN THESE PLANS FROM THE APPROPRIATE AGENCIES.
5. THE CONTRACTOR SHALL TAKE EFFECTIVE ACTION TO PREVENT THE FORMATION OF AN AIRBORNE DUST NUISANCE AND SHALL BE RESPONSIBLE FOR ANY DAMAGE RESULTING FROM THEIR FAILURE TO DO SO.
6. THE CONTRACTOR MUST PROVIDE FOR SAFE ACCESSIBLE INGRESS AND EGRESS FOR ADJACENT PROPERTY OWNERS AND EVA THROUGHOUT THE PERIOD OF CONSTRUCTION. TEMPORARY THROUGH ACCESS FOR THE GENERAL PUBLIC DUE TO CONSTRUCTION STAGING OR LIMITATIONS MUST BE FULLY REVIEWED AND APPROVED BY THE OWNER PRIOR TO IMPLEMENTATION. ALL ACCESS MUST BE SAFE, SECURED, FLAGGED, SIGNED, AND ACCESSIBLE PER THE APPROVED SITE ACCESS PLAN SUBMITTED BY THE CONTRACTOR AND REQUIRED BY THE OWNER.
7. DURING CONSTRUCTION, THE CONTRACTOR SHALL BE RESPONSIBLE FOR EMERGENCY VEHICLE ACCESS, PUBLIC SAFETY AND SAFETY OF EXISTING STRUCTURES. THE CONTRACTOR SHALL PROVIDE ALL LIGHTS, SIGNS, FENCING, BARRICADES, TRAFFIC CONTROLS, FLAGGERS, SHORINGS, BRACING AND GUYS OR OTHER DEVICES NECESSARY TO PROVIDE FOR SAFETY IN ACCORDANCE WITH ALL NATIONAL, STATE SPECS AND LOCAL SAFETY ORDINANCES.
8. THE CONTRACTOR SHALL POST EMERGENCY TELEPHONE NUMBERS FOR POLICE, FIRE, AMBULANCE, AND THOSE AGENCIES RESPONSIBLE FOR MAINTENANCE OF UTILITIES IN THE VICINITY OF JOB SITE.
9. ALL EXISTING UTILITIES AND IMPROVEMENTS ARE SHOWN IN THEIR APPROXIMATE LOCATIONS BASED UPON RECORD INFORMATION AVAILABLE TO THE ENGINEER AT THE TIME OF PREPARATION OF THESE PLANS. LOCATIONS MAY NOT HAVE BEEN VERIFIED IN THE FIELD AND NO GUARANTEE IS MADE AS TO THE ACCURACY OR COMPLETENESS OF THE INFORMATION SHOWN. THE CONTRACTOR SHALL NOTIFY UTILITY COMPANIES AT LEAST THREE (3) WORKING DAYS IN ADVANCE OF CONSTRUCTION TO FIELD LOCATE UTILITIES. CALL UNDERGROUND SERVICE ALERT (U.S.A.), AT 800-227-2600. IT SHALL BE THE RESPONSIBILITY OF THE CONTRACTOR TO DETERMINE THE EXISTENCE AND LOCATION OF THOSE UTILITIES SHOWN ON THESE PLANS OR INDICATED IN THE FIELD BY LOCATING SERVICES. ADDITIONAL COSTS INCURRED AS A RESULT OF CONTRACTOR'S FAILURE TO VERIFY LOCATIONS OF EXISTING UTILITIES PRIOR TO BEGINNING OF CONSTRUCTION IN THEIR VICINITY SHALL BE BORNE BY THE CONTRACTOR AND ASSUMED INCLUDED AND MERGED IN THE CONTRACT UNIT PRICE.
10. ALL EXISTING UTILITIES AND IMPROVEMENTS THAT BECOME DAMAGED DURING CONSTRUCTION MUST BE COMPLETELY RESTORED TO THE SATISFACTION OF THE CITY ENGINEER OR UTILITY AGENCY REPRESENTATIVE, AT THE CONTRACTOR'S SOLE EXPENSE.
11. ANY RELOCATION OF PUBLIC UTILITIES SHALL BE CONDUCTED IN ACCORDANCE WITH ANY AND ALL REQUIREMENTS OF THE UTILITY COMPANY REPRESENTATIVE INCLUDING FEES, BONDS, PERMITS AND WORKING CONDITIONS, ETC. THIS WORK SHALL BE DONE AT NO EXPENSE TO THE UTILITY COMPANY. THE OWNER SHALL PAY THE COST OF ALL SUCH RELOCATION WORK INCLUDING FEES, BONDS, PERMITS, ETC.
12. THE CONSTRUCTION OF ALL GRAVITY UNDERGROUND LINES (STORM DRAINS) SHALL BEGIN AT THE MOST DOWNSTREAM END, UNLESS OTHERWISE SPECIFICALLY APPROVED BY ENGINEER OR BY THE OWNER.
13. IF ARCHEOLOGICAL MATERIALS ARE UNCOVERED DURING GRADING, TRENCHING OR OTHER EXCAVATION, EARTHWORK WITHIN 50 FEET OF THESE MATERIALS SHALL BE STOPPED UNTIL A PROFESSIONAL ARCHEOLOGIST WHO IS CERTIFIED BY THE SOCIETY OF CALIFORNIA ARCHAEOLOGY (SCA) AND/OR THE SOCIETY OF PROFESSIONAL ARCHAEOLOGY (SOPA) HAS HAD AN OPPORTUNITY TO EVALUATE THE SIGNIFICANCE OF THE FIND AND SUGGEST APPROPRIATE MITIGATION MEASURES, IF THEY ARE DEEMED NECESSARY.
14. THE USE OR INSTALLATION OF ANY MATERIAL OR EQUIPMENT WHICH IS MADE FROM, OR WHICH CONTAINS ASBESTOS FOR USE IN THE CONSTRUCTION OF THESE IMPROVEMENTS, IS NEITHER SPECIFIED NOR RECOMMENDED. ANY PARTY INSTALLING OR USING ANY PARTY SUCH MATERIALS OR EQUIPMENT SHALL BE SOLELY RESPONSIBLE FOR ALL INJURIES, DAMAGES, OR LIABILITIES OF ANY KIND, CAUSED BY THE USE OF SUCH MATERIALS OR EQUIPMENT.
15. THE CONTRACTOR MUST MEET AND IMPLEMENT ALL NPDES, SWPPP, AND EROSION CONTROL REQUIREMENTS IN EFFECT AT THE TIME OF CONSTRUCTION.
16. SHOULD IT APPEAR THAT THE WORK TO BE DONE OR ANY MATTER RELATIVE THERETO IS NOT SUFFICIENTLY DETAILED OR EXPLAINED ON THESE PLANS, THE CONTRACTOR SHALL CONTACT GATES & ASSOCIATES AT (925) 736-8176 FOR SUCH FURTHER EXPLANATIONS AS MAY BE NECESSARY.

## LAYOUT NOTES

1. CONTRACTOR SHALL VERIFY ALL UTILITIES, GRADES, EXISTING CONDITIONS AND DIMENSIONS IN THE FIELD PRIOR TO COMMENCING WORK. ALL DISCREPANCIES OR QUESTIONS SHALL BE BROUGHT TO THE ATTENTION OF THE LANDSCAPE ARCHITECT FOR RESOLUTION.
2. ALL WRITTEN DIMENSIONS SUPERCEDE ALL SCALED DISTANCES AND DIMENSIONS. DIMENSIONS SHOWN ARE FROM THE FACE OF THE BUILDING, WALL, BACK OF CURB, EDGE OF WALK, PROPERTY LINE, OR CENTERLINE OF COLUMN UNLESS OTHERWISE NOTED ON THE DRAWINGS.
3. ALL DIMENSIONS AT BUILDING ARE TO FACE OF BUILDING. ALL DIMENSIONS AT ROADWAY ARE TO FACE OF CURB.
4. ALL ANGLES ARE 45 DEGREE, 90 DEGREE, OR 135 DEGREE UNLESS OTHERWISE NOTED.
5. ALL CURVES AND ALL TRANSITIONS BETWEEN CURVES AND STRAIGHT EDGES SHALL BE SMOOTH.
6. ALL RETURN RADII AND CURB DATA ARE TO FACE OF CURB.
7. WHENEVER BOTTOM OF WALL (BW) ELEVATION IS GIVEN, IT IS FINISH PAVEMENT OR GRADE ELEVATION AT FACE OF WALL.
8. SCORE LINES IN SIDEWALKS SHALL BE SPACED TO EQUAL THE WIDTH OF THE WALKWAY, UNLESS OTHERWISE SHOWN. EXPANSION JOINTS IN SIDEWALKS SHALL BE 20' ON CENTER MAXIMUM.
9. EXPANSION JOINTS IN CONCRETE WALLS SHALL BE AT 40' O.C. MAXIMUM.
10. BUILDING LAYOUT AND LOCATION, SIDEWALK, CURB AND GUTTER, GRADING AND DRAINAGE IS BASED ON DRAWINGS PREPARED BY THE ARCHITECT AND THE CIVIL ENGINEER.
11. STATIONING HEREON IS ALONG CONSTRUCTION CENTERLINE UNLESS OTHERWISE SHOWN OR INDICATED.
12. ANY EXTRA CONSTRUCTION STAKING NECESSITATED SOLELY BY THE CONTRACTOR'S NEGLIGENCE WILL BE CHARGED TO THE CONTRACTOR ON A TIME AND EXPENSES BASIS AND PAID FOR BY THE CONTRACTOR.
13. SEE IRRIGATION DRAWINGS FOR GENERAL SYSTEM REQUIREMENTS AND FOR LOCATION OF IRRIGATION MAINLINE PIPING. SLEEVES TO ACCOMMODATE IRRIGATION PIPING, SIZED AS NEEDED, SHALL BE IN PLACE UNDER AND THROUGH SLABS AND WALLS, PRIOR TO POURING.
14. PROVIDE CONTINUOUS HEADERS AT THE EDGES OF ALL AC PAVING, SHRUB AREAS, LAWN AREAS, DECOMPOSED GRANITE WHERE IT IS NOT CONSTRAINED BY A CONCRETE PAVING OR MOW BAND.
15. ALL CONCRETE PAVEMENTS SHALL BE DOWELED INTO CURBS, SIDEWALKS, AND BUILDING FOUNDATIONS.
16. REFER TO GEOTECHNICAL REPORT FOR ADDITIONAL INFORMATION, SECTIONS, REINFORCEMENT, AND PREPARATION. IN CASE OF DISCREPANCY THE GEOTECHNICAL REPORT SHALL GOVERN.
17. ALL TYPICAL DETAILS SHALL APPLY UNLESS NOTED OTHERWISE.
18. ANY AND ALL WORK WITHIN CITY RIGHT OF WAY SHALL CONFORM TO ALL CITY STANDARD DETAILS AND SPECIFICATIONS.
19. CONCRETE FOOTINGS INSTALLED FOR ALL SITE FURNISHINGS, SPORTS EQUIPMENT, ETC., IN DECORATIVE PAVEMENT, ASPHALT PAVING, DECOMPOSED GRANITE, CONCRETE PAVING, AND PLANTERS SHALL BE HELD BELOW GRADE.
20. ALL EXISTING ITEMS TO REMAIN SHALL BE PROTECTED AS REQUIRED. ANY DAMAGED ITEMS SHALL BE FULLY REPAIRED OR REPLACED AT THE CONTRACTOR'S EXPENSE TO THE FULL SATISFACTION OF THE OWNER.
21. CONTRACTOR SHALL BE RESPONSIBLE FOR ANY COORDINATION WITH SUBCONTRACTORS AS REQUIRED TO ACCOMPLISH OPERATIONS.
22. ALL QUANTITIES AND PAY ITEMS ARE AND WILL BE BASED ON HORIZONTAL MEASUREMENTS.
23. ALL PATTERNS, LINE TYPES, AND SYMBOLS SHOWN WITHIN THE PLAN SET REFERENCE THE LAYOUT LEGEND AND ARE PART OF THE SCOPE OF WORK. CALLOUTS ARE SHOWN FOR CLARIFICATION OF WORK, BUT DO NOT INDICATE EVERY AND ALL INSTANCES OF SUCH WORK. THE CONTRACTOR SHALL REQUEST CLARIFICATION TO ANY ITEMS (INCLUDING BUT NOT LIMITED TO PAVING, WALLS, FINISHES, COLORS, FENCING, FOUNTAINS, POTS, AND SITE FURNITURE) NOT CLEARLY IDENTIFIED TO BE PART OF THE SCOPE OF WORK PRIOR TO BID.

## SHEET INDEX

Sheet Number	Sheet Title
L0.1-A	COVER SHEET
L0.2-A	NOTES AND LEGEND
L0.3-A	PLANTING NOTES
L0.4-A	HYDROZONE PLAN
L1.1-A	LAYOUT PLAN
L2.1-A	PLANTING PLAN
L3.1-A	IRRIGATION PLAN
L3.2-A	IRRIGATION DETAILS
L3.3-A	IRRIGATION DETAILS
L3.4-A	IRRIGATION DETAILS
L3.5-A	IRRIGATION DETAILS
L3.6-A	IRRIGATION DETAILS
L3.7-A	IRRIGATION DETAILS
L5.1-A	CONSTRUCTION DETAILS
L5.2-A	CONSTRUCTION DETAILS

## WATER EFFICIENT LANDSCAPE STATEMENT

I HAVE COMPLIED WITH THE CRITERIA OF THE CITY OF HAYWARD BAY FRIENDLY WATER EFFICIENT LANDSCAPE ORDINANCE AND APPLIED THEM FOR THE EFFICIENT USE OF WATER IN THE LANDSCAPE AND IRRIGATION DESIGN PLAN.

## LOCATION MAP

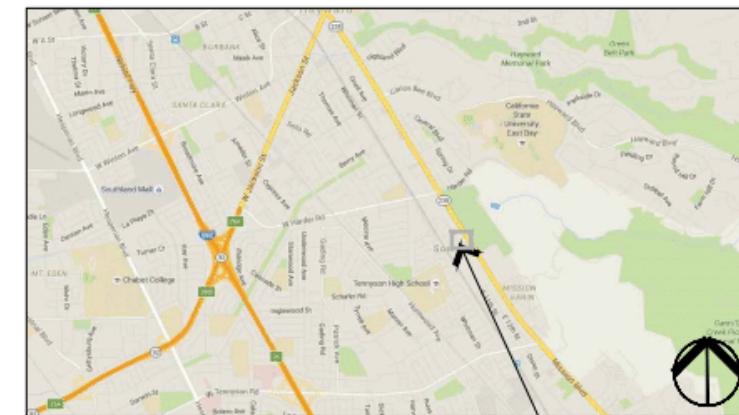

PROJECT SITE

**GATES**  
**+ASSOCIATES**  
LANDSCAPE ARCHITECTURE  
LAND PLANNING • URBAN DESIGN  
2671 CROW CANYON RD. SAN RAMON, CA 94583  
7 925.736.8176 www.gates.com

**DNS**  
**APARTMENTS**

HAYWARD  
CALIFORNIA

ISSUE	DESCRIPTION	DATE
ISSUE 1	PLAN REVIEW	04-21-16
ISSUE 2	2ND PLAN REVIEW	10-03-16
ISSUE 3	3RD PLAN REVIEW	01-19-17
ISSUE 4	4TH PLAN REVIEW	04-04-17
ISSUE 5	5TH PLAN REVIEW	06-30-17

**NOT FOR**  
**CONSTRUCTION**















PROJECT NUMBER:  
DRAWN: MM  
CHECK: MNO  
DATE: 04-04-17  
SCALE:



COVER SHEET

**L0.1-A**

# LAYOUT LEGEND





-  PEDESTRIAN CONCRETE PAVING  
FINISH: MEDIUM BROOM  
COLOR: STANDARD GREY  
ALL PEDESTRIAN CONCRETE PAVING AT PATIO SHALL BE STANDARD GREY COLOR WITH SALT FINISH. 3  
15.3-A
-  ACCENT CONCRETE PAVING  
FINISH: MEDIUM BROOM  
COLOR: TBD 3  
15.3-A
-  PERMEABLE PAVERS AT PARKING  
MFR: BASALITE
-  STAMPED AC PAVING  
COLOR AND PATTERN: TBD
-  CMU PERIMETER WALL 2  
15.2-A
-  FENCE AT BIO-RETENTION 4  
15.2-A
- SCORELINE
- EJ EXPANSION JOINT
-  POINT OF BEGINNING
- TYP. TYPICAL
- EQ. EQUAL
- S.C.D. SEE CIVIL'S DRAWINGS
- S.A.D. SEE ARCHITECT'S DRAWINGS
- S.E.D. SEE ELECTRICAL'S DRAWINGS
- SBM SIMILAR
- R RADIUS - ALL RADII GIVEN FOR WALLS ARE DIMENSIONED TO OUTSIDE OF WALLS.
-  ALIGN
-  CENTER LINE
- SP. SPACING
- F.O.C. FACE OF CURB
-  BIO-RETENTION IN PLANTING AREAS, S.C.D
-  PLANTING AREA
-  Existing Tree to Remain

# PLANTING LIST

TREES	BOTANICAL NAME	COMMON NAME	SIZE	SPACING	WATER USE (WUCOLS IV)	MATURE SIZE
CO	Cercis canadensis	Eastern Redbud	15 GAL	As Shown	VL	25'-0"
ED	Elaeocarpus decipens	Japanese Blueberry	15 GAL	As Shown	L	25'-0"
PC	Pistacia chinensis	Chinese Pistache	24" Box	As Shown	L	40'-0"
LM	Lagerstroemia hybrids 'Natchez'	Crape Myrtle	15 GAL	As Shown	L	12'-0"
PA	Platanus acerifolia 'Columbia'	London Plane Tree	36" Box	As Shown	M	30'-0"
<b>SHRUBS</b>						
BB	Berberis buxifolia 'Nana'	Dwarf Magellan Barberry	1 Gal	2'-0" O.C.	M	2'-0"
BW	Buddleja x weyeriana 'Bicolor'	Butterfly Bush	5 Gal	4'-6" O.C.	L	6'-0"
CS	Coleonema 'Sunset Gold'	Golden Breath of Heaven	1 Gal	3'-6" O.C.	M	4'-0"
DV	Dietes grandiflora 'Variegata'	Striped Fortnight Lily	5 Gal	3'-0" O.C.	L	3'-0"
HS	Helictotrichon sempervirens	Blue Oat Grass	1 Gal	3'-0" O.C.	L	3'-0"
LT	Lavatera 'Red Rum'	Tree Mallow	5 Gal	4'-0" O.C.	L	4'-0"
IL	Lomandra longifolia 'Breeze'	Dwarf Mat Rush	1 Gal	3'-0" O.C.	L	3'-0"
LU	Leucadendron 'Safari Sunset'	Safari Conebush	5 Gal	5'-0" O.C.	L	6'-0"
MC	Myrtus communis	Myrtle	5 Gal	3'-6" O.C.	L	4'-6"
PS	Pennisetum alopecuroides 'Hameln'	Dwarf Fountain Grass	1 Gal	3'-0" O.C.	L	3'-0"
PH	Penstemon heterophyllus 'Margarita BOP'	Margarita BOP	1 Gal	2'-6" O.C.	L	2'-6"
PG	Phormium tenax 'Wings of Gold'	Dwarf Variegated Flax	1 Gal	3'-0" O.C.	L	3'-0"
RY	Rosa 'Carpet Rose Yellow'	Yellow Carpet Rose	1 Gal	3'-0" O.C.	L	3'-6"
SE	Senecio madraliscae	Blue Chalk Sticks	1 Gal	2'-0" O.C.	L	2'-0"
SM	Salvia microphylla 'Hot Lips'	Hot Lips Sage	1 Gal	3'-0" O.C.	L	3'-0"
TL	Teucrium lucidrys 'Prostrata'	Groundcover Germander	1 Gal	3'-6" O.C.	L	4'-0"
<b>GROUNDCOVERS</b>						
EG	Erigeron glaucus	Beach Aster	1 Gal	18" O.C.	L	18"
EK	Erigeron karvinskianus	Fleabane	1 Gal	2'-6" O.C.	L	3'-0"
LM	Lantana montevidensis	Creeping Lantana	1 Gal	4" O.C.	L	4'-0"
OF	Osteospermum fruticosum 'Cream Symphony'	African Trailing Daisy	1 Gal	3'-0" O.C.	L	3'-6"
RSS	Senecio serpens	Blue Chalksticks	1 Gal	18" O.C.	L	18" O.C.
<b>VINES</b>						
CC	Clytostoma callistegioides	Violet Trumpet Vine	5 Gal	As Shown	L	N/A

**WATER USE RATING LEGEND:**  
WUCOLS III CATEGORIES OF WATER NEEDS FROM: UNIVERSITY OF CALIF COOPERATIVE EXTENSION, CALIF DEPARTMENT OF WATER RESOURCES, U.S. BUREAU OF RECLAMATION  
H = HIGH  
M = MODERATE  
L = LOW  
VL = VERY LOW

# PLANTING LEGEND

-  TREE NAME QUANTITY
-  SHRUB NAME QUANTITY
-  GROUNDCOVER QUANTITY
-  VINE QUANTITY

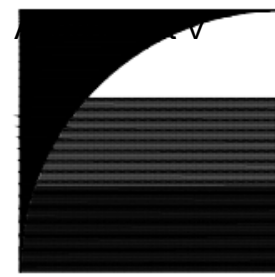

**GATES + ASSOCIATES**  
LANDSCAPE ARCHITECTURE  
LAND PLANNING • URBAN DESIGN  
2871 CROW CANYON RD. SAN RAMON, CA 94583  
7 925.734.8176 www.gates.com

## DNS APARTMENTS

HAYWARD  
CALIFORNIA

ISSUE	DESCRIPTION	DATE
ISSUE 1	PLAN REVIEW	04-21-16
ISSUE 2	2ND PLAN REVIEW	10-03-16
ISSUE 3	3RD PLAN REVIEW	01-19-17
ISSUE 4	4TH PLAN REVIEW	04-06-17
ISSUE 5	5TH PLAN REVIEW	06-30-17

**NOT FOR CONSTRUCTION**



PROJECT NUMBER:  
DRAWN: MM  
CHECK: MNO  
DATE: 04-04-17  
SCALE:



NOTES AND LEGEND

# L0.2-A

# PLANTING NOTES

## GENERAL

- ALL WORK SHALL BE PERFORMED BY PERSONS FAMILIAR WITH PLANTING WORK AND UNDER THE SUPERVISION OF A QUALIFIED PLANTING FOREMAN.
- ALL QUANTITIES AND PLANT COUNTS ARE FOR THE CONVENIENCE OF THE CONTRACTOR. IN CASE OF DISCREPANCIES, THE PLAN SHALL GOVERN.
- THE LANDSCAPE ARCHITECT RESERVES THE RIGHT TO MAKE SUBSTITUTIONS, ADDITIONS, AND DELETIONS IN THE PLANTING SCHEME AS THEY FEEL NECESSARY WHILE WORK IS IN PROGRESS, UPON APPROVAL BY THE OWNER. SUCH CHANGES ARE TO BE ACCOMPANIED BY EQUITABLE ADJUSTMENTS IN THE CONTRACT PRICE, WHEN NECESSARY.
- PLANT MATERIAL LOCATIONS SHOWN ARE DIAGRAMMATIC AND MAY BE SUBJECT TO CHANGE IN THE FIELD BY THE LANDSCAPE ARCHITECT. PLANT LOCATIONS ARE TO BE ADJUSTED IN THE FIELD AS NECESSARY TO SCREEN UTILITIES, BUT SHALL NOT BLOCK WINDOWS, BLOCK SIGNS NOR IMPEDE ACCESS.
- THE DESIGN INTENT OF THE PLANTING PLAN IS TO ESTABLISH AN ATTRACTIVE MATURE LANDSCAPE APPEARANCE. FUTURE PLANT GROWTH WILL NECESSITATE TRIMMING, SHAPING, AND IN SOME CASE REMOVAL OF TREES AND SHRUBS AS AN ON-GOING MAINTENANCE PROCEDURE.
- ALL PLANTING AREA MUST BE IRRIGATED WITH AUTOMATIC IRRIGATION SYSTEM. IRRIGATION SYSTEM SHALL BE FULLY AUTOMATED AND OPERATIONAL WITH FULL COVERAGE PRIOR TO PLANTING.
- CONTRACTOR TO REVIEW ALL EXISTING, PROPOSED, & AS BUILT UTILITY PLANS PRIOR TO CONSTRUCTION. CONTRACTOR TO TAKE PRECAUTIONS IN EXCAVATION OF ALL TREE PLANTING PITS. CONTRACTOR TO NOTIFY LANDSCAPE ARCHITECT OF ANY CONFLICTS FOUND DURING CONSTRUCTION.
- CONTRACTOR MUST REVIEW ALL PLANS PRIOR TO THE BEGINNING OF CONSTRUCTION AND MAINTAIN THE FOLLOWING CLEARANCES FOR ALL TREE PLANTINGS. CONTRACTOR TO TAKE PRECAUTION IN ALL EXCAVATION ACTIVITY. NOTIFY LANDSCAPE ARCHITECT OF ANY CONFLICTS PRIOR TO INSTALLATION.
  - FIRE HYDRANTS AND PVS: 3' MINIMUM
  - LIGHT POLES: 10' MINIMUM
  - UTILITIES: 3' MINIMUM
  - BUILDING ROOF EDGE: 5' MINIMUM
- CONTRACTOR TO PROVIDE AND ARRANGE FOR PLANT MATERIAL THRU CONTRACT GROW, PLANT BROKERS, OR DIRECT PURCHASE AS REQUIRED FOR THE FULL IMPLEMENTATION OF THE PROJECTS PLANTING PLAN. CONTRACTOR MUST SUBMIT WITHIN 30 DAYS AFTER AWARD OF A BID A DETAILED NURSERY LIST OF SECURED PLANT MATERIAL, CONTRACT GROW PLANT MATERIAL, AND ANY SUBSTITUTION REQUESTS. CONTRACTOR SHALL ARRANGE AND SECURE ALL PLANT MATERIAL WITHIN 30 DAYS OF BID. UPON DELIVERY, PLANT MATERIAL THAT DOES NOT MEET NURSERY STANDARDS, IS ROOTBOUND, OF POOR QUALITY & HEALTH, SUBSTANDARD SIZE, AND / OR IS NOT APPROVED BY THE LANDSCAPE ARCHITECT SHALL BE REPLACED AT THE CONTRACTORS EXPENSE. MATERIAL WHICH IS NOT SECURED AND IS UNAVAILABLE IN THE SIZE SPECIFIED SHALL BE UP-SIZED, IF AVAILABLE. ALL REPLACEMENT MATERIAL, SUBSTITUTIONS OR UP-SIZED PLANT MATERIAL MUST BE PROVIDED AS REQUIRED FOR THE FULL IMPLEMENTATION OF THE PLANTING PLAN AT NO ADDITIONAL COST TO THE CONTRACT AND OWNER.
- PROCUREMENT OF PLANT MATERIAL SHALL NOT BE LIMITED TO NORTHERN CALIFORNIA. CONTRACTOR SHALL BE RESPONSIBLE FOR ALL TRUCKING, INSPECTIONS, AND INCIDENTALS FOR PROVIDING PLANT MATERIAL FROM SOURCES OUT OF STATE AS REQUIRED BY THE PROJECT PLANTING PLAN.

## EXISTING PLANT MATERIAL

- ALL EXISTING PLANT MATERIAL, TREES, OR LAWN TO REMAIN MUST BE PROTECTED AND MAINTAINED IN PLACE BY THE CONTRACTOR.
- ANY DAMAGED MATERIAL MUST BE FULLY REPLACED TO MATCH EXISTING BY THE CONTRACTOR AT NO ADDITIONAL COST TO THE CONTRACT AND OWNER.
- CONTRACTOR MUST MAINTAIN ANY EXISTING IRRIGATION SYSTEMS OR PROVIDE TEMPORARY IRRIGATION SYSTEMS AS REQUIRED TO ALL EXISTING PLANTING AREAS TO REMAIN.

## SOILS

- THE CONTRACTOR MUST PROVIDE AN AGRICULTURAL SUITABILITY ANALYSIS FOR ALL SOILS EXISTING AND IMPORTED INCLUDING BUT NOT LIMITED TO: EXISTING ON-SITE SOILS, IMPORTED TOPSOIL, LIME TREATED AREAS, AND ALL AMMENDMENTS. RECOMMENDATIONS FOR AMENDMENTS CONTAINED IN THIS ANALYSIS ARE TO BE CARRIED OUT BEFORE PLANTING OCCURS. PROVIDE 2 TESTS AT 6" DEPTH AND 2 TESTS AT 24" DEPTH THROUGHOUT THE SITE. PROVIDE ADDITIONAL TESTING (ONE 6" AND ONE 24" DEPTH TEST PER 25,000 SF FOR AREAS WHICH WERE LIME TREATED). EACH TEST SAMPLE SHALL CONTAIN 3 REPRESENTATIVE SOIL SAMPLES. ALL LIME TREATED PLANTING AREAS SHALL BE REMOVED AND REPLACED WITH IMPORT TOP SOIL AT NO COST TO THE OWNER. ALL TESTING SHALL BE PAID FOR BY THE CONTRACTOR. FOR BID PURPOSES AMEND ALL SOIL WITH 6 YARDS OMRI COMPOST 50LBS GYPSUM AND 100LBS OF GRO-POWER PLUS 5-3-1 W/ M PER 1000SF. CONTRACTOR TO SUBMIT ALL DELIVERY TICKETS FOR COMPOST AND FERTILIZERS FOR VERIFICATION.
- ALL SOILS IMPORTED ONTO THE SITE FOR ANY PURPOSE SUCH AS GRADING, NON EXPANSIVE FILL, FILL, OR FOR ANY GENERAL PURPOSE MUST BE TESTED FOR PLANT SUITABILITY PRIOR TO PLACEMENT. ALL IMPORT SOILS SHALL BE NON-DETRIMENTAL TO PLANT MATERIAL AND SOILS ANALYSIS SUBMITTED TO THE LANDSCAPE ARCHITECT FOR REVIEW AND APPROVAL. PROVIDE 1 TEST PER 500 CY OF MATERIAL.
- SOIL IS TO BE AMENDED, AT THE RATE INDICATED BY THE SOIL ANALYSIS, TO BRING THE SOIL ORGANIC MATTER CONTENT TO A MINIMUM OF 3.5% BY DRY WEIGHT, AND A MINIMUM OF 2" OF QUALITY RECYCLED COMPOST, ON ALL PLANTING AREAS.
- ALL PLANTERS IN AREAS WHICH HAVE BEEN COMPACTED, SUCH AS ADJACENT TO BUILDINGS AND IN PARKING LOTS, SHALL BE CROSS RIPPED TO THE FOLLOWING DEPTHS: PLANTERS LESS THAN THREE (3) FEET WIDE SHALL HAVE COMPACTION RELIEVED TO A MINIMUM DEPTH OF TWENTY-FOUR (24) INCHES BELOW SUBGRADE. PLANTERS THREE TO TEN (3-10) FEET WIDE MUST HAVE COMPACTION RELIEVED TO A MINIMUM DEPTH OF 18" BELOW SUBGRADE, PLANTERS MORE THAN 10' WIDE SHALL HAVE COMPACTION RELIEVED TO A MINIMUM DEPTH OF 12" BELOW SUBGRADE. AREAS SHALL BE PROTECTED AFTER DECOMPACTION.
- CONTRACTOR SHALL PERFORM A PERCOLATION TEST AT THE BEGINNING OF CONSTRUCTION AT 1 LOCATION PER ACRE (MAX OF 4) TO DETERMINE THE DRAINAGE CAPACITY OF THE EXISTING SITE SOIL FOR TREE HEALTH. NOTIFY THE LANDSCAPE ARCHITECT IF DRAINAGE IS LESS THAN 2" PER HOUR.

# PLANTING NOTES

## SHRUBS, GROUNDCOVERS AND VINES

- GROUNDCOVER MUST BE PLANTED AS SHOWN ON THE PLAN, INCLUDING UNDER SHRUBS AND IN TREE WATERING BASINS.
- SHRUBS AND PERENNIALS MUST HAVE ADEQUATE SETBACK FROM THE ADJACENT SIDEWALK AND EDGES OF PARKING LOT CURBS. NOTIFY LANDSCAPE ARCHITECT PRIOR TO INSTALLATION IF PLANT MATERIAL MAY PROTRUDE INTO THE PATH OF TRAVEL.
- THE CONTRACTOR IS TO SECURE ALL VINES TO TRELLISES WITH APPROVED FASTENERS, ALLOWING FOR TWO (2) YEARS GROWTH. SUBMIT SAMPLE TO LANDSCAPE ARCHITECT.

## HYDROSEED

- ALL DISTURBED AREAS WITH NO PLANTING, MULCH, HARDSCAPE OR OTHER MEANS OF EROSION CONTROL SHALL HAVE HYDROSEED PLACED.
- ALL HYDROSEED SHALL BE FULLY ROOTED AND ESTABLISHED PRIOR TO OCTOBER 15TH.
- THE CONTRACTOR SHALL PROVIDE TEMPORARY IRRIGATION AS REQUIRED TO ESTABLISH ALL 'NON-IRRIGATED' HYDROSEED WITHIN FLOW CHANNELS, RETENTION BASINS, DETENTION BASINS, OR OTHER AREAS SUBJECT TO WATER FLOW.

## ACCESSORIES

- ALL PLANTING NOT BOUNDED BY CONCRETE OR A HARDSCAPE EDGE SHALL BE COMPLETELY SURROUNDED BY HEADERS. ALL ASPHALT AND DECOMPOSED GRANITE AREAS TO BE COMPLETELY SURROUNDED BY HEADERS OR ADJACENT CONCRETE WORK.
- ALL PLANTING AREAS SHALL BE TOP-DRESSED WITH 3" LAYER OF ORGANIC RECYCLED CHIP MULCH - DARK BROWN. THIS MULCH IS SUITABLE AS STABILIZING MULCH ON SLOPES GREATER THAN 4:1.
- ALL STORMWATER CURB CUTS MUST BE REINFORCED WITH A MINIMUM 12" WIDE x 18" LONG x 8" DEEP BAND OF COBBLE. COBBLE SHALL BE 40% 4"-6" AND 60% 2"-3" NOYO COBBLE. PROVIDE 24" WIDE BY 6" DEPTH OF COBBLE AROUND ALL CATCH BASINS LOCATED IN DRAINAGE AREAS. SUBMIT SAMPLE FOR REVIEW AND APPROVAL.
- ALL RAINWATER LEADERS DISCHARGING INTO LANDSCAPE AREAS MUST HAVE SPLASH BLOCKS. MODEL: CDI 16X24". COLOR: TO MATCH PAVING. (800) 279-2278.
- ALL SLOPES GREATER THAN 2.5:1 MUST BE COVERED WITH EROSION CONTROL NETTING PER THE MANUFACTURERS SPECIFICATIONS. OVERLAP ALL EDGES A MINIMUM OF 12" AND SECURE AS REQUIRED WITH METAL STAPLES. EROSION CONTROL NETTING TO BE WESTERN EXCELSIOR, EXCEL CS-3 OR APPROVED EQUAL. AVAILABLE FROM REED & GRAHAM 888-381-0800.
- THE LANDSCAPE CONTRACTOR SHALL AS A PART OF THIS BID PROVIDE FOR A PLANTING ALLOWANCE FOR THE AMOUNT OF \$3,000.00 (THREE THOUSAND DOLLARS), TO BE USED FOR SUPPLYING AND INSTALLING ADDITIONAL PLANT MATERIAL AS DIRECTED BY THE LANDSCAPE ARCHITECT AND APPROVED BY THE OWNER IN WRITING. THE UNUSED PORTION OF THE ALLOWANCE SHALL BE RETURNED TO THE OWNER AT THE BEGINNING OF THE MAINTENANCE PERIOD.

- SEE SPECIFICATIONS FOR ALL FERTILIZER REQUIREMENTS

## SUBMITTALS

- CONTRACTOR MUST SUBMIT ALL TESTS, PRODUCTS, ACCESSORIES, CUT SHEETS OF ALL ITEMS SPECIFIED FOR REVIEW AND APPROVAL PRIOR TO INSTALLATION.
- ALL PLANT MATERIAL MUST BE REVIEWED AND APPROVED BY THE LANDSCAPE ARCHITECT PRIOR TO DELIVERY. CONTRACTOR SHALL SUBMIT PHOTOS OF ALL SHRUBS, GROUND COVERS, VINES, AND TREES FOR PRELIMINARY REVIEW AND APPROVAL.
- PLANT MATERIAL NOT APPROVED BY THE LANDSCAPE ARCHITECT MAY BE SUBJECT TO REMOVAL AND REPLACEMENT WITH APPROVED PLANT MATERIAL AT NO ADDITIONAL COST TO THE CONTRACT OR OWNER.

## MUNICIPAL REQUIREMENTS

- ALL PLANT MATERIAL TO BE INSPECTED & APPROVED BY CITY REPRESENTATIVE AND LANDSCAPE ARCHITECT PRIOR TO INSTALLATION.
- CONTACT THE PROJECT LANDSCAPE ARCHITECT FOR FINAL INSPECTION OF LANDSCAPE AND IRRIGATION. PRIOR TO RELEASE OF BUILDING FOR OCCUPANCY, THE PROJECT LANDSCAPE ARCHITECT WILL SUBMIT A LETTER TO THE CITY CERTIFYING THE PLANTING AND IRRIGATION HAS BEEN INSTALLED IN CONFORMANCE WITH THE APPROVED PLANTING AND IRRIGATION PLANS, SUBJECT TO THE REVIEW AND APPROVAL OF THE CITY LANDSCAPE ARCHITECT. SECURITIES IN LIEU OF INSTALLATION WILL NOT BE ACCEPTED.
- DURING THE INSTALLATION OF LANDSCAPING AND INSTALLATION AND PRIOR TO THE ISSUANCE OF A BUILDING OCCUPANCY PERMIT, THE LANDSCAPE ARCHITECT MUST INSPECT AND MONITOR THE INSTALLATION OF MATERIALS TO VERIFY CONFORMANCE TO THESE PLANS. ONCE APPROVED, THE LANDSCAPE ARCHITECT SHALL PROVIDE A WRITTEN LETTER TO DEPARTMENT OF PLANNING AND DEVELOPMENT STATING COMPLIANCE WITH THE APPROVED PLANS.

# WATER CONSERVATION STATEMENT

- THE PLANT LIST IS PRELIMINARY IN NATURE. SPECIES SHALL BE ADDED AND SUBTRACTED TO FULFILL THE DESIGN AND HORTICULTURAL REQUIREMENTS AS NECESSARY.
- THE IRRIGATION SYSTEM SHALL BE DESIGNED WITH WATER CONSERVATION IN MIND WHILE ACHIEVING THE GOAL OF EFFECTIVELY AND EFFICIENTLY PROVIDING THE LANDSCAPE WITH WATER BY MEANS OF SPRAY IRRIGATION TO THE SHRUBS/GROUND COVER AREAS AND BUBBLERS TO THE TREES.
- THE SPRAY SYSTEM SHALL BE TORO SPRAY HEADS WITH PRESSURE COMPENSATING NOZZLES IN A HEAD TO HEAD LAYOUT TO ACHIEVE AN EVEN LEVEL OF PRECIPITATION THROUGHOUT THE IRRIGATION SYSTEM.
- A STATE-OF-THE-ART IRRIGATION CONTROLLER SHALL BE SPECIFIED FOR THIS PROJECT TO CONTROL THE WATER ALLOCATED TO EACH VALVE GROUPED PER INDIVIDUAL HYDROZONE (BASED ON PLANT TYPE AND EXPOSURE).

# PLANTING NOTES

## TREES

- ALL TREES SHALL BE SPECIMENS UNLESS SPECIFICALLY NOTED.
- ALL TREES ARE TO BE STAKED AS SHOWN ON THE TREE STAKING/GUYING DIAGRAMS. BRANCHING HEIGHT OF TREES SHALL BE A 6'-0" MINIMUM ABOVE FINISH GRADE. ALL TREES IN A FORMAL GROUP PLANTING MUST BE MATCHING IN SIZE AND SHAPE. ALL STREET TREES TO BE INSTALLED IN ACCORDANCE WITH THE STANDARDS AND SPECIFICATIONS OF THE OWNER. LANDSCAPE ARCHITECT SHALL BE CONSULTED REGARDING ORIENTATION OF TREES PRIOR TO PLANTING AND/OR BACKFILLING.
- PLANT TREES 3'-0" MINIMUM FROM FACE OF CURB AT PARKING, AND FROM EDGES OF PAVING. ALL TREES WITHIN 5' OF PAVING AREAS AND BUILDINGS MUST HAVE ROOT BARRIERS INSTALLED. SEE ROOT BARRIER DETAIL. DEEP ROOT BARRIER MODEL NO. UR242 (415) 344-1464. INSTALL PER MANUFACTURERS SPECIFICATIONS. WHERE WATER BARRIERS AND ROOT BARRIERS ARE REQUIRED, USE CENTURY PRODUCTS DUAL PURPOSE WATER/ ROOT BARRIER CR-P24-20, (714)632-7083, S.C.D. FOR LOCATIONS OF WATER BARRIER.
- PROVIDE 4" BERM AROUND TREE FOR WATER BASIN. SEE TREE STAKING DETAIL. BERM TO BE REMOVED IN LAWN AREA AFTER INITIAL MAINTENANCE PERIOD. MULCH TREE WELL WITH 3" LAYER OF RECYCLED CHIPPED MULCH. KEEP MULCH AWAY FROM TREE TRUNK. HOLD LAWN AND HYDROSEED 2' CLEAR FROM TRUNKS, TYP.
- TREES MUST HAVE AN UN CUT LEADER THAT HAS A UNIFORM TAPER FROM BASE TO TIP. TREES MUST MEET AT LEAST NORMAL CALIPER AND HEIGHT FOR CONTAINER SIZE. OVERGROWN OR ROOT BOUND TREES ARE NOT ACCEPTABLE.
- FOR ALL TREES IN STORMWATER INFILTRATION ZONES HOLD FG OF ROOTBALL 4" ABOVE FG OF FLOWLINE. ADJUST ADJACENT GRADE OF SOIL TO BLEND UNIFORMLY AROUND ROOTBALL AND ALLOW UNIMPEDED FLOW OF WATER.

# WATER EFFICIENT LANDSCAPE STATEMENT

I HAVE COMPLIED WITH THE CRITERIA OF THE CITY OF HAYWARD BAY FRIENDLY WATER EFFICIENT LANDSCAPE ORDINANCE AND APPLIED THEM FOR THE EFFICIENT USE OF WATER IN THE LANDSCAPE AND IRRIGATION DESIGN PLAN.



**GATES + ASSOCIATES**

LANDSCAPE ARCHITECTURE  
LAND PLANNING • URBAN DESIGN

2671 CROW CANYON RD. SAN RAMON, CA 94583  
7 925.734.4176 www.gates.com

**DNS APARTMENTS**

HAYWARD  
CALIFORNIA

ISSUE	DESCRIPTION:	DATE:
ISSUE 1	PLAN REVIEW	04-21-16
ISSUE 2	2ND PLAN REVIEW	10-03-16
ISSUE 3	3RD PLAN REVIEW	01-19-17
ISSUE 4	4TH PLAN REVIEW	04-04-17
ISSUE 5	5TH PLAN REVIEW	06-30-17

**NOT FOR CONSTRUCTION**



PROJECT NUMBER:  
DRAWN: MM  
CHECK: MNO  
DATE: 04-04-17  
SCALE:



PLANTING NOTES

**L0.3-A**



# GATES + ASSOCIATES

LANDSCAPE ARCHITECTURE  
LAND PLANNING • URBAN DESIGN  
2671 CROW CANYON RD. SAN RAMON, CA 94583  
T 925.734.8176 www.gates.com

## DNS APARTMENTS

HAYWARD  
CALIFORNIA

ISSUE	DESCRIPTION	DATE
ISSUE 1	PLAN REVIEW	04-21-16
ISSUE 2	2ND PLAN REVIEW	10-03-16
ISSUE 3	3RD PLAN REVIEW	01-19-17
ISSUE 4	4TH PLAN REVIEW	04-04-17
ISSUE 5	5TH PLAN REVIEW	06-30-17

NOT FOR CONSTRUCTION

*David L. Gates*  
6/9/10/17  
X/XX/XXXX

PROJECT NUMBER:  
DRAWN: MM  
CHECK: MNO  
DATE: 04-04-17  
SCALE:



HYDROZONE PLAN

# L0.4-A

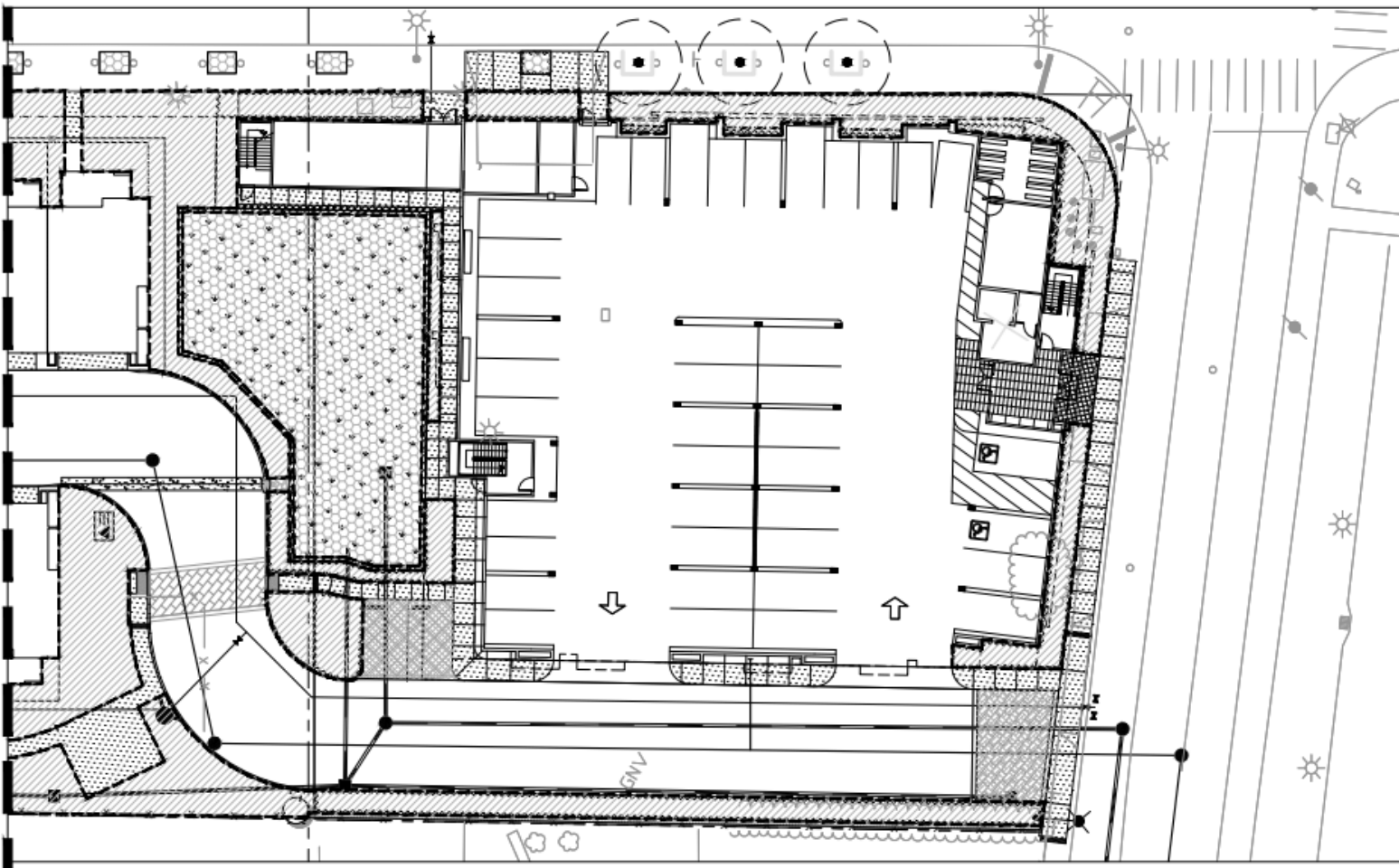
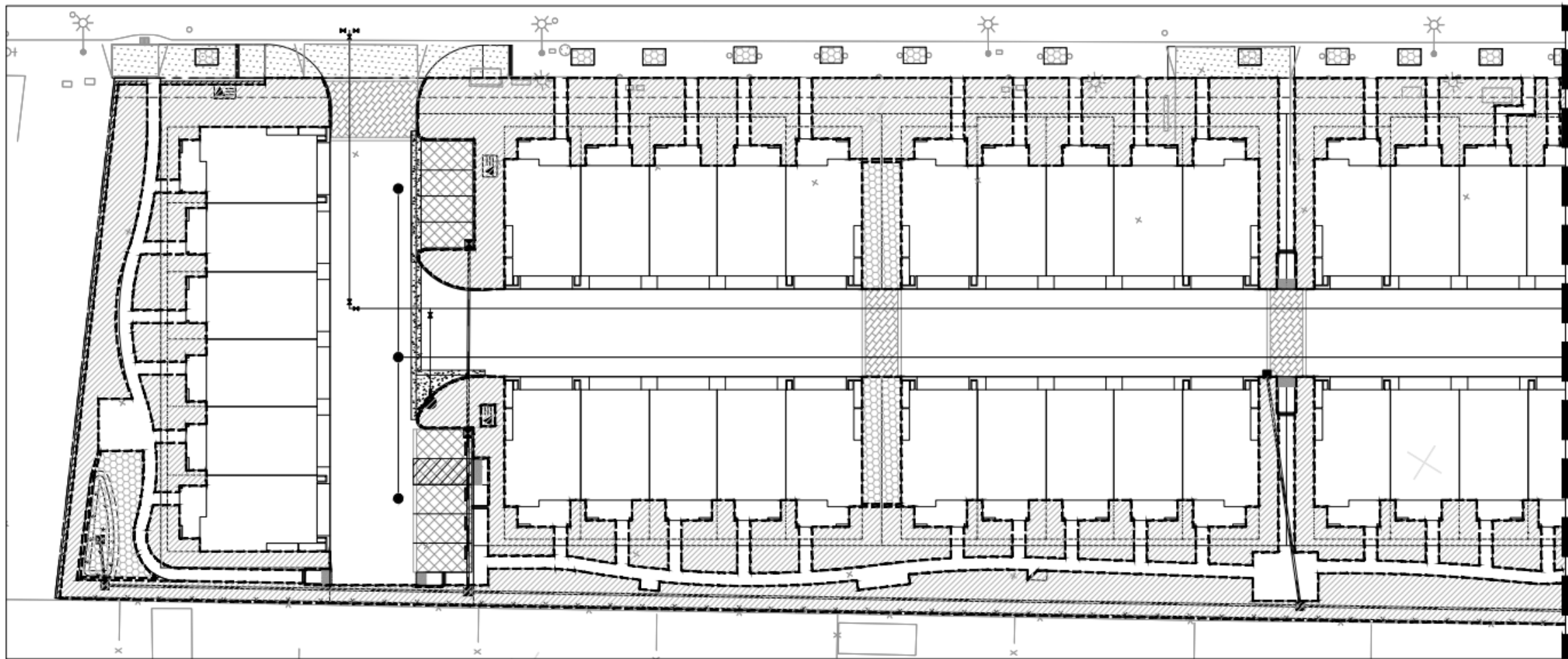

### HYDROZONE LEGEND

A	LOW WATER USE	29,796 SF	88%
B	MODERATE WATER USE	4,199 SF	12%
TOTAL PLANTING AREA		33,995 SF	100%

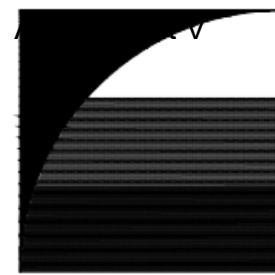

**GATES + ASSOCIATES**  
 LANDSCAPE ARCHITECTURE  
 LAND PLANNING • URBAN DESIGN  
 2671 CROW CANYON RD. SAN RAMON, CA 94583  
 T 925-734-8176 www.gates.com

**DNS APARTMENTS**  
 HAYWARD CALIFORNIA

ISSUE	DESCRIPTION	DATE
ISSUE 1	PLAN REVIEW	04-21-16
ISSUE 2	2ND PLAN REVIEW	10-03-16
ISSUE 3	3RD PLAN REVIEW	01-19-17
ISSUE 4	4TH PLAN REVIEW	04-04-17
ISSUE 5	5TH PLAN REVIEW	06-30-17

**NOT FOR CONSTRUCTION**



PROJECT NUMBER:  
 DRAWN: MM  
 CHECK: MNO  
 DATE: 04-04-17  
 SCALE: 1" = 10'-0"



LAYOUT PLAN

**L1.1-A**

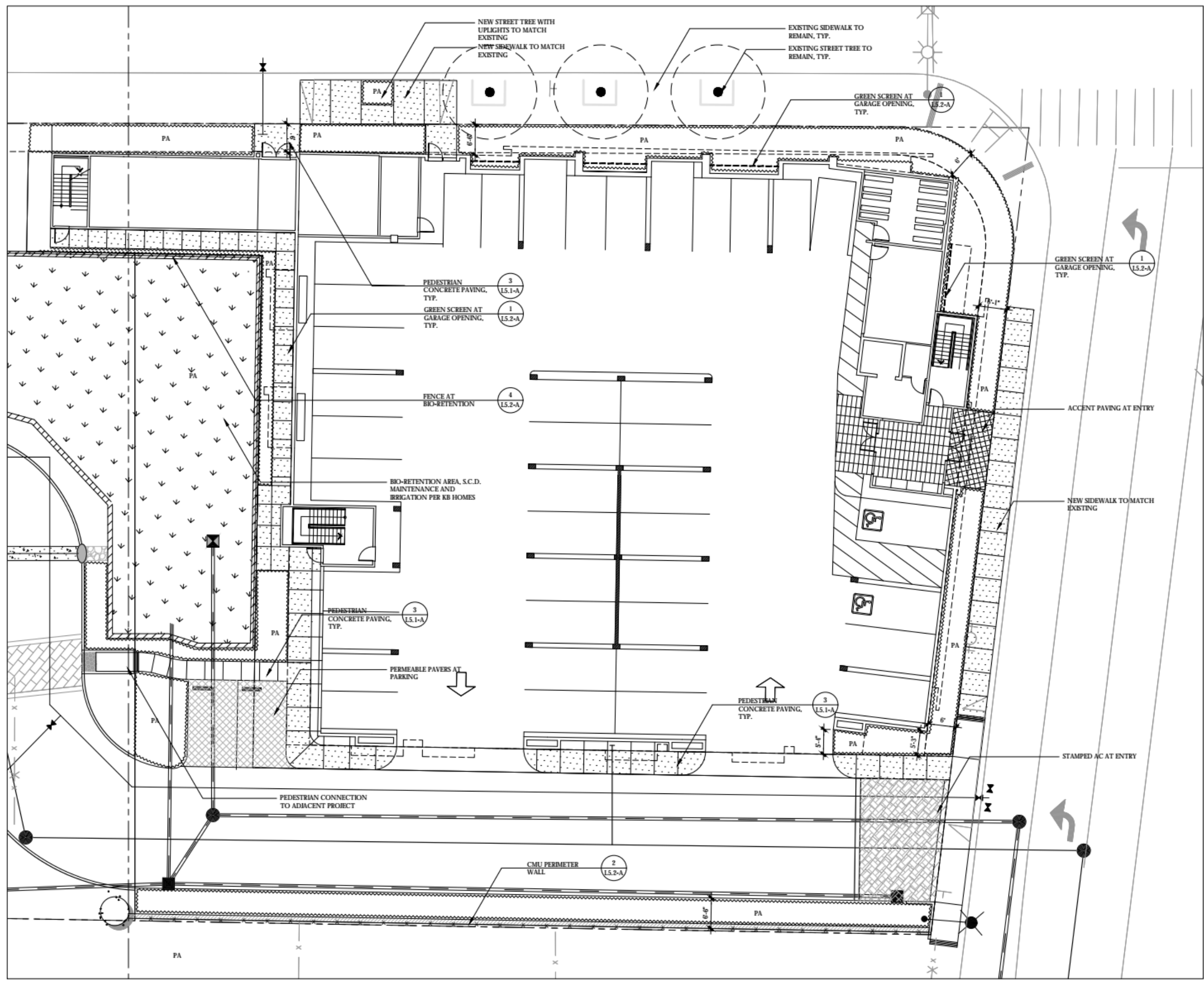

P:\16-PHAYWAY\ADDONS\APARTMENTS\TMC\03\LDG-4 DNS APARTMENTS.DWG  
 PLOT DATE: 02/08/17 6:08 PM



# GATES + ASSOCIATES

LANDSCAPE ARCHITECTURE  
LAND PLANNING • URBAN DESIGN

2671 CROW CANYON RD. SAN RAMON, CA 94583  
T 925.734.8176 www.gates.com

## DNS APARTMENTS

HAYWARD  
CALIFORNIA

ISSUE	DESCRIPTION	DATE
ISSUE 1	PLAN REVIEW	04-21-16
ISSUE 2	2ND PLAN REVIEW	10-03-16
ISSUE 3	3RD PLAN REVIEW	01-19-17
ISSUE 4	4TH PLAN REVIEW	04-04-17
ISSUE 5	5TH PLAN REVIEW	06-30-17

**NOT FOR CONSTRUCTION**



PROJECT NUMBER:  
DRAWN: MM  
CHECK: MNO  
DATE: 04-04-17  
SCALE:



### PLANTING PLAN

# L2.1-A

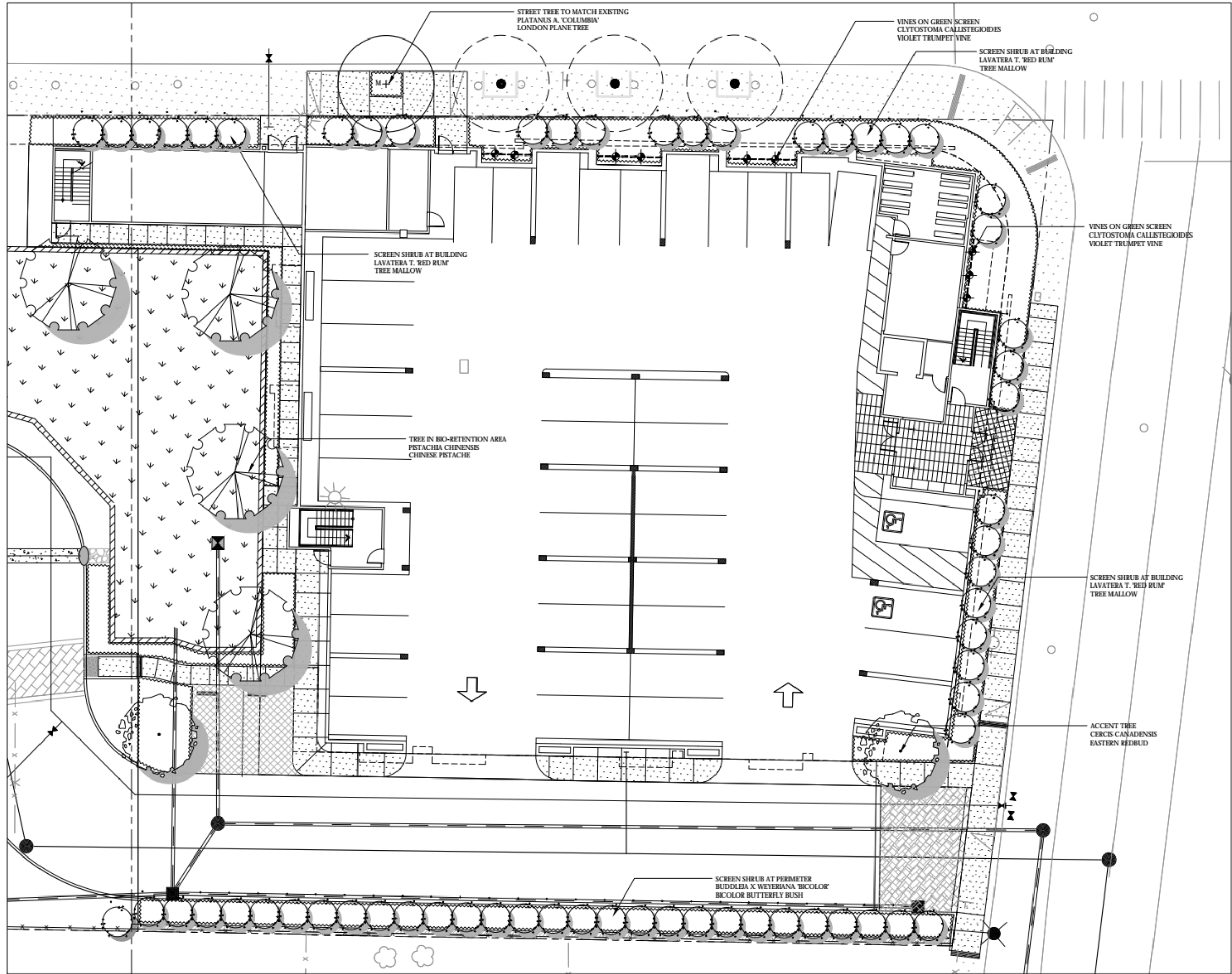

PATRICIA WARDEN, ARCHITECT/TMCA/01/04/07 DNS APARTMENTS.DWG  
PLOT DATE: 02/08/17 8:17 PM

P:\16-PHASE\16-DNS\16-DNS APARTMENTS\16-DNS APARTMENTS.DWG  
PLOT DATE: 02/01/17 6:17 PM

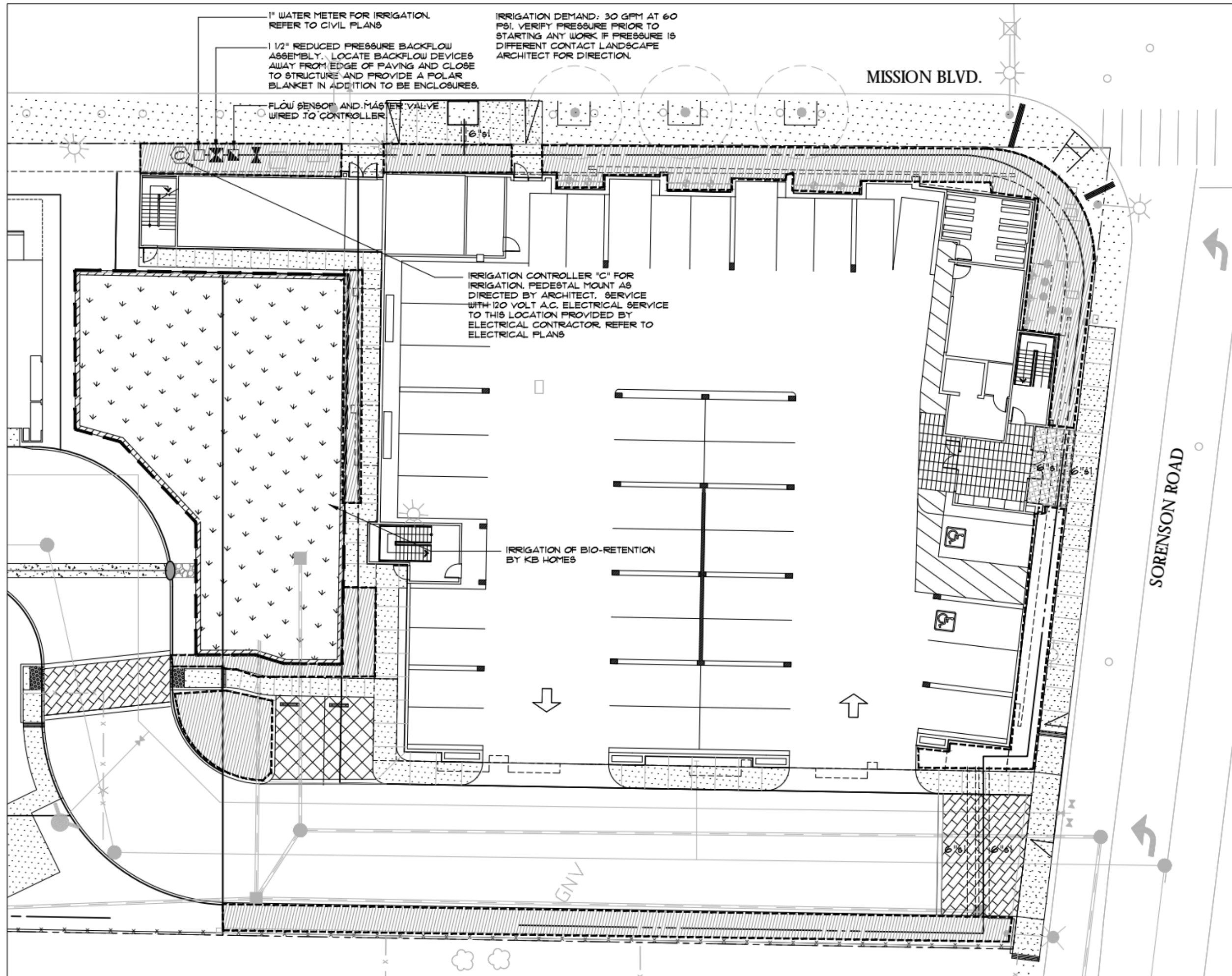

**GATES**  
+ASSOCIATES  
LANDSCAPE ARCHITECTURE  
LAND PLANNING • URBAN DESIGN  
2671 CROW CANYON RD. SAN RAMON, CA 94583  
T 925.734.8176 www.gates.com

**DNS**  
**APARTMENTS**

HAYWARD  
CALIFORNIA

ISSUE	DESCRIPTION	DATE
ISSUE 1	PLAN REVIEW	04-21-16
ISSUE 2	2ND PLAN REVIEW	10-03-16
ISSUE 3	3RD PLAN REVIEW	01-19-17
ISSUE 4	4TH PLAN REVIEW	04-04-17
ISSUE 5	5TH PLAN REVIEW	06-30-17

**NOT FOR  
CONSTRUCTION**



PROJECT NUMBER:  
DRAWN: MM  
CHECK: MNO  
DATE: 04-04-17  
SCALE: 1" = 20'-0"



IRRIGATION PLAN

**L3.1-A**



**IRRIGATION NOTES**

- THIS DESIGN IS DIAGRAMMATIC. ALL PIPING, VALVES, ETC. SHOWN WITHIN PAVED AREAS IS FOR DESIGN CLARIFICATION ONLY AND SHALL BE INSTALLED IN PLANTING AREAS WHERE POSSIBLE. AVOID ANY CONFLICTS BETWEEN THE SPRINKLER SYSTEM, PLANTING AND ARCHITECTURAL FEATURES.
- DO NOT WILLFULLY INSTALL THE SPRINKLER SYSTEM AS SHOWN ON THE DRAWINGS WHEN IT IS OBVIOUS IN THE FIELD THAT OBSTRUCTIONS, GRADE DIFFERENCES OR DIFFERENCES IN THE AREA DIMENSIONS EXIST THAT MIGHT NOT HAVE BEEN CONSIDERED IN THE ENGINEERING. SUCH OBSTRUCTIONS OR DIFFERENCES SHOULD BE BROUGHT TO THE ATTENTION OF THE OWNER'S AUTHORIZED REPRESENTATIVE. IN THE EVENT THAT THIS NOTIFICATION IS NOT PERFORMED, THE IRRIGATION CONTRACTOR SHALL ASSUME FULL RESPONSIBILITY FOR ANY REVISIONS NECESSARY.
- IT IS THE RESPONSIBILITY OF THE IRRIGATION CONTRACTOR TO FAMILIARIZE HIMSELF WITH ALL GRADE DIFFERENCES, LOCATION OF WALLS, RETAINING WALLS, ETC. HE SHALL COORDINATE HIS WORK WITH THE GENERAL CONTRACTOR AND OTHER SUBCONTRACTORS FOR THE LOCATION AND THE INSTALLATION OF PIPE SLEEVES THROUGH WALLS, UNDER ROADWAYS, PAVING, STRUCTURES, ETC.
- DUE TO THE SCALE OF THE DRAWINGS, IT IS NOT POSSIBLE TO INDICATE ALL OFFSETS, FITTINGS, SLEEVES, ETC., WHICH MAY BE REQUIRED. THE CONTRACTOR SHALL CAREFULLY INVESTIGATE THE STRUCTURAL AND FINISHED CONDITIONS AFFECTING ALL OF HIS WORK AND PLAN HIS WORK ACCORDINGLY, FURNISHING SUCH FITTINGS, ETC., AS MAY BE REQUIRED TO MEET SUCH CONDITIONS. DRAWINGS ARE GENERALLY DIAGRAMMATIC AND INDICATIVE OF THE WORK TO BE INSTALLED. THEN WORK SHALL BE INSTALLED IN SUCH A MANNER AS TO AVOID CONFLICTS BETWEEN IRRIGATION SYSTEMS, PLANTING, AND ARCHITECTURAL FEATURES.
- ELECTRICAL CONTRACTOR TO SUPPLY 120 VOLT A.C. (2.5 AMP) SERVICE TO CONTROLLER LOCATION. IRRIGATION CONTRACTOR TO MAKE FINAL CONNECTION FROM ELECTRICAL STUB-OUT TO CONTROLLER.
- EACH CONTROLLER SHALL HAVE ITS OWN INDEPENDENT GROUND WIRE.
- VALVE LOCATIONS SHOWN ARE DIAGRAMMATIC. INSTALL IN GROUND COVER/SHRUB AREAS WHERE POSSIBLE (NOT IN LAWN AREA).
- SPLICING OF 24 VOLT WIRES WILL NOT BE PERMITTED EXCEPT IN VALVE BOXES. LEAVE A 24" COIL OF EXCESS WIRE AT EACH SPLICE AND 100 FEET ON CENTER ALONG WIRE RUN. TAPE WIRE IN BUNDLES 10 FEET ON CENTER. NO TAPING PERMITTED INSIDE SLEEVES.
- INSTALL FOUR (4) SPARE CONTROL WIRES ALONG THE ENTIRE MAIN LINE. LOOP 36" EXCESS WIRE INTO EACH SINGLE VALVE BOX AND INTO ONE VALVE BOX IN EACH GROUP OF VALVES. SPARE WIRES SHALL BE YELLOW, COMMON WIRES SHALL BE WHITE AND CONTROL WIRES SHALL BE RED.
- THE IRRIGATION CONTRACTOR SHALL FLUSH AND ADJUST ALL DRIP TUBES FOR OPTIMUM PERFORMANCE.
- NOTIFY ARCHITECT OF ANY ASPECTS OF LAYOUT WHICH WILL PROVIDE INCOMPLETE OR INSUFFICIENT WATER COVERAGE OF PLANT MATERIAL AND DO NOT PROCEED UNTIL HIS INSTRUCTIONS ARE OBTAINED.
- ALL SPRINKLER HEADS SHALL BE SET PERPENDICULAR TO FINISH GRADE OF THE AREA TO BE IRRIGATED UNLESS OTHERWISE DESIGNATED ON THE PLANS.
- INSTALL A VALCON 5000 SERIES SPRING LOADED CHECK VALVE BELOW DRIP BUBBLERS WHERE LOW HEAD DRAINAGE WILL CAUSE EROSION AND EXCESS WATER.
- INSTALL VALVE BOXES 12" FROM AND PERPENDICULAR TO WALK, CURB, BUILDING OR LANDSCAPE FEATURE. AT MULTIPLE VALVE BOX GROUPS, EACH BOX SHALL BE AN EQUAL DISTANCE FROM THE WALK, CURB, ETC. AND EACH BOX SHALL BE 12" APART. SHORT SIDE OF VALVE BOX SHALL BE PARALLEL TO WALK, CURB LAWN, ETC.
- THE SPRINKLER SYSTEM DESIGN IS BASED ON THE MINIMUM OPERATING PRESSURE SHOWN ON THE IRRIGATION DRAWINGS. THE IRRIGATION CONTRACTOR SHALL VERIFY WATER PRESSURE PRIOR TO CONSTRUCTION. REPORT ANY DIFFERENCE BETWEEN THE WATER PRESSURE INDICATED ON THE DRAWINGS AND THE ACTUAL PRESSURE READING AT THE IRRIGATION POINT OF CONNECTION TO THE OWNER'S AUTHORIZED REPRESENTATIVE.
- OPERATE IRRIGATION CONTROLLER(S) BETWEEN THE HOURS OF 10:00 PM AND 7:00 AM.
- IRRIGATION CONTRACTOR TO NOTIFY ALL LOCAL JURISDICTIONS FOR INSPECTION AND TESTING OF INSTALLED BACKFLOW PREVENTION DEVICE.
- PRIOR TO TRENCHING, CALL UNDERGROUND SERVICE ALERT, (1-800) 642-2444 FOR NORTHERN CALIFORNIA
- WHEN VERTICAL OBSTRUCTIONS (STREET LIGHTS, TREES, FIRE HYDRANTS, ETC.) INTERFERE WITH THE PATTERN OF THE DRIP TUBING LAYOUT SO AS TO PREVENT PROPER COVERAGE, THE IRRIGATION CONTRACTOR SHALL FIELD ADJUST THE DRIP SYSTEM AT THE LOCATION OF THE OBSTRUCTION SO AS TO PROVIDE PROPER COVERAGE. ALL ADJUSTMENTS SHALL BE MADE AT NO ADDITIONAL COST TO THE OWNER.
- TREES WITH DIFFERENT WATERING REQUIREMENTS SHALL BE IRRIGATED ON SEPARATE VALVES.

**IRRIGATION LEGEND**

SYMBOL	MODEL NUMBER	DESCRIPTION	PSI	GPM	RADIUS
●	1401	RAINBIRD FLOOD BUBBLER	30	.25	
■	RWS-B-C-1401	TREE BUBBLERS IN TURF-- TWO RAINBIRD BUBBLER IN DEEP WATERING TUBE PER TREE	30	.25	
▲	OCT856	PEPCO OCTA BUBBLER--SHRUBS	30	6 GPH PER OUTLET	
■	5633	PEPCO QUADRA BUBBLER--SHRUBS	30	6 GPH PER OUTLET	
▷	M64/AP100	SPEARS FLUSHING END PLUG - LOCATE AT END OF LONG DRIP LINES			
⊙	P-220-27	TORO REMOTE CONTROL VALVE			
✂	T-113-K	NIBCO GATE VALVE (LINE SIZE) WITH CROSS HANDLE INSIDE ROUND VALVE BOX			
◆	33-DLRC	RAIN BIRD 3/4" QUICK COUPLING VALVE			
⊠	825Y-BV-SBBC-30SS	FEBCO BACKFLOW PREVENTOR WITH STRONG BOX ENCLOSURE TO BE INSTALLED PER CITY OF HAYWARD STANDARD DETAIL #202 SHEET L3.7			
⊠	1-1201-1151-8130 PMR-MF-30-1"	AMIAD 1" FILTER WITH 130 MESH SCREEN WITH SENNINGER 1" IN-LINE PRESSURE REDUCING VALVE (1-22 GPM)			
⊠	FS150P 3100-1.5"	RAINBIRD FLOW SENSOR WITH SUPERIOR NORMALLY OPEN MASTER VALVE			
⊠	ESP12LXME ESPLXMSM12 (X3) ETC-LX LXMPED RSD-BE	RAINBIRD ET BASED CONTROLLER MOUNTED INSIDE RAINBIRD METAL PEDESTAL ENCLOSURE WITH ET DATA CARD AND WIRED RAIN SENSOR. CONTROLLER IS 48 STATION CAPACITY - 12 STATION BASE CONTROLLER PLUS THREE (3) 12 STATION MODULES ADDED TO CONTROLLER.			
		IRRIGATION INSIDE DASHED OUTLINE AREA: TORO DL2000 DRIPLINE DRIP EMITTER TUBING PART NUMBER: RGP-412-10 - 1.0 GPH EMITTERS 12" ON CENTER DRIPLINE PIPE WITH TORO LOC-EZE FITTINGS (OR EQUAL) INSTALLED 4" COVER BELOW SOIL LEVEL AND 8" FROM EDGE OF SIDEWALK OR CURB. INSTALL DRIPLINE PER INSTALLATION DETAILS SHEET L-8			
		STATION NUMBER GALLONS PER MINUTE VALVE SIZE			
		MAINLINE: SCHEDULE 40 PVC PLASTIC PIPE WITH SCHEDULE 40 PVC SOLVENT WELD FITTINGS. 18" COVER.			
		LATERAL LINE: 1120-CLASS 200 PVC PLASTIC PIPE WITH SCHEDULE 40 PVC SOLVENT WELD FITTINGS. 12" COVER.			
		SLEEVE: 1120-200 PSI PVC PLASTIC PIPE W/SCHEDULE 40 PVC PLASTIC FITTINGS. 24" COVER. SIZE NOTED ON PLANS.			

Water calculation worksheet for the Model Water Efficient Landscape Ordinance AB 1881

Item	Value	Item	Value	Item	Value	Item	Value	Item	Value
Total Landscape Area (sf)	31,470	KL	Landscape Coefficient	Eto	Referenced Evapotranspiration Rate				
Special Landscape Area (SLA)	0	Ks	Species Factor	ETAF	ET Adjustment factor				
Historical Eto for project city	44.2	Kd	Density Factor	LA	Total Landscape area				
Turf Rotor Efficiency	0.75	Kmc	Microclimate Factor	0.62	Conversion factor to gallons				
Flood bubbler Irrigation Efficiency	0.81	IE	Irrigation Efficiency	SLA	Special Landscape Area				
Spray irrigation Efficiency	0.75								
Drip Irrigation Efficiency	0.81	MAWA = (Eto)0.62/((0.55 x LA + 0.45 x SLA)							
Stream Spray Efficiency	0.75	ETWU = (Eto)0.62/((PFxHA / IE) + SLA)							
<b>Maximum Applied Water Use (MAWA)</b>									
	Eto	Conversion	ETAF	LA	(1-ETAF)	SLA			Gallons per year
Total landscape area	44.2	0.62	0.55	31,470	0.45	0			474,322
<b>MAXIMUM APPLIED WATER ALLOWANCE</b>									
									474,322
<b>Estimated Total Water Use (ETWU)</b>									
Hydrozone & Irrigation method	Area (sf)	Eto	Ks	Kd	Kmc	KL	IE	Conversion	Gallons per year
Trees	24,730	44.2	0.4	1	1	0.4	0.81	0.62	334,667
DNS Apartments	6,740	44.2	0.4	1	1	0.4	0.81	0.62	91,211
<b>Total area</b>									
	31,470								
<b>TOTAL WATER APPLIED</b>									
									425,878
<b>Difference between MAWA &amp; ETWU</b>									
									48,444
<b>% ETWU is under MAWA</b>									
									10.2%

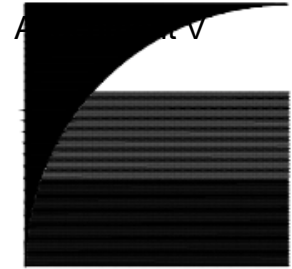

**GATES + ASSOCIATES**  
 LANDSCAPE ARCHITECTURE  
 LAND PLANNING + URBAN DESIGN  
 2671 CROW CANYON RD. SAN RAMON, CA 94583  
 T 925.736.8176 www.gates.com

**DNS APARTMENTS**

HAYWARD CALIFORNIA

ISSUE	DESCRIPTION	DATE
ISSUE 1	PLAN REVIEW	04-21-16
ISSUE 2	2ND PLAN REVIEW	10-03-16
ISSUE 3	3RD PLAN REVIEW	01-19-17
ISSUE 4	4TH PLAN REVIEW	04-04-17
ISSUE 5	5TH PLAN REVIEW	06-30-17

**NOT FOR CONSTRUCTION**



PROJECT NUMBER:  
 DRAWN: MM  
 CHECK: MNO  
 DATE: 04-04-17  
 SCALE:



**IRRIGATION DETAILS**

**L3.2-A**



**GATES + ASSOCIATES**  
 LANDSCAPE ARCHITECTURE  
 LAND PLANNING • URBAN DESIGN  
 2571 CROW CANYON RD. SAN RAMON, CA 94583  
 T 925.736.8176 www.gates.com

**DNS APARTMENTS**

HAYWARD CALIFORNIA

ISSUE	DESCRIPTION	DATE
ISSUE 1	PLAN REVIEW	04-21-16
ISSUE 2	2ND PLAN REVIEW	10-03-16
ISSUE 3	3RD PLAN REVIEW	01-19-17
ISSUE 4	4TH PLAN REVIEW	04-04-17
ISSUE 5	5TH PLAN REVIEW	06-30-17

**NOT FOR CONSTRUCTION**



PROJECT NUMBER:  
 DRAWN: MM  
 CHECK: MNO  
 DATE: 04-04-17  
 SCALE:



**IRRIGATION DETAILS**

**L3.3-A**

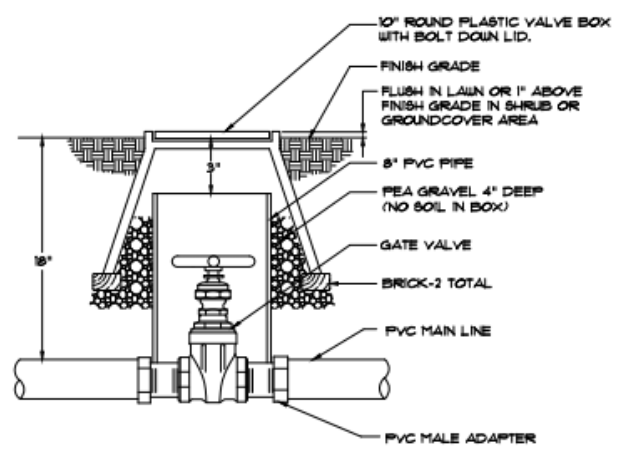

1 GATE VALVE INSTALLATION  
 NTS

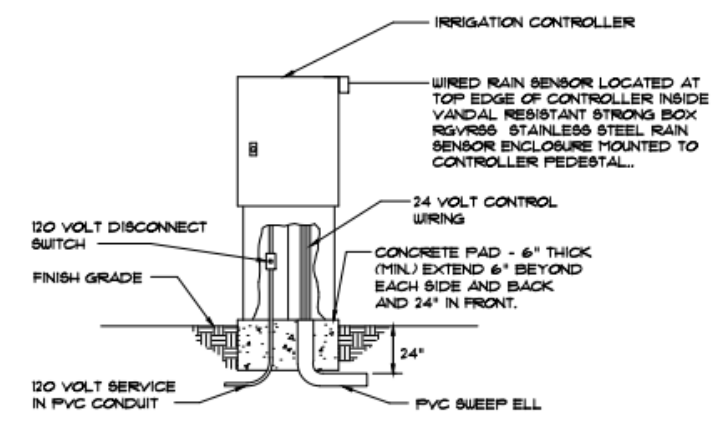

2 PEDESTAL MOUNT CONTROLLER  
 NTS

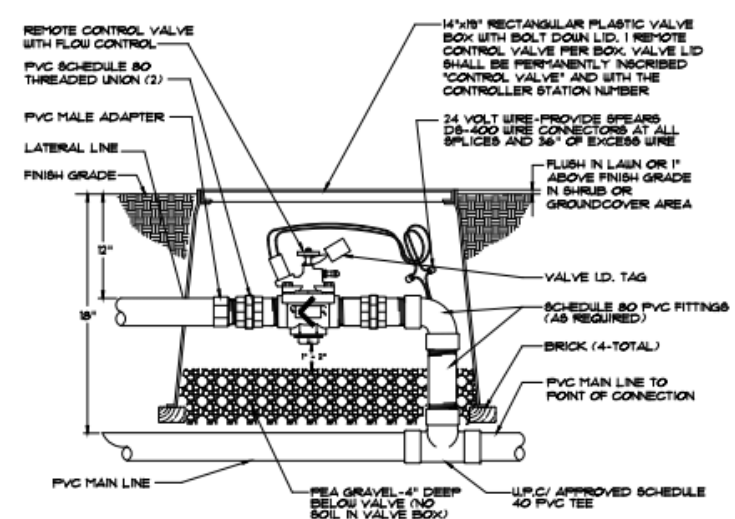

3 REMOTE CONTROL VALVE INSTALLATION  
 NTS

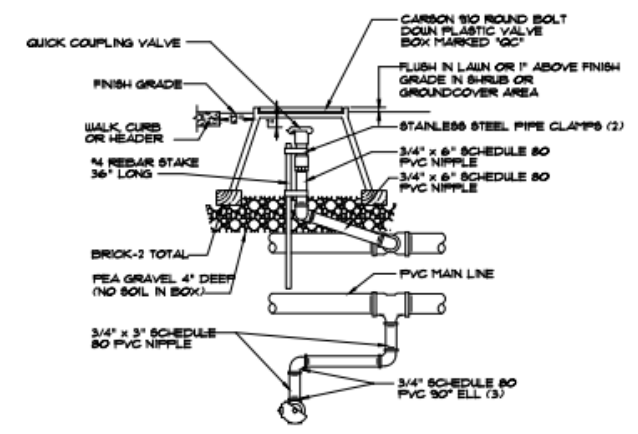

4 3/4" QUICK COUPLER IN BOX  
 NTS

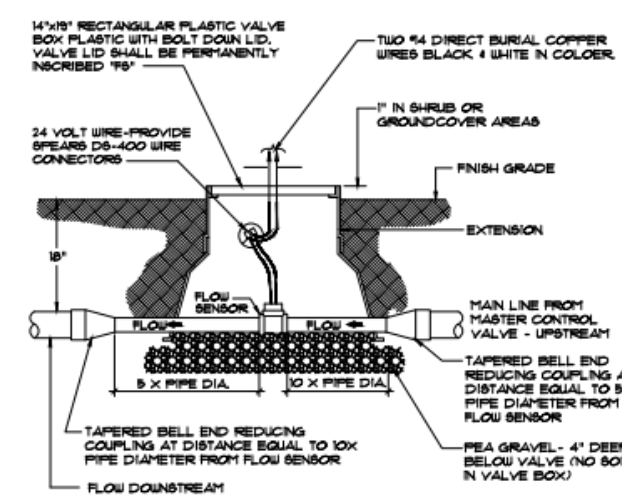

5 FLOW SENSOR INSTALLATION  
 NTS

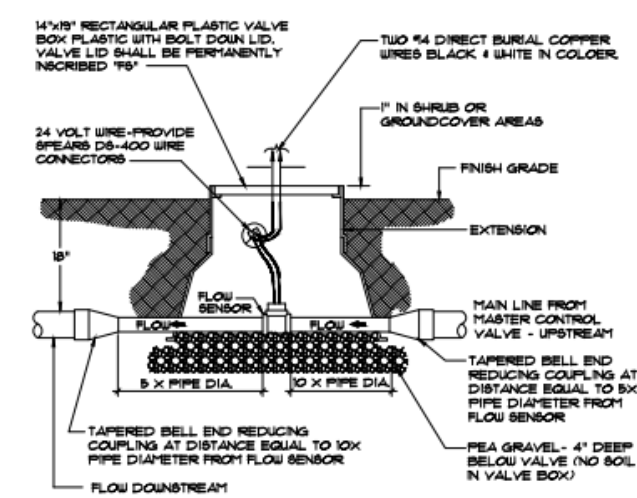

6 FLOW SENSOR INSTALLATION  
 NTS

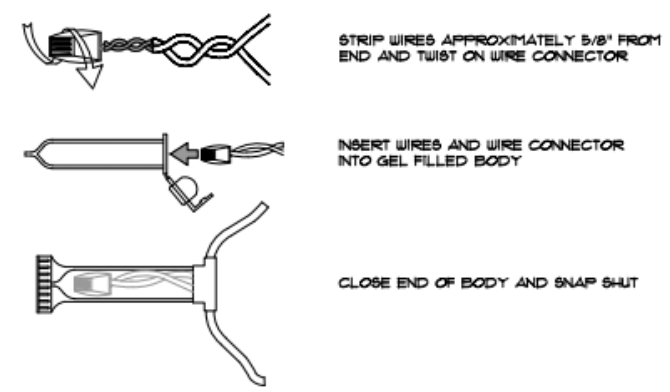

7 DBRY20 WIRE CONNECTION  
 NTS

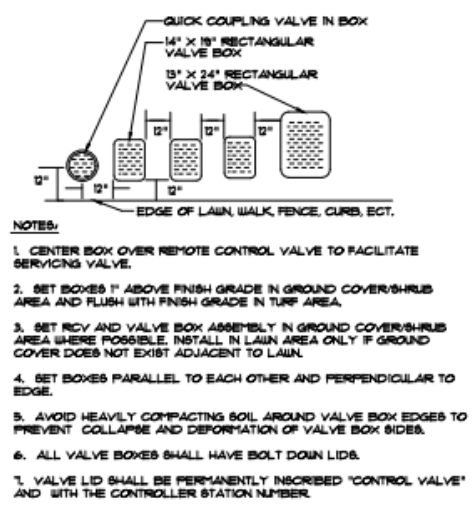

8 VALVE BOX INSTALLATION  
 NTS

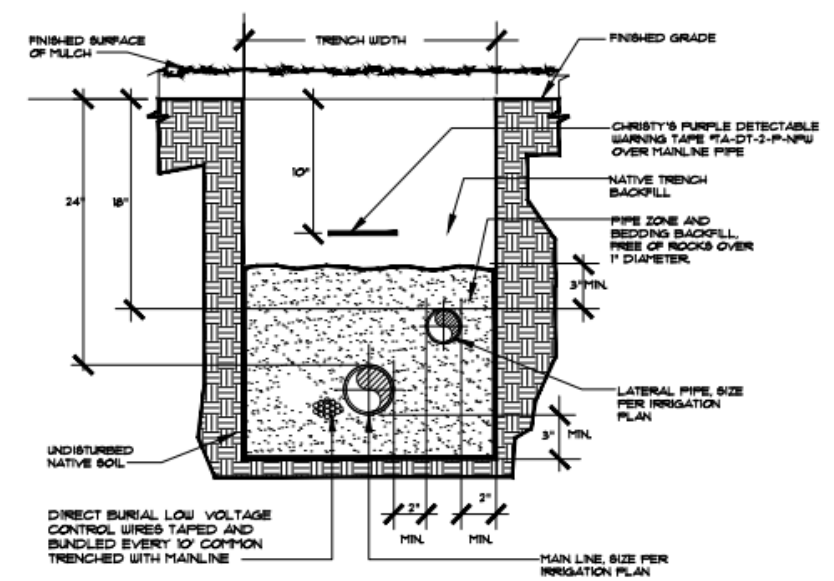

9 TYPICAL COMBINATION TRENCH  
 NTS

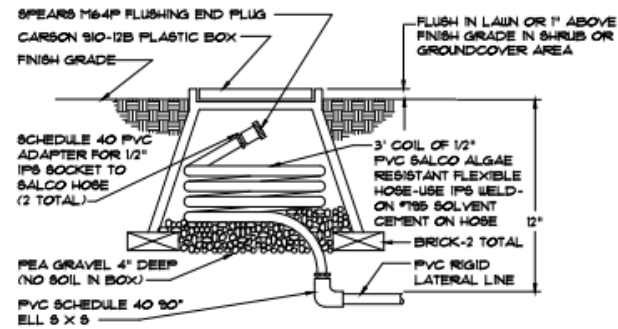

10 FLUSHING END PLUG INSTALLATION  
NTS

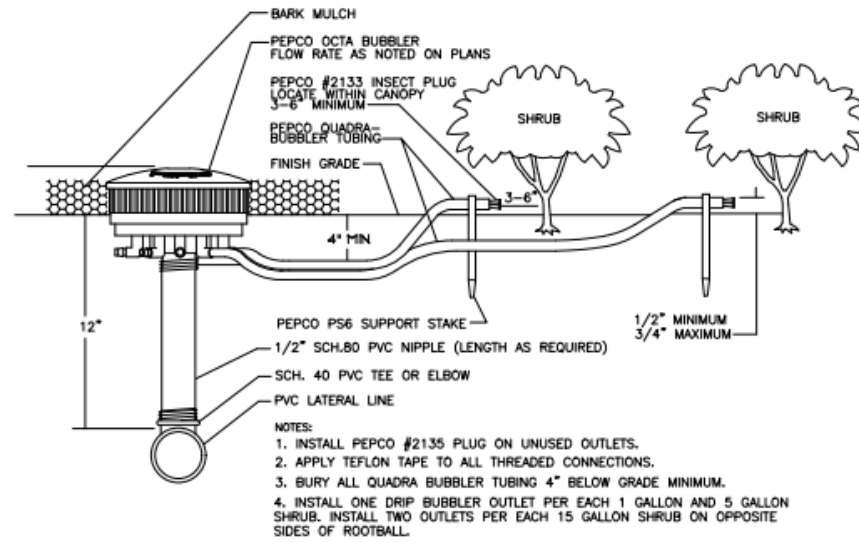

11 OCTA-BUBBLER DETAIL  
NTS

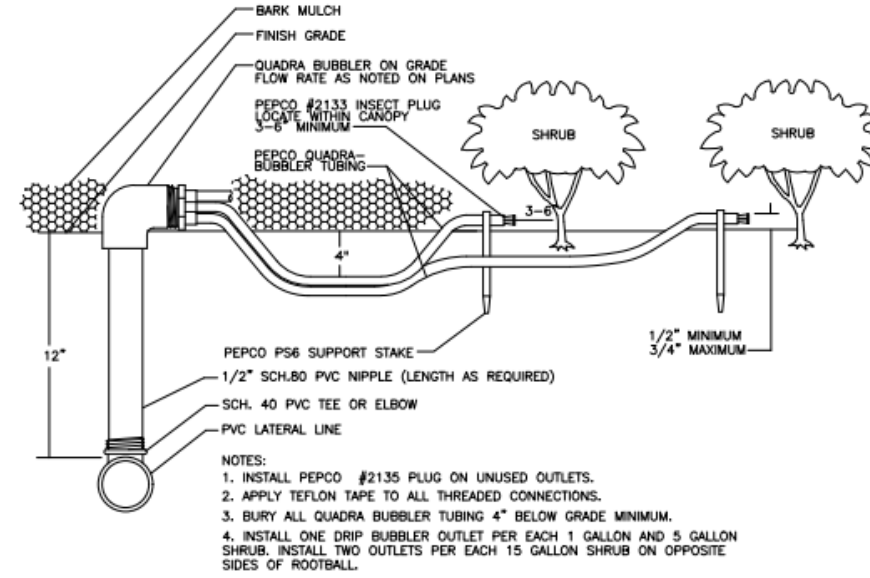

12 DRIP BUBBLER INSTALLATION  
NTS

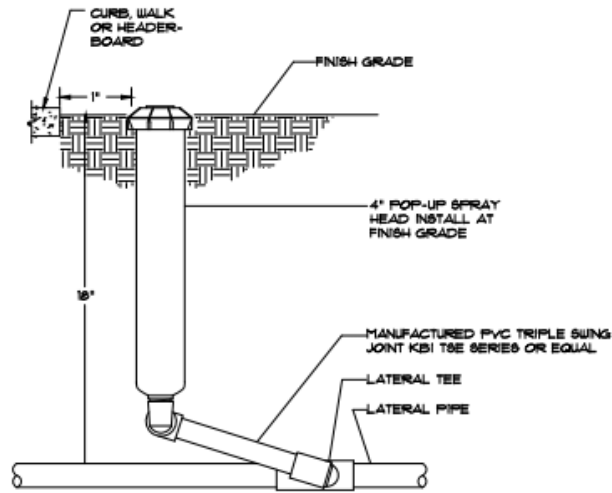

13 POP-UP 4" SPRAY HEAD INSTALLATION  
NTS

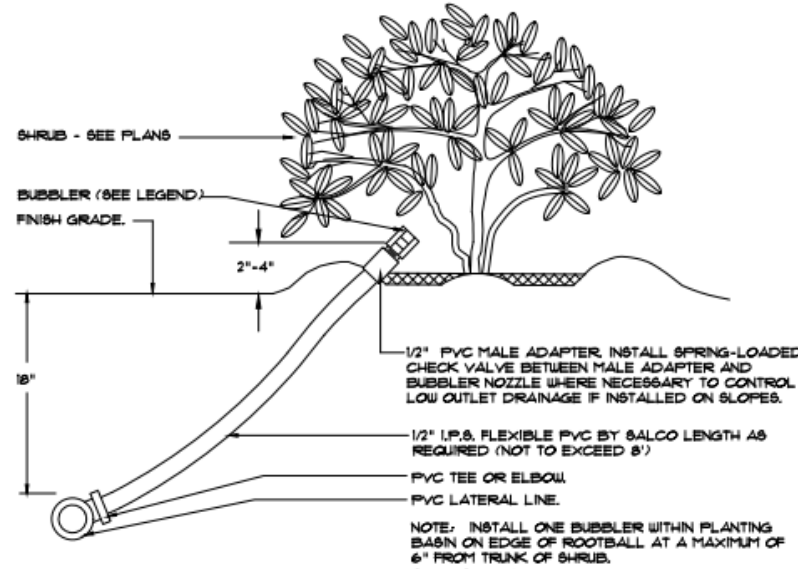

14 SHRUB BUBBLER INSTALLATION  
NTS

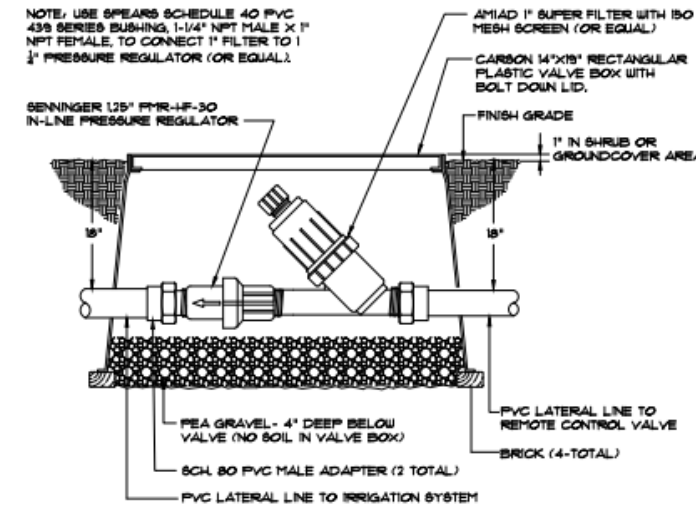

15 FILTER AND PRESSURE REGULATOR  
NTS

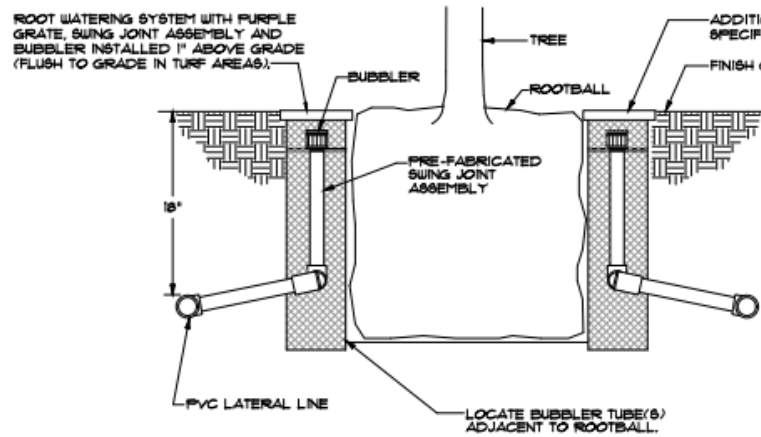

16 TREE BUBBLER INSTALLATION  
NTS

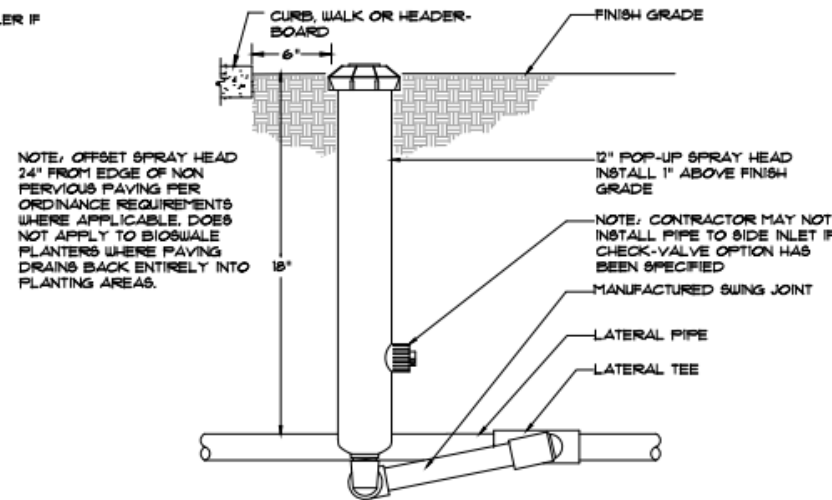

17 SPRAY HEAD INSTALLATION  
NTS

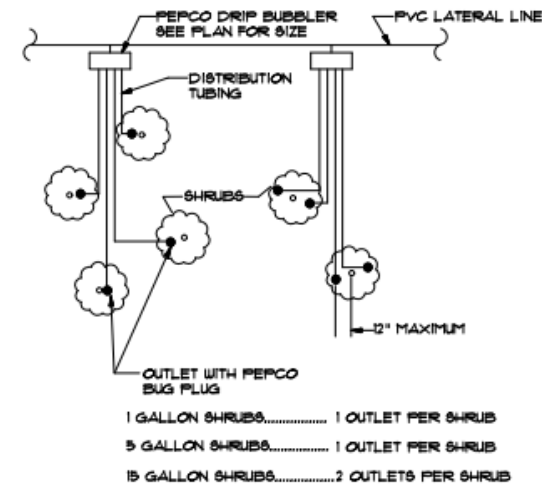

18 TYPICAL DRIP BUBBLER LAYOUT  
NTS

**GATES**  
**+ASSOCIATES**  
LANDSCAPE ARCHITECTURE  
LAND PLANNING • URBAN DESIGN  
2671 CROW CANYON RD. SAN RAMON, CA 94583  
7 925.734.8176 www.gates.com

**DNS**  
**APARTMENTS**

HAYWARD  
CALIFORNIA

ISSUE	DESCRIPTION	DATE
ISSUE 1	PLAN REVIEW	04-21-16
ISSUE 2	2ND PLAN REVIEW	10-03-16
ISSUE 3	3RD PLAN REVIEW	01-19-17
ISSUE 4	4TH PLAN REVIEW	04-04-17
ISSUE 5	5TH PLAN REVIEW	06-30-17

**NOT FOR CONSTRUCTION**



PROJECT NUMBER:	
DRAWN:	MM
CHECK:	MNO
DATE:	04-04-17
SCALE:	



IRRIGATION DETAILS

**L3.4-A**



**GATES + ASSOCIATES**  
 LANDSCAPE ARCHITECTURE  
 LAND PLANNING • URBAN DESIGN  
 2671 CROW CANYON RD. SAN RAMON, CA 94583  
 T 925.736.8176 www.gates.com

**DNS APARTMENTS**

HAYWARD CALIFORNIA

ISSUE	DESCRIPTION	DATE
ISSUE 1	PLAN REVIEW	04-21-16
ISSUE 2	2ND PLAN REVIEW	10-03-16
ISSUE 3	3RD PLAN REVIEW	01-19-17
ISSUE 4	4TH PLAN REVIEW	04-04-17
ISSUE 5	5TH PLAN REVIEW	06-30-17

**NOT FOR CONSTRUCTION**



PROJECT NUMBER:	
DRAWN:	MM
CHECK:	MNO
DATE:	04-04-17
SCALE:	

**IRRIGATION DETAILS**

**L3.5-A**

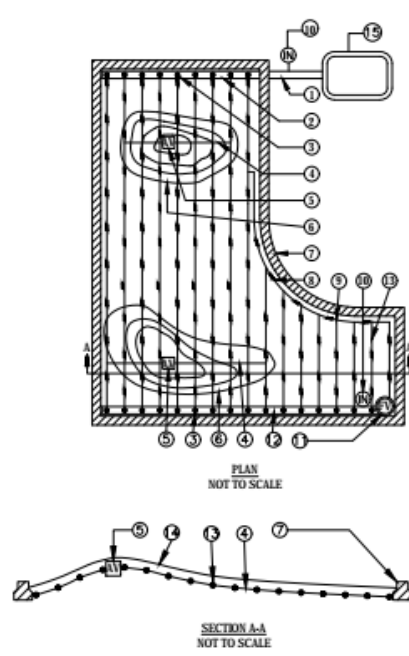

- PVC LATERAL LINE FROM DRIP ZONE KIT.
- PVC SUPPLY MANIFOLD.
- TORO DL2000 MANIFOLD TO ELBOW CONNECTION (TYP).
- AIR/VACUUM RELIEF LATERAL, TORO BLUE STRIPE POLY TUBING (T-EHP1645) CENTERED ON MOUND OR BERM.
- TORO DL2000 AIR/VACUUM RELIEF VALVE (YD-500-34) PLUMBED TO TORO BLUE STRIPE POLY TUBING (T-EHP1645) AT EACH HIGH POINT.
- BERM (TYP).
- EDGE OF PLANTER.
- PERIMETER LATERALS 2" TO 4" FROM EDGE.
- TORO DL2000 TEE (FTT16).
- TORO T-DL-MP9 OPERATION INDICATOR CONNECTED TO LATERAL LINE INSTALLED AT THE EDGE OF THE LANDSCAPE NEAR THE CONTROL VALVE AND AT END OF DRIPLINE ZONE NEAR FLUSH VALVE.
- TORO DL2000 AUTOMATIC FLUSH VALVE PLUMBED TO FLUSH MANIFOLD AT LOW POINT.
- PVC FLUSH MANIFOLD.
- TORO DL2000 DRIPLINE LATERAL.
- FINISHED GRADE.
- REMOTE CONTROL VALVE.

**19 TYPICAL DRIP LAYOUT ON MOUNDS**  
NTS

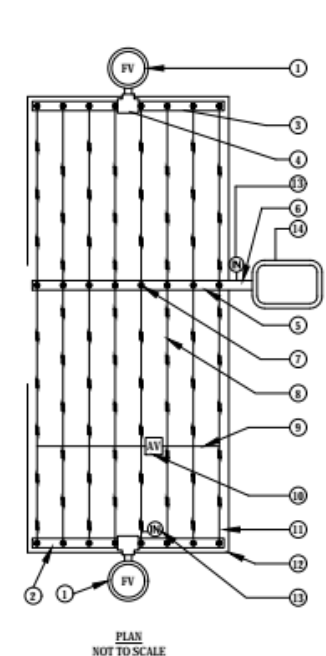

- TORO DL2000 AUTOMATIC FLUSH VALVE PLUMBED TO FLUSH MANIFOLD AT LOW POINT.
- MANIFOLD AT LOW POINT.
- PVC FLUSH MANIFOLD.
- TORO DL2000 MANIFOLD-TO-ELBOW CONNECTION (TYP).
- PVC LATERAL LINE FROM DRIP ZONE KIT.
- PVC SUPPLY MANIFOLD.
- TORO DL2000 MANIFOLD-TO-TEE CONNECTION.
- TORO DL2000 DRIPLINE LATERAL.
- AIR/VACUUM RELIEF LATERAL, TORO BLUE STRIPE POLY TUBING (T-EHP1645) CENTERED ON MOUND OR BERM.
- TORO DL2000 AIR/VACUUM RELIEF VALVE (YD-500-34) PLUMBED TO TORO BLUE STRIPE POLY TUBING AT EACH HIGH POINT.
- PERIMETER LATERALS 2" TO 4" FROM EDGE.
- AREA PERIMETER.
- TORO T-DL-MP9 OPERATION INDICATOR CONNECTED TO LATERAL LINE INSTALLED AT THE EDGE OF THE LANDSCAPE NEAR THE CONTROL VALVE.
- REMOTE CONTROL VALVE.

**20 TYPICAL CENTER FEED DRIP SYSTEM LAYOUT**  
NTS

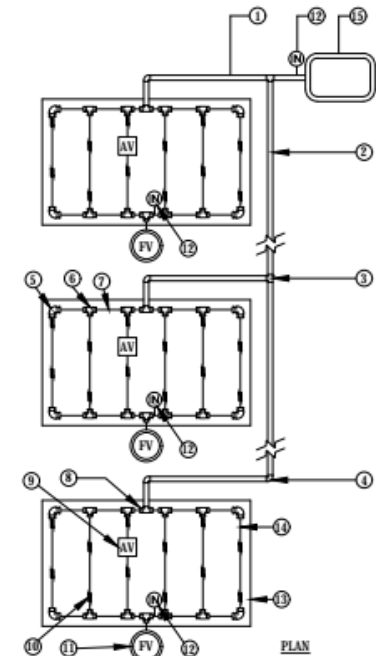

- PVC LATERAL LINE FROM CONTROL VALVE.
- PVC SUPPLY MANIFOLD.
- PVC TEE (SxS).
- PVC ELL (SxS).
- TORO LOC-EZE ELL (FEE16).
- TORO LOC-EZE TEE (FTT16).
- TORO BLUE STRIPE POLY TUBING AT SUPPLY AND FLUSH END OF EACH ISLAND.
- TORO LOC-EZE TEE X 1/2" SLIP ADAPTER (FTV16).
- TORO DL2000 AIR/VACUUM RELIEF VALVE (YD-500-34) PLUMBED TO TUBING AT HIGH POINT.
- TORO DL2000 DRIPLINE LATERAL.
- TORO DL2000 AUTOMATIC FLUSH VALVE PLUMBED TO FLUSH MANIFOLD AT LOW POINT.
- ISLAND PERIMETER.
- PERIMETER LATERALS 2" TO 4" FROM EDGE.
- CONTROL VALVE.

**21 TYPICAL ISLAND MANIFOLD**  
NTS

- ASSEMBLE AND INSTALL FILTER, REMOTES CONTROL VALVE AND PRESSURE REGULATING VALVE ASSEMBLIES ACCORDING TO DETAILS.
- ASSEMBLE AND INSTALL SUPPLY HEADERS ACCORDING TO DETAIL. TAPE OR PLUG OPEN CONNECTIONS TO PREVENT DEBRIS CONTAMINATION.
- ASSEMBLE AND INSTALL EXHAUST HEADERS IN ACCORDANCE WITH DETAILS. TAPE OR PLUG ALL OPEN CONNECTIONS TO PREVENT DEBRIS CONTAMINATION.
- INSTALL DRIP LATERALS. TAPE OR PLUG OPEN ENDS WHILE INSTALLING TO PREVENT DEBRIS CONTAMINATION.
- INSTALL AIR VACUUM RELIEF VALVES AT HIGHEST POINTS OF THE IRRIGATION ZONES IN ACCORDANCE WITH DETAILS.
- THOROUGHLY FLUSH DRIPLINE LATERALS AND CONNECT TO EXHAUST HEADERS OR INTERCONNECTING LATERALS WHILE FLUSHING.
- THOROUGHLY FLUSH EXHAUST HEADERS AND INSTALL LINE FLUSHING VALVES ACCORDING TO DETAILS.
- THOROUGH FLUSHING OF EACH INSTALLATION SEGMENT IS NECESSARY TO ENSURE THAT NO DEBRIS CONTAMINATION OCCURS.
- LOCATE AND INSTALL CHECK VALVE(S) AS NEEDED AND AS SHOWN IN INSTALLATION DETAILS.
- SEE IRRIGATION NOTES, LEGEND/SPECIFICATIONS FOR ADDITIONAL INFORMATION.
- ALL TREES TO BE PLANTED WITHIN CENTER OF DRIP LINE RUNS
- BURY DRIPLINE 4" BELOW GRADE AND STAKE EACH 36" O.C. LOCATED AT EMITTER AND AS NECESSARY TO INSURE SECURITY.
- ALL FITTINGS TO BE USED WILL BE PER MANUFACTURERS SPECIFICATION. COMPRESSION FITTINGS OR APPROVED EQUAL.
- THE TOTAL LENGTH OF ALL INTERCONNECTED DRIP LINE SHALL NOT EXCEED THE MAXIMUM RUN LENGTH. SEE TORO SUBSURFACE IRRIGATION DESIGN GUIDE

**24 SUBSURFACE DRIPLINE INSTALLATION NOTES**  
NTS

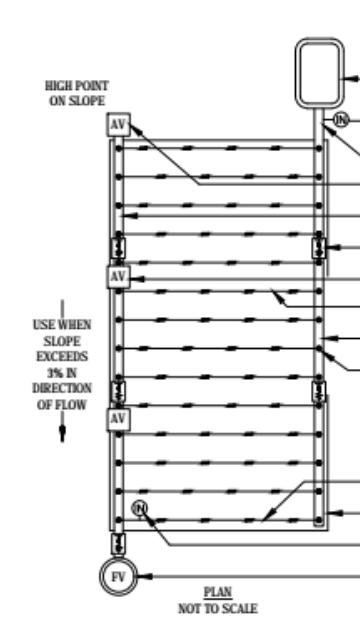

- PVC LATERAL LINE FROM DRIP ZONE KIT.
- TORO DL2000 AIR/VACUUM RELIEF VALVE (YD-500-34) PLUMBED TO PVC FLUSH MANIFOLD AT HIGH POINT.
- PVC FLUSH MANIFOLD.
- INLINE SPRING CHECK VALVE (JV0500-S2) TO HELP CONTROL LOW-HEAD DRAINAGE (TYP).
- TORO DL2000 AIR/VACUUM RELIEF VALVE (YD-500-34) PLUMBED TO PVC FLUSH MANIFOLD JUST BELOW EACH CHECK VALVE (TYP).
- TORO DL2000 DRIPLINE LATERAL.
- PVC SUPPLY MANIFOLD.
- TORO DL2000 MANIFOLD-TO-ELBOW CONNECTION (TYP).
- PERIMETER LATERALS 2" TO 4" FROM EDGE.
- AREA PERIMETER.
- TORO T-DL-MP9 OPERATION INDICATOR CONNECTED TO LATERAL LINE INSTALLED AT THE EDGE OF THE LANDSCAPE NEAR THE CONTROL VALVE AND AT END OF DRIPLINE ZONE NEAR FLUSH VALVE.
- TORO DL2000 AUTOMATIC FLUSH VALVE PLUMBED TO FLUSH MANIFOLD AT LOW POINT.
- REMOTE CONTROL VALVE.

**22 TYPICAL DRIP LAYOUT ON SLOPES**  
NTS

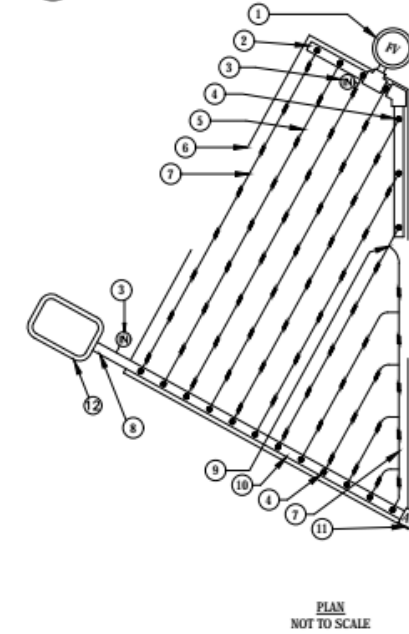

- TORO DL2000 AUTOMATIC FLUSH VALVE PLUMBED TO FLUSH MANIFOLD AT LOW POINT.
- PVC FLUSH MANIFOLD.
- TORO T-DL-MP9 OPERATION INDICATOR CONNECTED TO LATERAL LINE INSTALLED AT THE EDGE OF THE LANDSCAPE NEAR THE CONTROL VALVE AND AT END OF DRIPLINE ZONE NEAR FLUSH VALVE.
- TORO DL2000 MANIFOLD-TO-ELBOW CONNECTION (TYP).
- TORO DL2000 DRIPLINE LATERAL.
- AREA PERIMETER.
- PERIMETER LATERALS 2" TO 4" FROM EDGE.
- PVC LATERAL LINE FROM DRIP ZONE KIT.
- TORO LOC-EZE TEE (FTT16).
- PVC SUPPLY MANIFOLD.
- TORO DL2000 AIR/VACUUM RELIEF VALVE (YD-500-34) PLUMBED TO SUPPLY MANIFOLD AT HIGH POINT.
- REMOTE CONTROL VALVE.

**23 TYPICAL DRIP LAYOUT ON MOUNDS**  
NTS

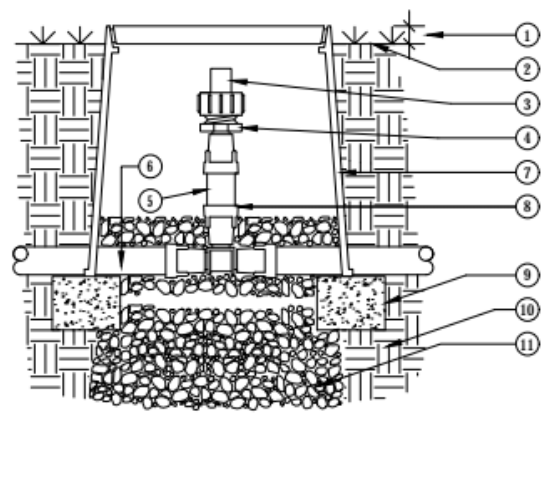

- 1" ABOVE FINISH GRADE.
- FINISH GRADE.
- TORO DL2000 FLUSH VALVE (FCH-H-FHT).
- TORO LOC-EZE X 3/4" MHT ADAPTER (FJA16).
- TORO BLUE STRIPE POLY TUBING.
- PVC PIPING.
- 8" PURPLE LOCKING ROUND PLASTIC VALVE BOX. HEAT BRAND "FV" ON LID IN 1" HIGH CHARACTERS.
- TORO LOC-EZE TEE (TEE16).
- BRICK SUPPORTS (2 COMMON BRICKS REQUIRED).
- NATIVE SOIL PER SPECIFICATIONS.
- PEA GRAVEL SUMP (6" x 18").

**25 FLUSH VALVE INSTALLATION**  
NTS

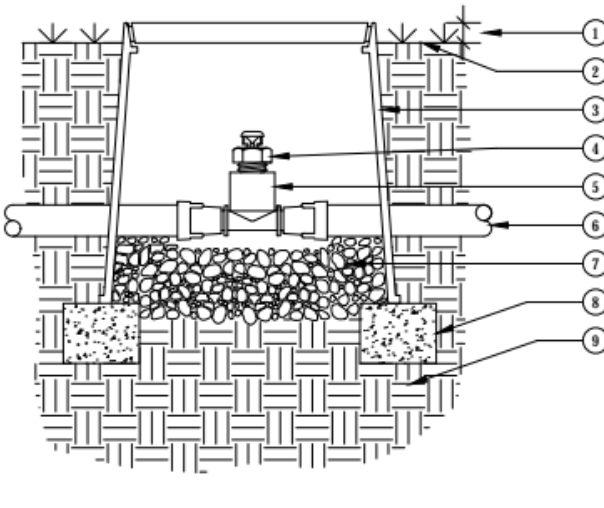

- 1" ABOVE FINISH GRADE.
  - FINISH GRADE.
  - 6" ROUND PLASTIC VALVE BOX. HEAT BRAND "AR" ON LID IN 1" HIGH CHARACTERS.
  - TORO DL2000 AIR/VACUUM RELIEF VALVE (YD-500-34).
  - TORO LOC-EZE X 1/2" FPT TEE (FTT16).
  - TORO DL2000 TUBING (RGP-XXX-XXX) OR TORO BLUE STRIPE POLY TUBING (EHD1645-XXX) AIR-RELIEF LATERAL.
  - PEA GRAVEL SUMP (6" DEEP).
  - BRICK SUPPORTS (2 COMMON BRICKS REQUIRED).
  - NATIVE SOIL PER SPECIFICATIONS.
- NOTE:  
USE ONE AIR/RELIEF VALVE FOR EVERY 7 GPM PER ZONE. LOCATE AT HIGH POINTS. REFER TO TORO PUBLICATION #ALT111 FOR SPECIFICATIONS.

**26 AIR/VACUUM RELIEF VALVE**  
NTS

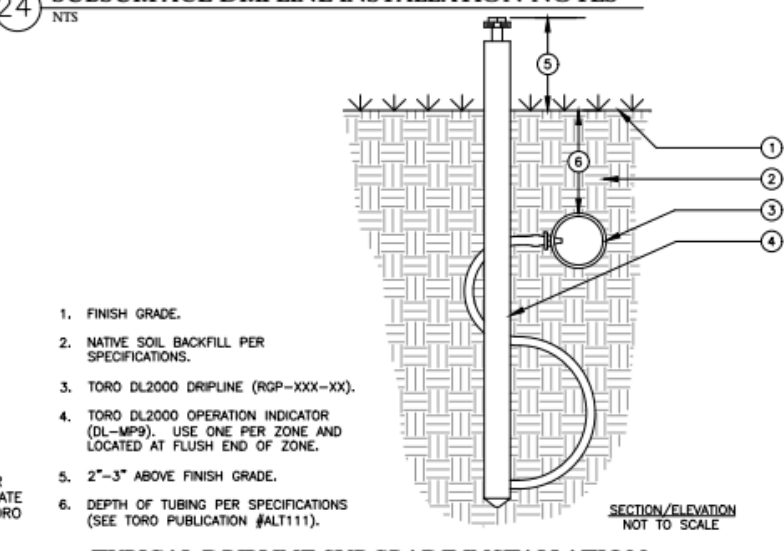

- FINISH GRADE.
- NATIVE SOIL BACKFILL PER SPECIFICATIONS.
- TORO DL2000 DRIPLINE (RGP-XXX-XX).
- TORO DL2000 OPERATION INDICATOR (DL-MP9). USE ONE PER ZONE AND LOCATED AT FLUSH END OF ZONE.
- 2"-3" ABOVE FINISH GRADE.
- DEPTH OF TUBING PER SPECIFICATIONS (SEE TORO PUBLICATION #ALT111).

**27 TYPICAL DRIPLINE SUBGRADE INSTALLATION**  
NTS

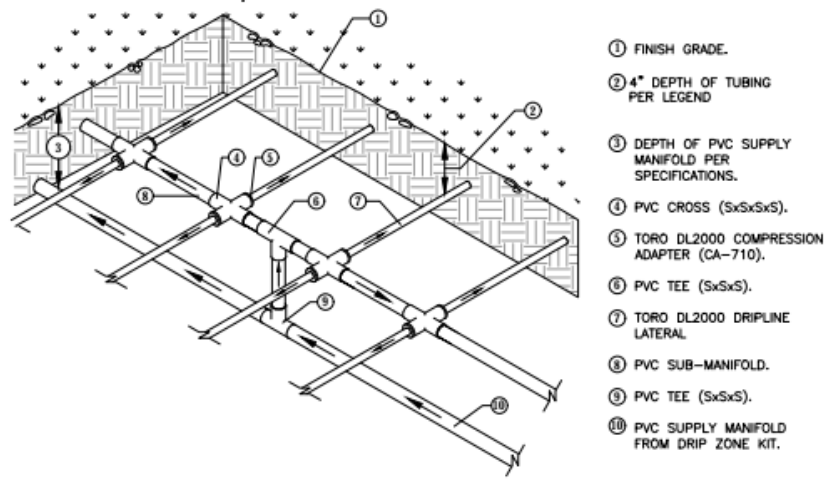

- ① FINISH GRADE.
- ② 4" DEPTH OF TUBING PER LEGEND
- ③ DEPTH OF PVC SUPPLY MANIFOLD PER SPECIFICATIONS.
- ④ PVC CROSS (SxSxT).
- ⑤ TORO DL2000 COMPRESSION ADAPTER (CA-710).
- ⑥ PVC TEE (SxSxS).
- ⑦ TORO DL2000 DRIPLINE LATERAL
- ⑧ PVC SUB-MANIFOLD.
- ⑨ PVC TEE (SxSxS).
- ⑩ PVC SUPPLY MANIFOLD FROM DRIP ZONE KIT.

28 DRIPLINE TO PVC INSTALLATION  
NTS

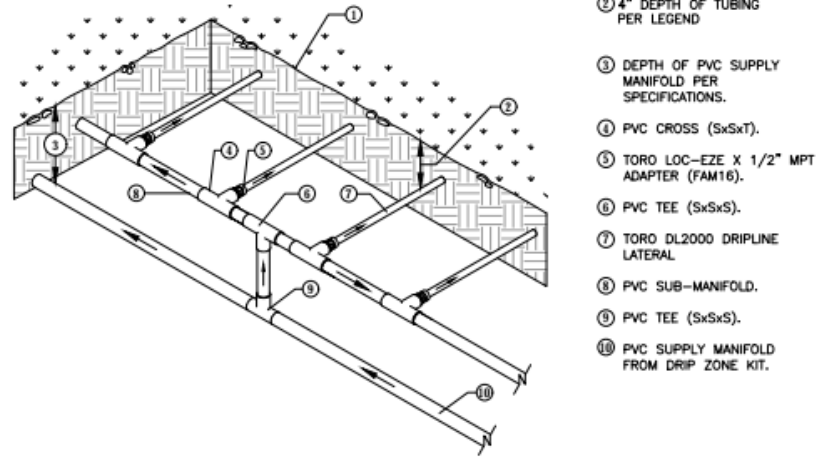

- ① FINISH GRADE.
- ② 4" DEPTH OF TUBING PER LEGEND
- ③ DEPTH OF PVC SUPPLY MANIFOLD PER SPECIFICATIONS.
- ④ PVC CROSS (SxSxT).
- ⑤ TORO LOC-EZE X 1/2" MPT ADAPTER (FAM16).
- ⑥ PVC TEE (SxSxS).
- ⑦ TORO DL2000 DRIPLINE LATERAL
- ⑧ PVC SUB-MANIFOLD.
- ⑨ PVC TEE (SxSxS).
- ⑩ PVC SUPPLY MANIFOLD FROM DRIP ZONE KIT.

29 DRIPLINE TO PVC INSTALLATION  
NTS

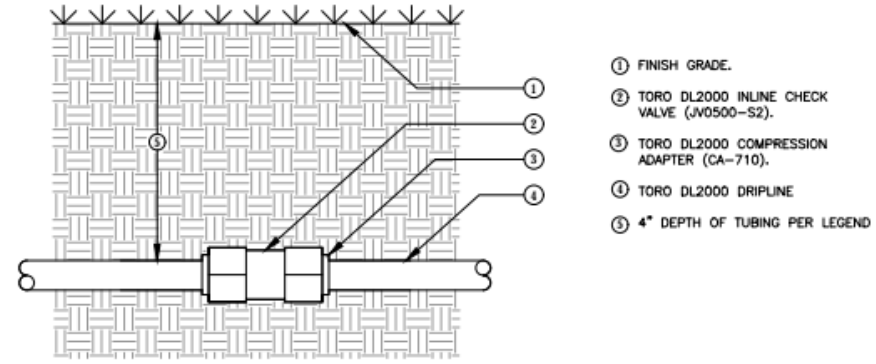

- ① FINISH GRADE.
- ② TORO DL2000 INLINE CHECK VALVE (JV0500-S2).
- ③ TORO DL2000 COMPRESSION ADAPTER (CA-710).
- ④ TORO DL2000 DRIPLINE
- ⑤ 4" DEPTH OF TUBING PER LEGEND

30 DRIPLINE TO INLINE CHECK VALVE DETAIL  
NTS

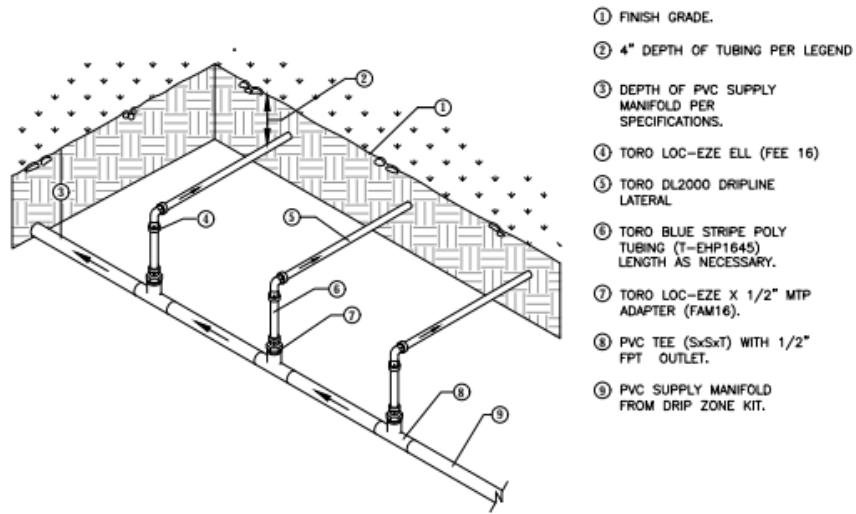

- ① FINISH GRADE.
- ② 4" DEPTH OF TUBING PER LEGEND
- ③ DEPTH OF PVC SUPPLY MANIFOLD PER SPECIFICATIONS.
- ④ TORO LOC-EZE ELL (FEE 16)
- ⑤ TORO DL2000 DRIPLINE LATERAL
- ⑥ TORO BLUE STRIPE POLY TUBING (T-EHP1645) LENGTH AS NECESSARY.
- ⑦ TORO LOC-EZE X 1/2" MPT ADAPTER (FAM16).
- ⑧ PVC TEE (SxSxT) WITH 1/2" FPT OUTLET.
- ⑨ PVC SUPPLY MANIFOLD FROM DRIP ZONE KIT.

31 DRIPLINE TO PVC HEADER INSTALLATION  
NTS

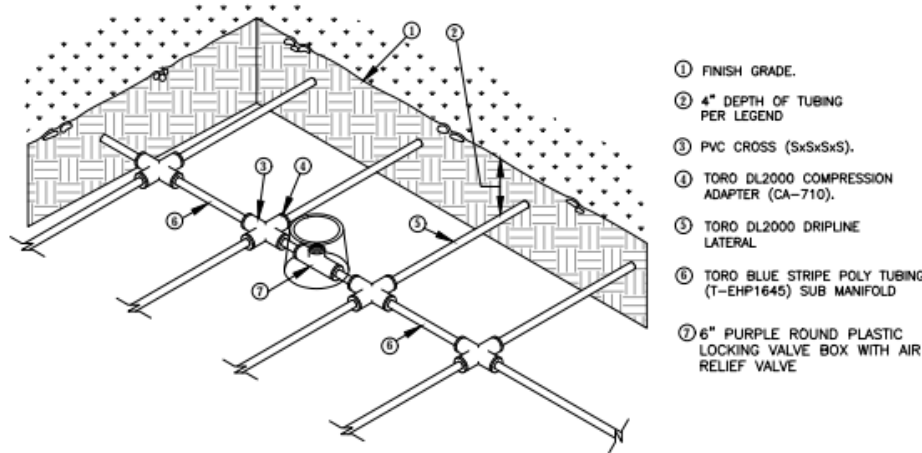

- ① FINISH GRADE.
- ② 4" DEPTH OF TUBING PER LEGEND
- ③ PVC CROSS (SxSxSxS).
- ④ TORO DL2000 COMPRESSION ADAPTER (CA-710).
- ⑤ TORO DL2000 DRIPLINE LATERAL
- ⑥ TORO BLUE STRIPE POLY TUBING (T-EHP1645) SUB MANIFOLD
- ⑦ 6" PURPLE ROUND PLASTIC LOCKING VALVE BOX WITH AIR RELIEF VALVE

32 AIR VACUUM RELIEF VALVE LOCATION  
NTS

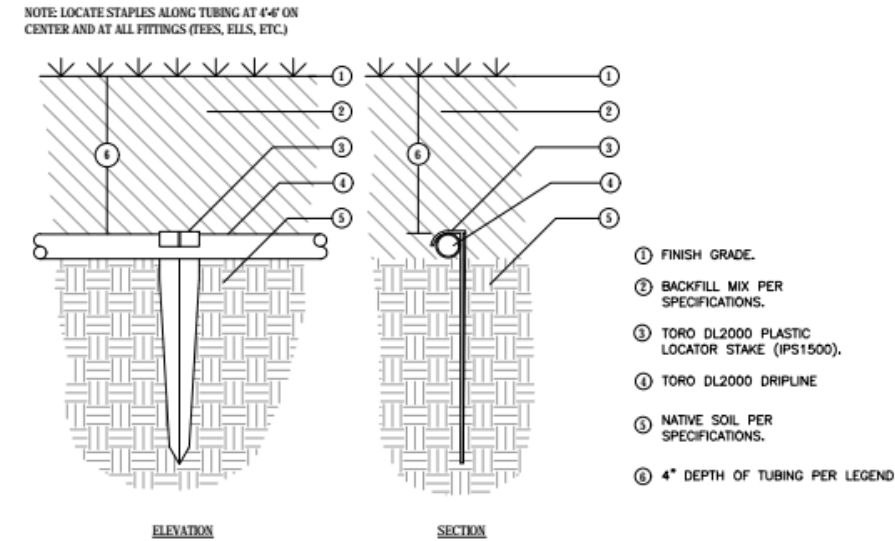

- ① FINISH GRADE.
- ② BACKFILL MIX PER SPECIFICATIONS.
- ③ TORO DL2000 PLASTIC LOCATOR STAKE (IPS1500).
- ④ TORO DL2000 DRIPLINE
- ⑤ NATIVE SOIL PER SPECIFICATIONS.
- ⑥ 4" DEPTH OF TUBING PER LEGEND

33 DRIPLINE STAKE BELOW GRADE DETAIL  
NTS

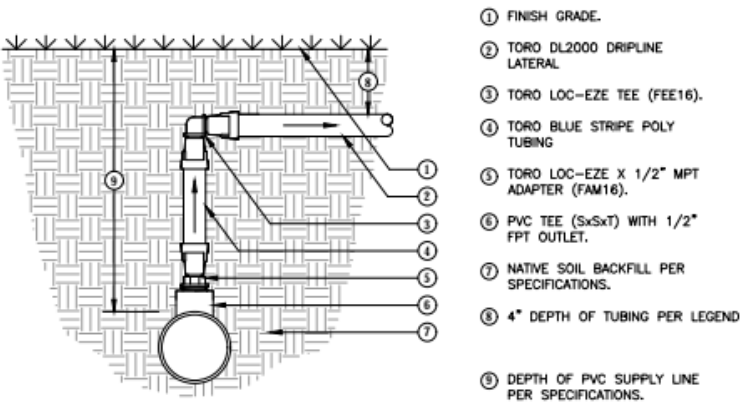

- ① FINISH GRADE.
- ② TORO DL2000 DRIPLINE LATERAL
- ③ TORO LOC-EZE TEE (FEE16).
- ④ TORO BLUE STRIPE POLY TUBING
- ⑤ TORO LOC-EZE X 1/2" MPT ADAPTER (FAM16).
- ⑥ PVC TEE (SxSxT) WITH 1/2" FPT OUTLET.
- ⑦ NATIVE SOIL BACKFILL PER SPECIFICATIONS.
- ⑧ 4" DEPTH OF TUBING PER LEGEND
- ⑨ DEPTH OF PVC SUPPLY LINE PER SPECIFICATIONS.

34 DRIPLINE TO PVC INSTALLATION  
NTS

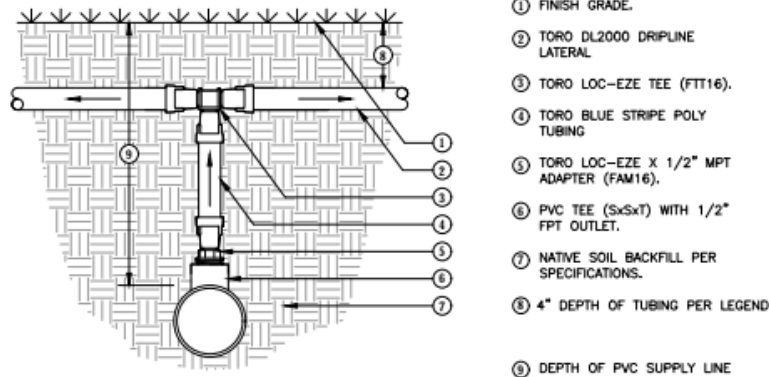

- ① FINISH GRADE.
- ② TORO DL2000 DRIPLINE LATERAL
- ③ TORO LOC-EZE TEE (FTT16).
- ④ TORO BLUE STRIPE POLY TUBING
- ⑤ TORO LOC-EZE X 1/2" MPT ADAPTER (FAM16).
- ⑥ PVC TEE (SxSxT) WITH 1/2" FPT OUTLET.
- ⑦ NATIVE SOIL BACKFILL PER SPECIFICATIONS.
- ⑧ 4" DEPTH OF TUBING PER LEGEND
- ⑨ DEPTH OF PVC SUPPLY LINE PER SPECIFICATIONS.

35 DRIPLINE TO PVC INSTALLATION  
NTS

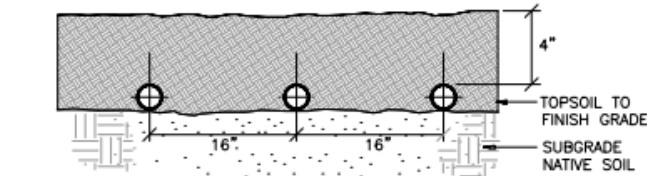

36 TYPICAL DRIPLINE SUBGRADE INSTALLATION  
NTS



**GATES + ASSOCIATES**  
LANDSCAPE ARCHITECTURE  
LAND PLANNING • URBAN DESIGN  
2671 CROW CANYON RD. SAN RAMON, CA 94583  
T 925.734.8176 www.gates.com

**DNS APARTMENTS**

HAYWARD  
CALIFORNIA

ISSUE	DESCRIPTION	DATE
ISSUE 1	PLAN REVIEW	04-21-16
ISSUE 2	2ND PLAN REVIEW	10-03-16
ISSUE 3	3RD PLAN REVIEW	01-19-17
ISSUE 4	4TH PLAN REVIEW	04-04-17
ISSUE 5	5TH PLAN REVIEW	06-30-17

**NOT FOR CONSTRUCTION**



PROJECT NUMBER:  
DRAWN: MM  
CHECK: MNO  
DATE: 04-04-17  
SCALE:



IRRIGATION DETAILS

**L3.6-A**

**FOR IRRIGATION AND WATER SERVICES  
WHERE REQUIRED BY CCR, TITLE 17, § 7604**

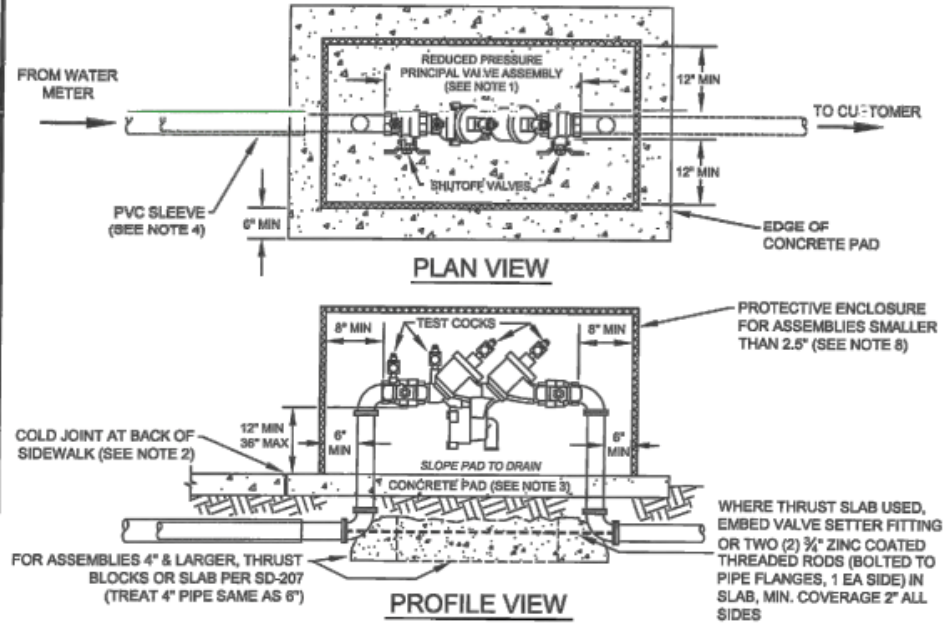

- NOTES:**
1. ALLOWED BACKFLOW ASSEMBLIES AND THEIR ORIENTATIONS SHALL BE LIMITED TO THOSE SPECIFIED ON THE 'LIST OF APPROVED BACKFLOW PREVENTION ASSEMBLIES,' BY THE UNIVERSITY OF SOUTHERN CALIFORNIA'S FOUNDATION FOR CROSS-CONNECTION CONTROL AND HYDRAULIC RESEARCH, 2010 OR LATEST REVISION.
  2. THE BACKFLOW DEVICE SHALL BE LOCATED: (A) A MAXIMUM OF 5' FROM BACK OF SIDEWALK (TYP.); (B) WHERE SCREENING IS REQUIRED, A MAXIMUM OF 30' FROM BACK OF SIDEWALK; OR (C) AT A LOCATION DETERMINED BY THE WATER DISTRIBUTION CROSS CONNECTION PERSONNEL IN THE FIELD.
  3. CONCRETE PAD SHALL BE CLASS B CONCRETE, 4\"/>

		<b>STANDARD - REDUCED PRESSURE PRINCIPAL BACKFLOW PREVEN- TION ASSEMBLIES</b>	DWG. NO. <b>SD-202</b>
DRAWN BY: RS CHECKED BY: AA APPROVED BY: [Signature]	DATE: 11/30/12 SCALE: NTS		FILED SHT. <b>1 OF 1</b>

Water calculation worksheet for the Model Water Efficient Landscape Ordinance AB 1881

Total Landscape Area (sf)	6,740	KL	Landscape Coefficient	Eto	Referenced Evapotranspiration Rate				
Special Landscape Area (SLA)	0	Ks	Species Factor	ETAF	ET Adjustment factor				
Historical Eto for project city	44.2	Kd	Density Factor	LA	Total Landscape area				
Turf Rotor Efficiency	0.75	Kmc	Microclimate Factor	0.62	Conversion factor to gallons				
Flood bubbler Irrigation Efficiency	0.81	IE	Irrigation Efficiency	SLA	Special Landscape Area				
Spray irrigation Efficiency	0.75								
Drip Irrigation Efficiency	0.81								
Stream Spray Efficiency	0.75								
		MAWA = (Eto)(0.62)(0.55 x LA + 0.45 x SLA)							
		ETWU = (Eto)(0.62)(PFxHA / IE) + SLA							
Maximum Applied Water Use (MAWA)									
	Eto	Conversion	ETAF	LA	(1-ETAF) SLA	Gallons per year			
Total landscape area	44.2	0.62	0.55	6,740	0.45	0	101,587		
<b>MAXIMUM APPLIED WATER ALLOWANCE</b>						<b>101,587</b>			
Estimated Total Water Use (ETWU)									
Hydrozone & Irrigation method	Area (sf)	Eto	Ks	Kd	Kmc	KL	IE	Conversion	Gallons per year
DNS Apartments	6,740	44.2	0.4	1	1	0.4	0.81	0.62	91,211
Total area	6,740								
<b>TOTAL WATER APPLIED</b>									<b>91,211</b>
Difference between MAWA & ETWU									10,375
% ETWU is under MAWA									10.2%



**GATES  
+ ASSOCIATES**

LANDSCAPE ARCHITECTURE  
LAND PLANNING • URBAN DESIGN

2671 CROW CANYON RD. SAN RAMON, CA 94583  
7 925.734.8176 www.gates.com

**DNS  
APARTMENTS**

HAYWARD  
CALIFORNIA

ISSUE	DESCRIPTION	DATE
ISSUE 1	PLAN REVIEW	04-21-16
ISSUE 2	2ND PLAN REVIEW	10-03-16
ISSUE 3	3RD PLAN REVIEW	01-19-17
ISSUE 4	4TH PLAN REVIEW	04-04-17
ISSUE 5	5TH PLAN REVIEW	06-30-17

**NOT FOR  
CONSTRUCTION**



PROJECT NUMBER:  
DRAWN: MM  
CHECK: MNO  
DATE: 04-04-17  
SCALE:



IRRIGATION DETAILS

**L3.7-A**

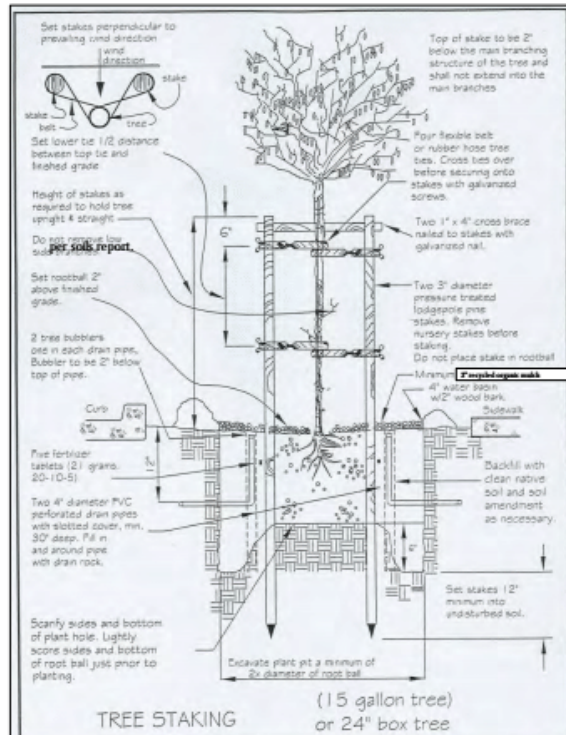

**CITY OF HAYWARD ENGINEERING DIVISION**

**STREET TREE PLANTING**

SD-122

9-25-02

1 2

**STREET TREE PLANTING SPECIFICATIONS**

- Tree shall be healthy, disease and insect-free, well rooted, and properly trained with a straight trunk that can stand upright without support. Tree shall exhibit a central leader, or a main branch that can be trained as a central leader. Branches shall be well-developed and shall be evenly and radially distributed around the trunk. Root ball shall not exhibit knicked or circling roots. After planting, no roots shall be left exposed.
  - Tree shall comply with federal and state laws requiring inspection for plant diseases and pest infestation. Clearance from the county agricultural commissioner, as required by law, shall be obtained before planting trees delivered from outside the county.
  - Prior to planting tree, determine the location of existing or future underground utilities. Locate tree a minimum of 5 feet from lateral service lines and driveways. Locate tree a minimum of 15 feet from a light pole, and a minimum of 30 feet from the face of a traffic signal, or as otherwise specified by the City.
  - Tree pit shall be tested for proper drainage prior to planting tree. Fill pit with water, if water remains after a 24-hour period, auger three 4" diameter by 3-foot deep holes at the bottom of the tree pit. Backfill with drain rock.
  - Set tree in an upright and plumb position. As much as possible, tree shall be positioned such that dominant branches are parallel to the roadway and are oriented away from potential conflicts.
  - If required by the City, a pressure-compensating bubbler, or drip emitters, shall be provided to each tree.
  - Depending on the planter strip width, or the tree well size and the tree species being planted, a 24" deep root-barrier may be required by the City to be placed between the root-ball and the curb and/or sidewalk. Length of strip barrier or size of the box barrier will be specified by the City.
- b. Stakes are to be removed when the tree diameter meets or exceeds the diameter of the stake.

**CITY OF HAYWARD ENGINEERING DIVISION**

**STREET TREE PLANTING**

SD-122

9-25-02

2 2

**7 STREET TREE PLANTING**  
1" = 1'-0"

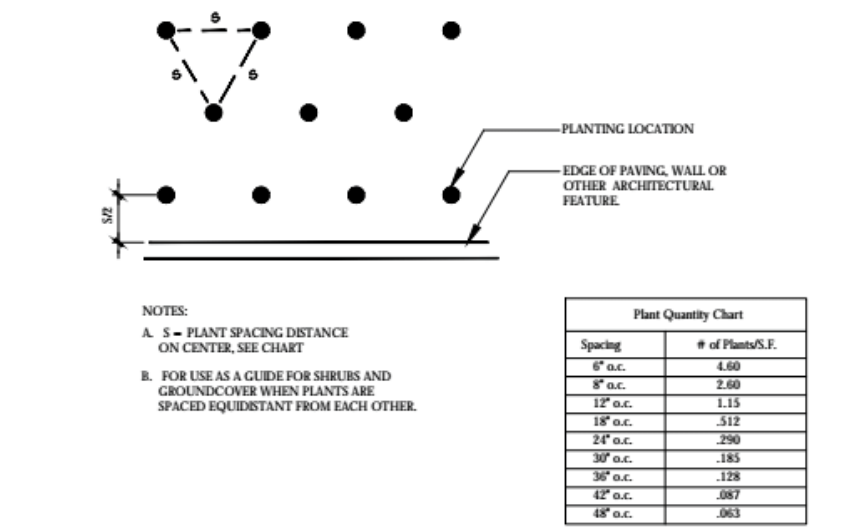

**6 PLANT SPACING**  
SCALE: N.T.S.

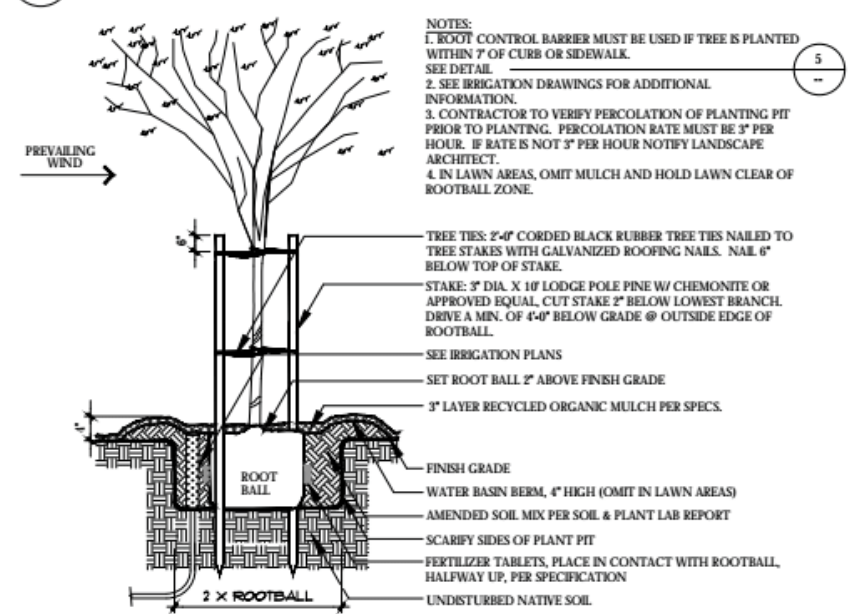

**5 TREE STAKING DETAIL - ON SITE**  
SCALE: 3/8" = 1'-0"

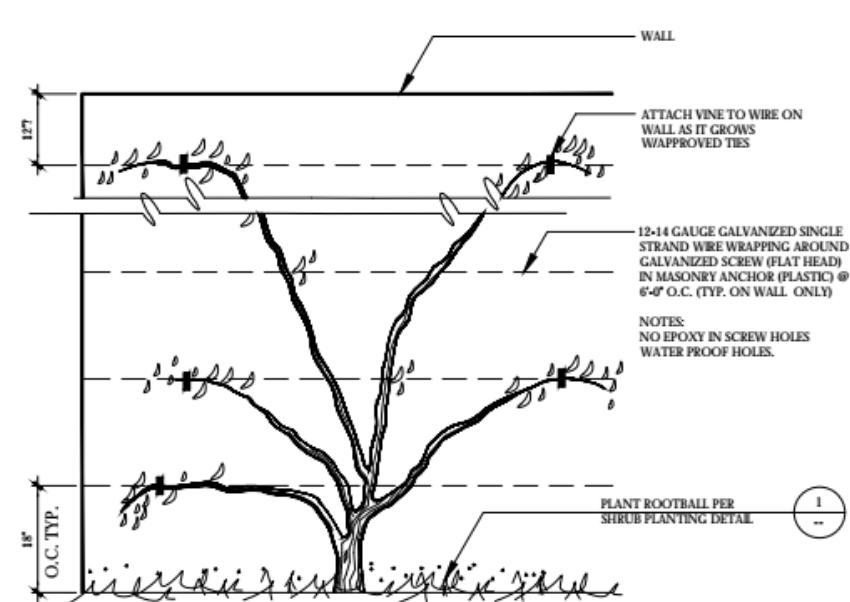

**4 VINE PLANTING**  
SCALE: N.T.S.

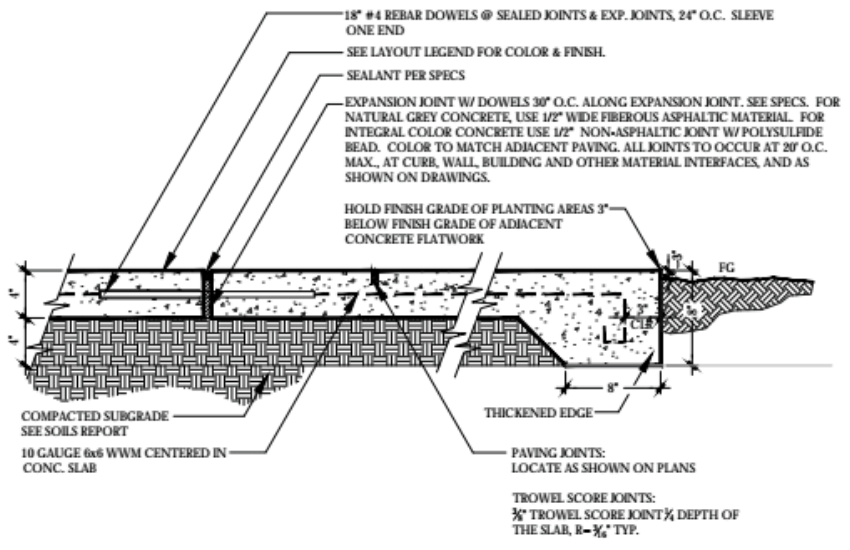

**3 PEDESTRIAN CONCRETE PAVING**  
SCALE: 1 1/2" = 1'-0"

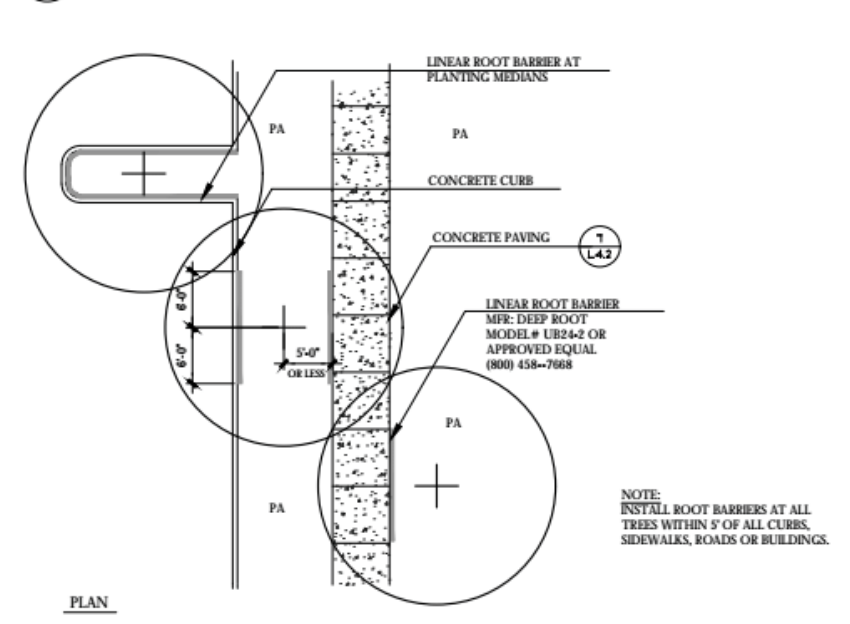

**2 LINEAR ROOT BARRIER**  
SCALE: 1" = 10'-0"

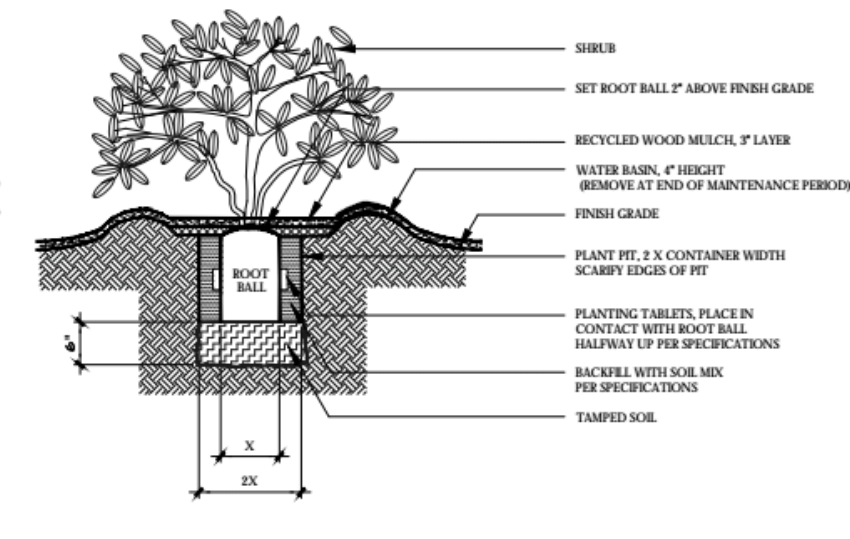

**1 SHRUB PLANTING**  
SCALE: N.T.S.



**GATES + ASSOCIATES**

LANDSCAPE ARCHITECTURE  
LAND PLANNING • URBAN DESIGN

2871 CROW CANYON RD., SAN RAMON, CA 94583  
7 925.734.4176 www.gates.com

**DNS APARTMENTS**

HAYWARD CALIFORNIA

ISSUE	DESCRIPTION	DATE
ISSUE 1	PLAN REVIEW	04-21-16
ISSUE 2	2ND PLAN REVIEW	10-03-16
ISSUE 3	3RD PLAN REVIEW	01-19-17
ISSUE 4	4TH PLAN REVIEW	04-04-17
ISSUE 5	5TH PLAN REVIEW	06-30-17

**NOT FOR CONSTRUCTION**



PROJECT NUMBER:

DRAWN: MM

CHECK: MNO

DATE: 04-04-17

SCALE:



CONSTRUCTION DETAILS

**L5.1-A**



# GATES + ASSOCIATES

LANDSCAPE ARCHITECTURE  
LAND PLANNING • URBAN DESIGN

2671 CROW CANYON RD. SAN RAMON, CA 94583  
T 925.736.8176 www.gates.com

## DNS APARTMENTS

HAYWARD CALIFORNIA

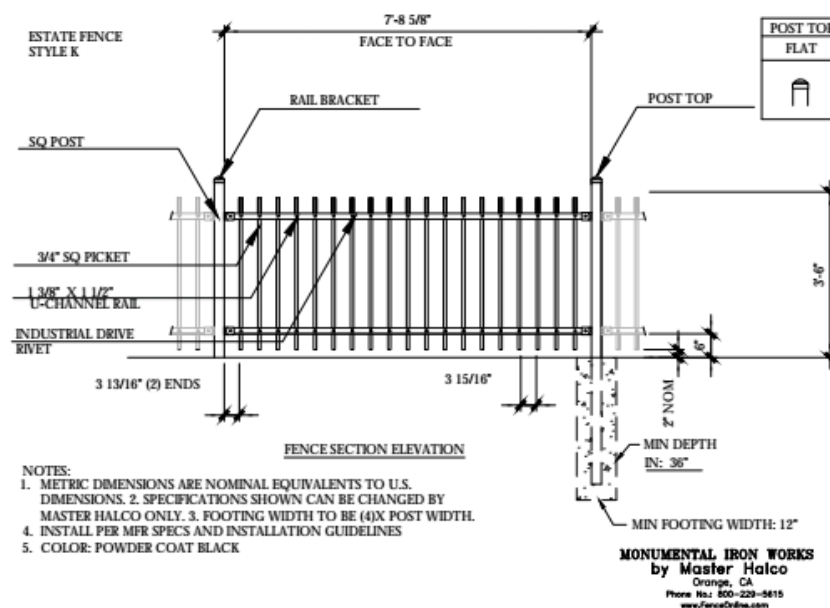

- NOTES:**  
1. METRIC DIMENSIONS ARE NOMINAL EQUIVALENTS TO U.S. DIMENSIONS. 2. SPECIFICATIONS SHOWN CAN BE CHANGED BY MASTER HALCO ONLY. 3. FOOTING WIDTH TO BE (4)x POST WIDTH. 4. INSTALL PER MFR SPECS AND INSTALLATION GUIDELINES. 5. COLOR: POWDER COAT BLACK.

**MONUMENTAL IRON WORKS**  
by Master Halco  
Orange, CA  
Phone No: 800-229-5815  
www.FenceOnline.com

**4 FENCE AT RETENTION BASIN**  
SCALE: 1/2" = 1'-0"

**Grasspave** porous pavement allows you to park, drive, walk, ride, or lounge on a beautiful grass surface. It performs the functions of asphalt or concrete pavement, but with the aesthetics of a lawn - all while enhancing the environment.

**Benefits:**

- Porous Load Bearing Surface
- Stormwater Pollution Filtration and Treatment
- Airborne Dust Capture and Retention
- Heat Energy Reduction Reduction, "Cool" Surfaces
- Tree Growth within Parking Areas
- 100% Real Grass Coverage
- 5,721 psi Compressive Strength
- Large Rolls for Easy Installation
- Competitive Advantages over other turf pavers.

**Applications:**

- Fire lanes
- Overflow, Stadium and Event Parking
- Church Parking
- Cross "Over" Driveway
- Utility Access
- On-street Parking - Grass Shoulders
- Pedestrian Walkways and "Cue Paths"
- Handicap Parking
- Emergency Access
- Vibration Basin Reinforcement
- Golf Cart Paths
- Erosion Control
- Helicopter Landing Pads
- Airplane Transport Areas
- See our project profiles for other uses.

**Grasspave** porous pavement is a structure which provides incredible load bearing strength while protecting vegetation root systems from deadly compaction. High void spaces within the entire cross-section enable excellent root development, and storage capacity for rainfall run storm events. For example, a 13 inch cross-section (one inch Grasspave<sup>2</sup> with sand and a 12 inch base course) can store 2.6 inches of water - 13 inches x approx. 20% void space). Stormwater is stored in movement through and across Grasspave<sup>2</sup> surfaces, which deposits suspended sediment and increases time to discharge. Suspended pollutants and moderate amounts of engine oils are consumed by active soil bacteria, which are aided by the system's excellent oxygen exchange capacity.

**Read the article "A Whole Lot of Turf" article.**

**Sizes:**  
Manufactured in 1 square meter units (3.2' x 3.2') or quarter-meter units (1.05' x 1.05' feet) and assembled into rolls. Please see our Roll Chart for dimensions. Some curves can be achieved without cutting.

**2 CMU WALL**  
SCALE: 1" = 1'-0"

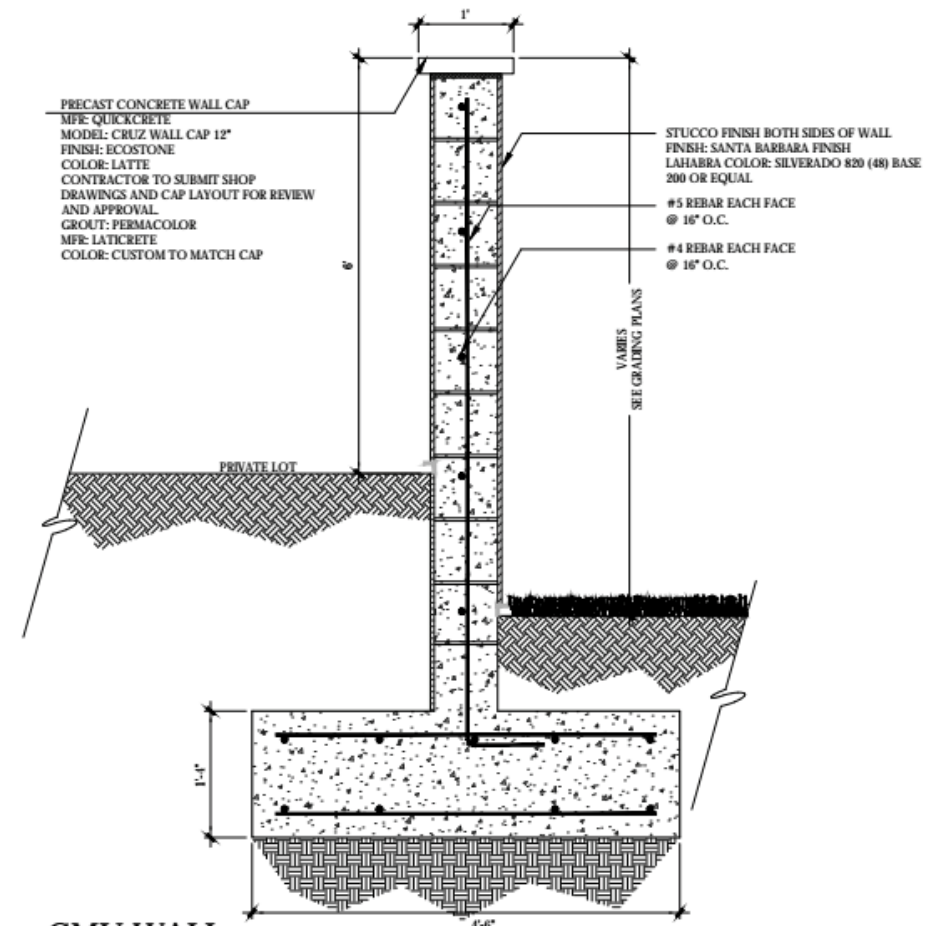

ISSUE	DESCRIPTION	DATE
ISSUE 1	PLAN REVIEW	04-21-16
ISSUE 2	2ND PLAN REVIEW	10-03-16
ISSUE 3	3RD PLAN REVIEW	01-19-17
ISSUE 4	4TH PLAN REVIEW	04-04-17
ISSUE 5	5TH PLAN REVIEW	06-30-17

**NOT FOR CONSTRUCTION**



PROJECT NUMBER:  
DRAWN: MM  
CHECK: MNO  
DATE: 04-04-17  
SCALE:



CONSTRUCTION DETAILS

# L5.2-A

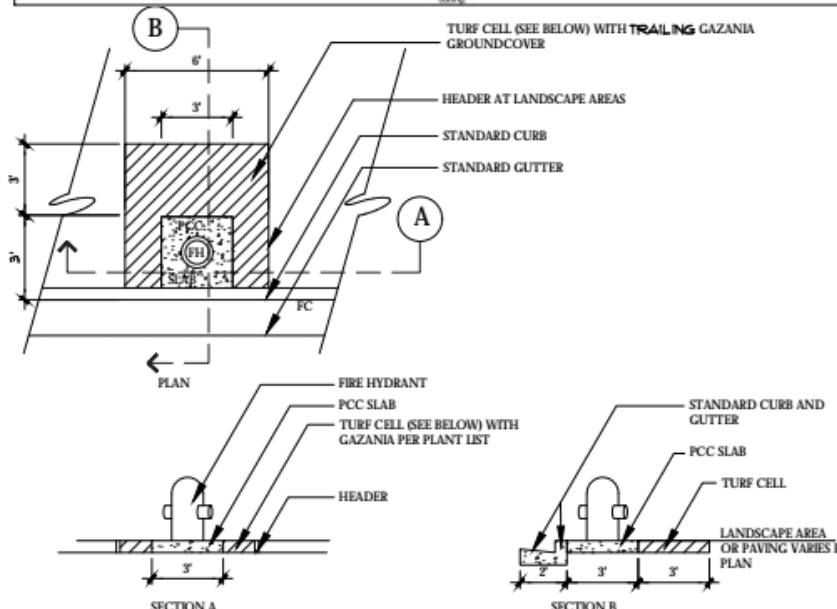

**3 FIRE HYDRANT PAD**  
SCALE: 1/4" = 1'-0"

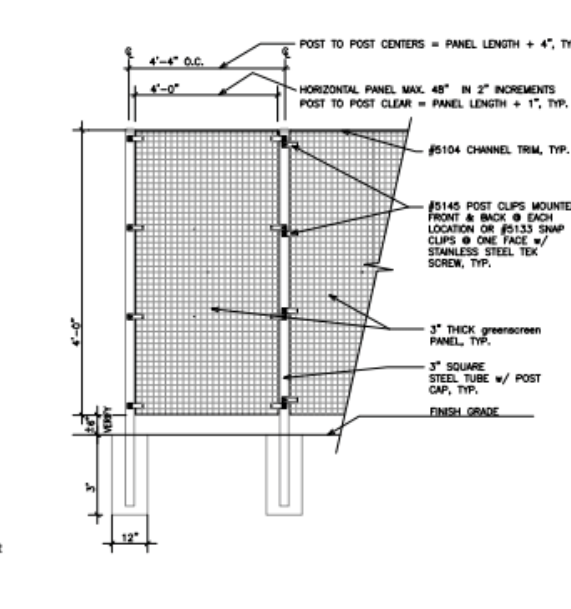

**1 GREENSCREEN FREESTANDING FENCE**  
SCALE: 3/8" = 1'-0"



MFR: GREENSCREEN 1(800)450.3494 OR APPROVED EQUAL  
COLOR: SILVER  
NOTE: 1. CONTRACTOR TO SUBMIT SHOP DRAWINGS AND FOOTING DETAILS FOR APPROVAL.  
2. INSTALL PER MFR'S SPECIFICATIONS



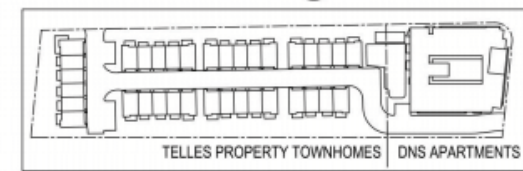
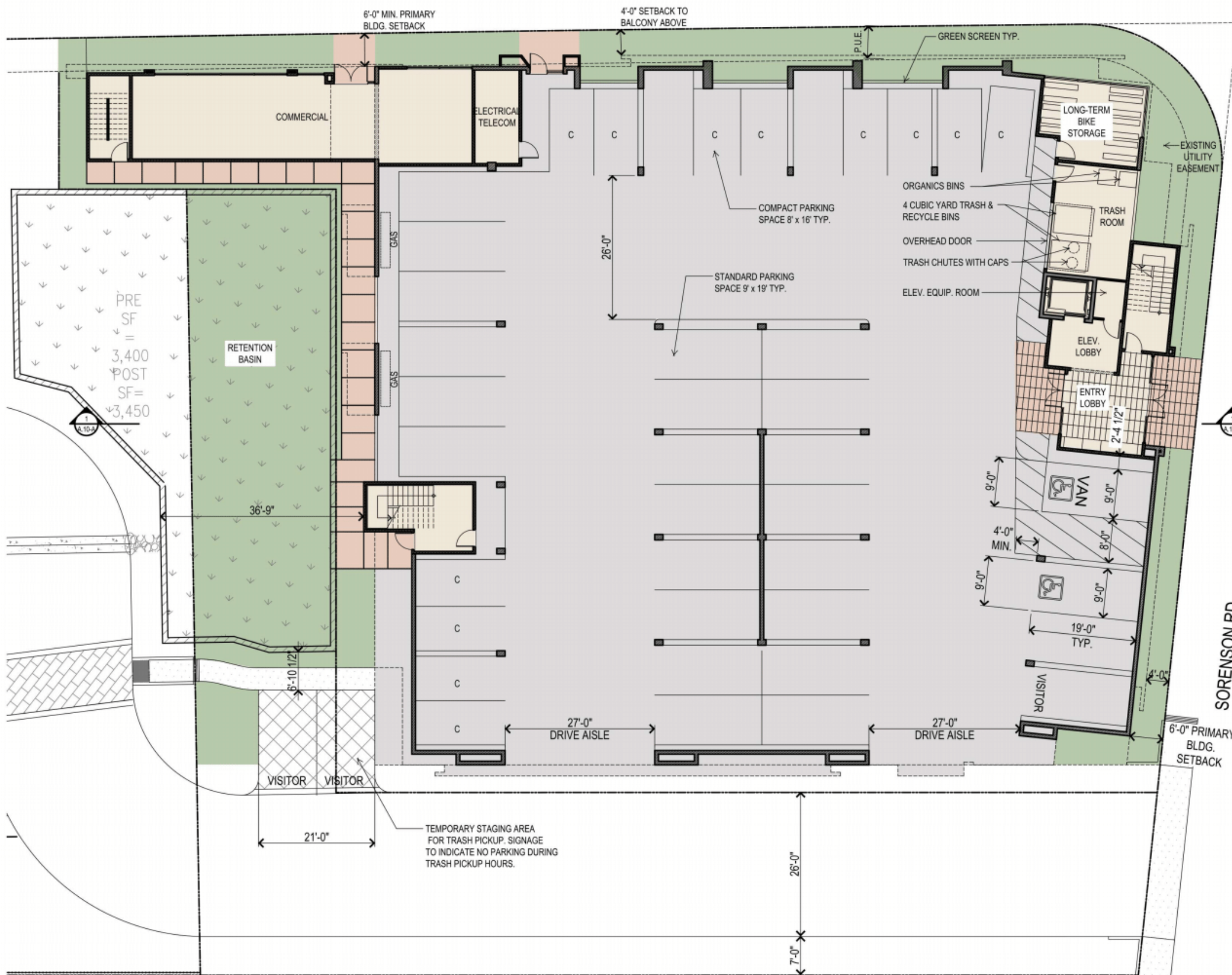

**SITE DATA:**  
 JURISDICTION: CITY OF HAYWARD  
 APN: 452-0036-30-50  
 ADDRESS: 26699 MISSION BLVD.  
 HAYWARD, CA. 94544  
 (INTERSECTION OF MISSION & SORENSON)

**PROJECT DESCRIPTION:**  
 A TOTAL OF 39 APARTMENTS (1&2 BEDROOM) ABOVE A PARKING GARAGE WITH AN ATTACHED COMMERCIAL STOREFRONT SPACE.

**BUILDING INFORMATION:**

UNIT MIX:		
1BR - "UNIT 1A"	(692 SF)	9
1BR - "UNIT 1B"	(779 SF)	3
1BR - "UNIT 1C"	(655 SF)	3
1BR - "UNIT 1D"	(785 SF)	3
2BR - "UNIT 2"	(1012 SF)	21
<b>TOTAL UNITS</b>		<b>39</b>

APARTMENTS:	39
COMBINED W/ ADJ. TOWNHOME PROJECT (74 DU/2.14 ACRES):	34.6 DU/AC
BY RIGHT MAXIMUM DENSITY:	35 DU/AC
NUMBER OF STORIES / HEIGHT:	4 STORIES / APPROX. 52'-0"
<b>AREA:</b>	
LIVING:	34,220 SF
PRIVATE DECKS:	2,615 SF
CIRCULATION:	9,100 SF
INDOOR COMMON SPACE:	2,072 SF
OUTDOOR COMMON SPACE:	4,628 SF
UTILITY:	431 SF
REMOTE RESIDENT STORAGE:	744 SF
COMMERCIAL:	1,020 SF
PARKING:	14,928 SF
<b>TOTAL:</b>	<b>69,758 SF</b>

**OCCUPANCY GROUPS:**  
 R-2 (APARTMENTS)  
 U & OR S (GARAGE/STORAGE)  
 ASSEMBLY (GYM/COMMUNITY ROOM)  
 B (BUSINESS)

**CONSTRUCTION TYPE:** TYPE V-A SPRINKLERED

**PARKING ANALYSIS:**  
 MIN. PARKING REQUIRED: NONE  
 MAX. PARKING ALLOWED: 69 SPACES  
 RESIDENCES (39 x 1.75)

**PARKING PROVIDED:**  
 RESIDENT (COVERED): 39 SPACES  
 VISITOR (1 COVERED, 2 UN-COVERED): 3 SPACES  
 ON-SITE TOTAL: 42 SPACES (1 ADA, 1 VAN ACCESSIBLE)

COMPACT TO STANDARD SPACE RATIO: (12 / 43) 28%  
 STANDARD SPACE DIMENSIONS: 9' x 19'  
 COMPACT SPACE DIMENSIONS: 8' x 15'

**BICYCLE PARKING ANALYSIS:**  
 MIN. SHORT TERM PARKING REQUIRED: 0.05 x 60 BEDROOMS PROVIDED 3 SPACES  
 PROVIDED: 3 SPACES  
 MIN. LONG TERM PARKING: 0.15 x 60 BEDROOMS REQUIRED 9 SPACES  
 PROVIDED: 12 SPACES





**DNS APARTMENTS**  
Hayward, CA  
July 26, 2017

DNS CAPITAL PARTNERS, LLC.  
1350 Treat Blvd., Suite 400  
Walnut Creek, CA. 94597

**ELEVATIONS**  
A.2-A

3361 Walnut Blvd. Suite 120 Brentwood, CA 94513  
925.634.7000  
www.straussdesign.com





WEST ELEVATION



NORTH ELEVATION

TYPICAL EXTERIOR MATERIALS

- ① - EXTERIOR PLASTER, LIGHT SAND FINISH
- ② - BOARD & BATTEN VERTICAL SIDING
- ③ - PERFORATED MESH METAL RAILINGS
- ④ - "GREEN SCREEN" WOVEN WIRE MESH AT GARAGE OPENINGS
- ⑤ - FIXED SPANDREL GLASS
- ⑥ - TRANSLUCENT LIGHT-TRANSMITTING OBSCURE GLASS @ BIKE ROOM
- ⑦ - STEEL PLANTER FOR GREEN SCREEN
- ⑧ - METAL ROOF
- ⑨ - RADIO - TRANSPARENT ENCLOSURE FOR CELLULAR EQUIPMENT



DNS APARTMENTS  
Hayward, CA  
July 26, 2017

DNS CAPITAL PARTNERS, LLC.  
1350 Treat Blvd., Suite 400  
Walnut Creek, CA. 94597

ELEVATIONS  
A.3-A

3361 Walnut Blvd. Suite 120 Brentwood, CA 94513  
925.634.7000  
www.straussdesign.com



SDG Architects, Inc.

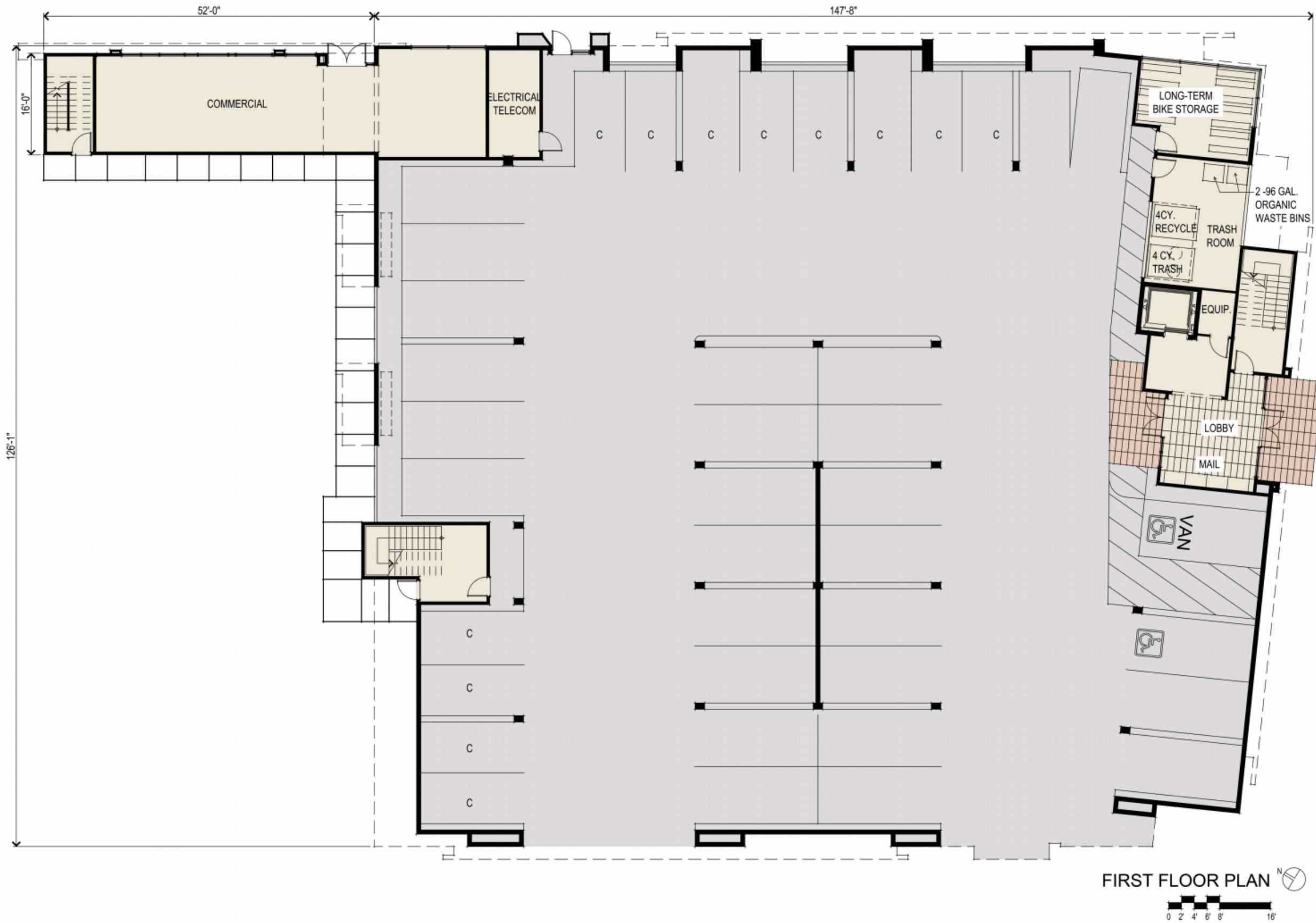

FIRST FLOOR PLAN

DNS APARTMENTS

Hayward, CA  
July 26, 2017

DNS CAPITAL PARTNERS, LLC.  
1350 Treat Blvd., Suite 400  
Walnut Creek, CA. 94597

FIRST FLOOR PLAN

A.4-A

3361 Walnut Blvd. Suite 120 Brentwood, CA 94513  
925.634.7000  
www.strausdesign.com



SDG Architects, Inc.



SECOND FLOOR PLAN   
 0 2 4 6 8 16'

DNS APARTMENTS  
 Hayward, CA  
 July 26, 2017

DNS CAPITAL PARTNERS, LLC.  
 1350 Treat Blvd., Suite 400  
 Walnut Creek, CA. 94597

SECOND FLOOR PLAN  
 A.5-A

3361 Walnut Blvd. Suite 120 Brentwood, CA 94513  
 925.634.7000  
 www.strausdesign.com





THIRD FLOOR PLAN

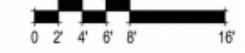

DNS APARTMENTS

Hayward, CA  
July 26, 2017

DNS CAPITAL PARTNERS, LLC.  
1350 Treat Blvd., Suite 400  
Walnut Creek, CA. 94597

THIRD FLOOR PLAN

A.6-A

3361 Walnut Blvd. Suite 120 Brentwood, CA 94513  
925.634.7000  
www.strausdesign.com



SDG Architects, Inc.



FOURTH FLOOR PLAN   
 0 2 4 6 8 16'

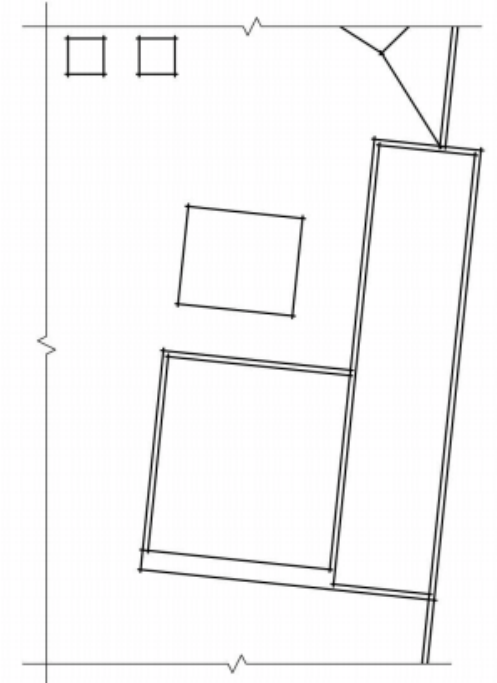
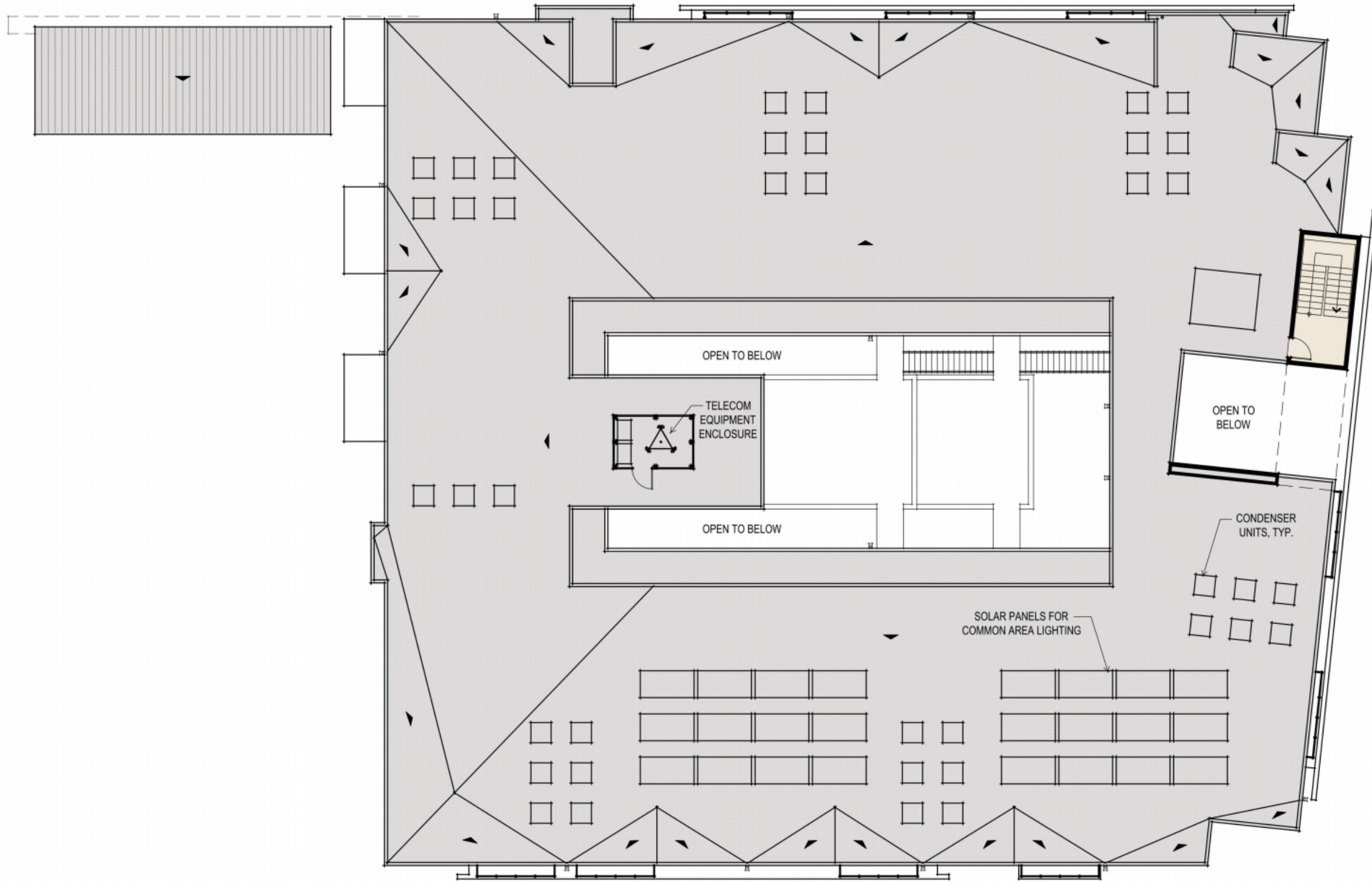

PARTIAL ROOF PLAN

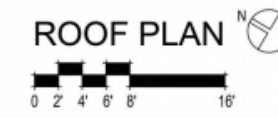





UNIT 1A

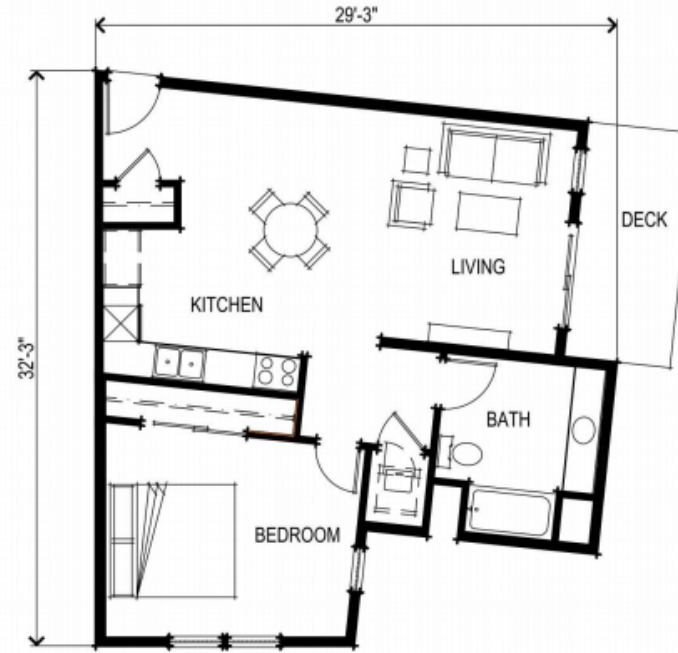

UNIT 1B

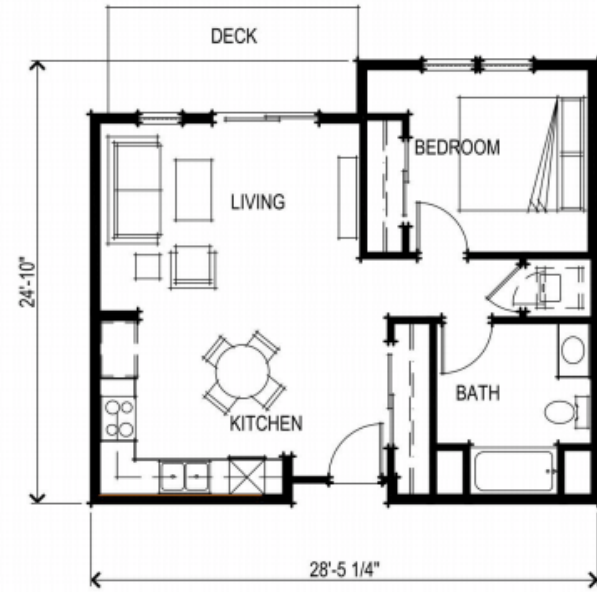

UNIT 1C

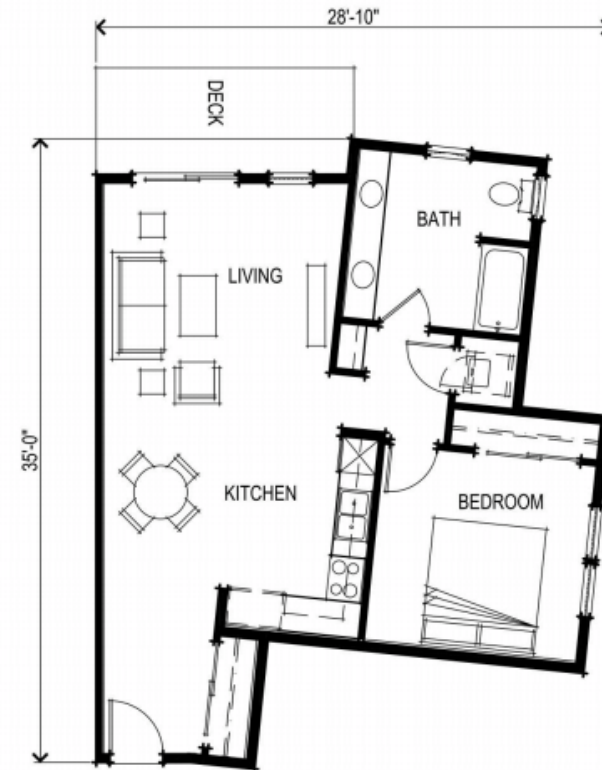

UNIT 1D



UNIT 2



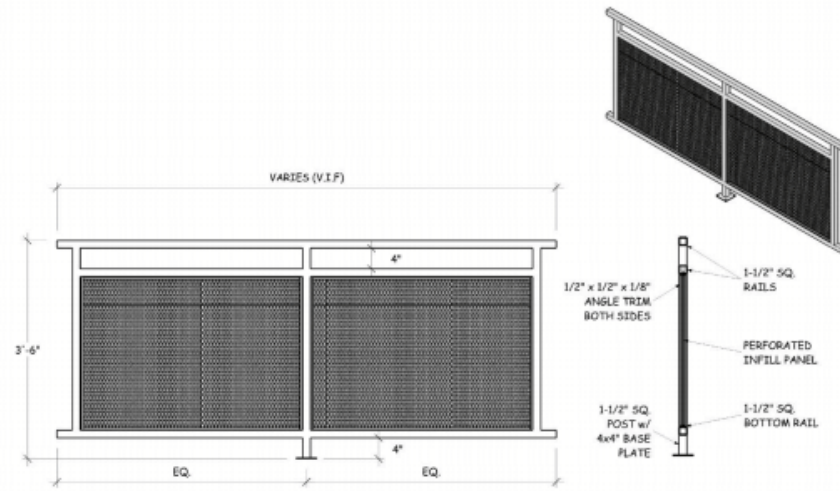

TYPICAL EXTERIOR  
③ CORRIDOR & BALCONY RAILING



STEEL HANDRAIL  
PRECAST TREADS & RISERS  
ON STEEL STRINGERS

② TYPICAL COMMON SPACE STAIR

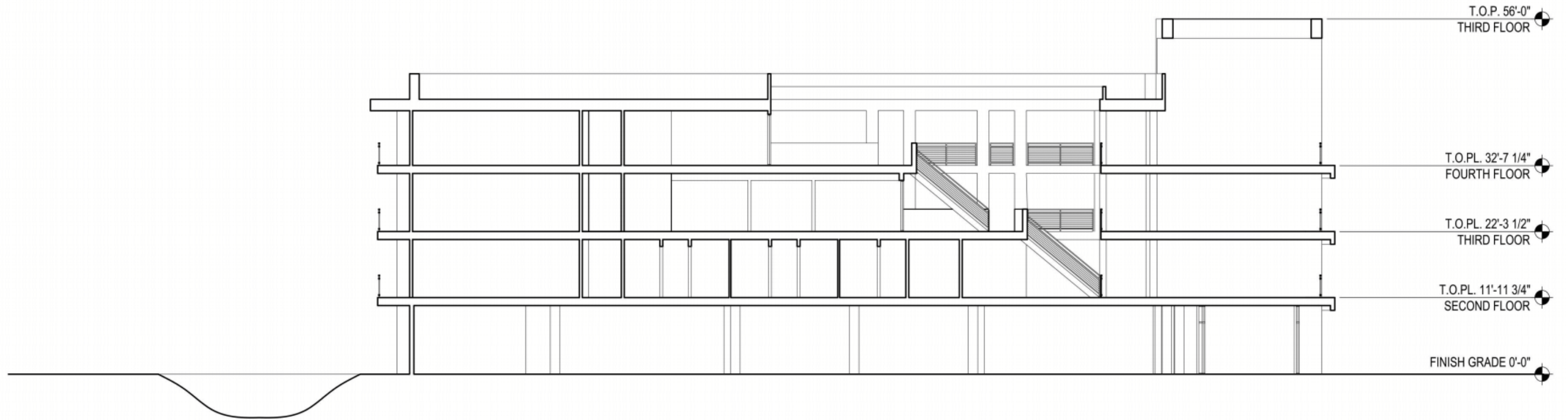

① BUILDING SECTION



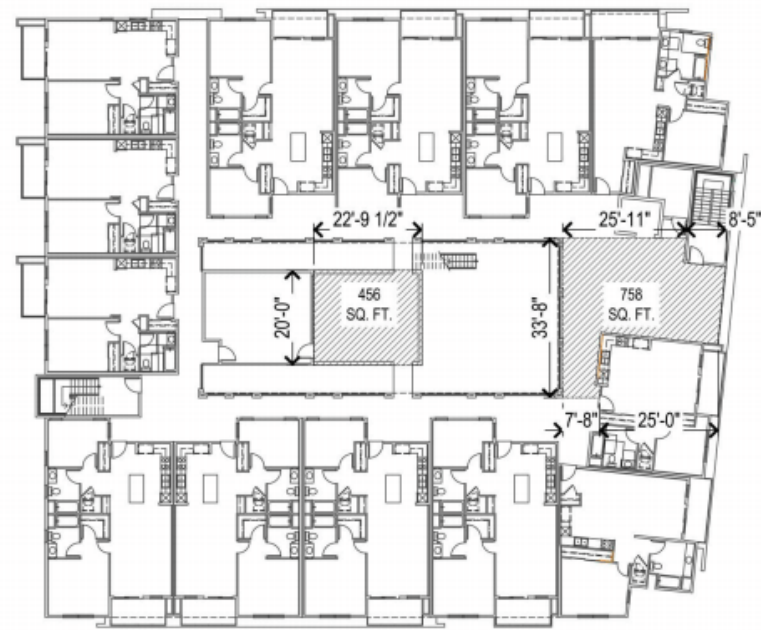

FOURTH FLOOR PLAN   

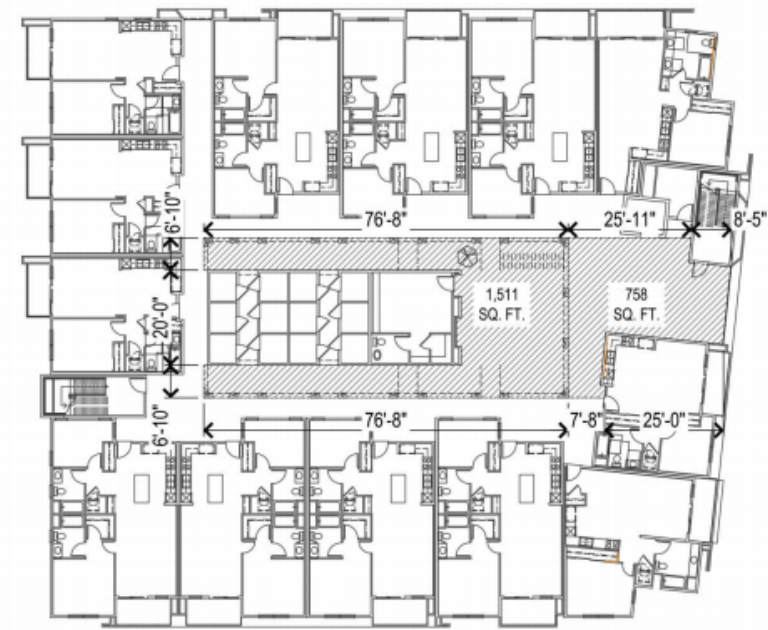

THIRD FLOOR PLAN   

SECOND FLOOR PLAN   

COMMON OPEN SPACE PROVIDED		
SECOND FLOOR	758+1,511	= 2,269
THIRD FLOOR	758+387	= 1,145
FOURTH FLOOR	758+456	= 1,214
		4,628 SQ. F.T.

REQUIRED 30,853 x .15 = 4,628 SQ. F.T.

DNS APARTMENTS  
 Hayward, CA  
 July 26, 2017

DNS CAPITAL PARTNERS, LLC.  
 1350 Treat Blvd., Suite 400  
 Walnut Creek, CA. 94597

COMMON OPEN SPACE EXHIBIT  
 A.11-A

3361 Walnut Blvd. Suite 120 Brentwood, CA 94513  
 925.634.7000  
 www.strausdesign.com



	EXTERIOR PLASTER 1 SW 7641 Colonade Gray
	EXTERIOR PLASTER 2 SW 7551 Greek Villa
	EXTERIOR PLASTER 3 SW 9163 Tin Lizzie
	BOARD & BATTEN VERTICAL SIDING SW 7603 Poolhouse
	FIXED SPANDREL GLASS SW 6764 Swimming
	METAL ACCENT SW 2848 Roycroft Pewter

*Note: All colors and textures are representative samples only, pending verification of actual material suppliers and manufacturers for this particular project.*